

FITTING INSTRUCTIONS AND PARTS LIST

SBV Sunflower Extension

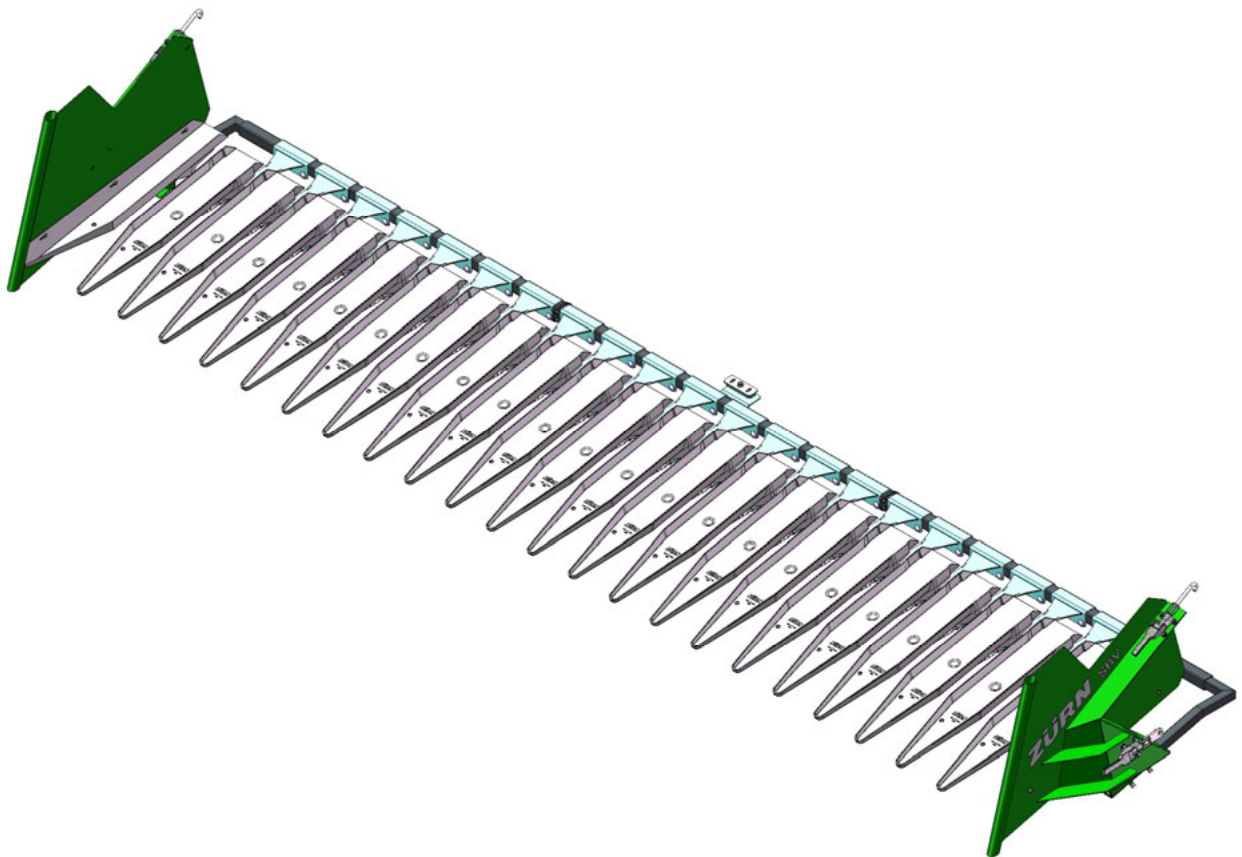

For John Deere / Zürn series 600PF
cutting platforms

Masthead

Title: Fitting instructions and parts list sunflower extensions
Manufacturer: Zürn Harvesting GmbH & Co. KG
Schöntal
Applicable to: SBV for cutting platforms 600PF
Print number: 41047

^{1st} issue 2023 (Version C)

Editorial date 08/2023

© Zürn Harvesting GmbH & Co. KG

Author: Naiome Köllisch

All rights reserved, also applies to the translation.

No part of this operating manual must be reproduced in any form (print, photocopy or any other process) or processed, duplicated or distributed using electronic systems without the written permission of the Zürn Harvesting GmbH & Co. KG, Schöntal.

We reserve the right to make technical amendments.

Printed on paper made from chlorine-free and acid-free bleached pulp.

Foreword

This machine is designed only for the usual application in agricultural work or similar activities. Any other use beyond this is deemed improper use of the machine. The manufacturer accepts no liability whatsoever for damage resulting from improper use; the risk will be borne solely by the user. Proper use also includes complying with the operation, maintenance and service conditions specified by the manufacturer.

Read this operating manual thoroughly to familiarise yourself with the correct operation and maintenance of the machine and to prevent injuries or damage to the machine. Not doing so can result in injuries or machine damage. This operating manual and the safety labels on the machine may also be available in other languages: please enquire at your dealership.

This operating manual is part of the machine and should be handed over to the purchaser if the machine is re-sold.

Dimensions specified in this operating manual are metric. Use only appropriate parts and bolts. Different spanners are required for metric bolts and bolts with imperial (inch) dimensions.

The designations "left" and "right" are with reference to the forward direction of the machine.

Enter the serial number in the first section of the operating manual. Please record all numbers accurately. In case of theft, these numbers can be important for tracing the machine. Your dealer also needs these numbers when you order spare parts. It is a good idea to keep a second record of these numbers in another location.

Your dealer has carried out an inspection of the machine prior to delivery. A further inspection should be carried out by your dealer after the first 20 to 50 hours of operation in order to ensure the best possible performance for the machine.

This machine must only be used, serviced and repaired by persons who are familiar with it and who have been briefed about its hazards. The relevant accident prevention regulations and other generally recognized rules and laws for safety, occupational health and road traffic must also be observed. Unauthorized changes to this trailer release the manufacturer from liability for any resulting damage.

Contents

Masthead	2
Foreword	3
Contents	4
Type Plates	6
Safety Instructions	7
Safety instructions for technical staff and operators	8
Hydraulic system	9
Universal drive shafts	10
Ejection of stones and foreign objects	11
Precautions for use and shunting	12
Precautions for maintenance and repair work	12
Precautions for travelling on public roads	13
Modifications to the machine	14
Welding	14
Bolted assemblies	14
Using original parts	15
Waste prevention	15
Safety decals	16
Important information	19
Assembly instructions	20
Assembling the supporting bars	20
Assembling the supporting bars	21
Attaching the side plates	22
Preparing the header for attaching the sunflower extension	23
Attaching the sunflower extension to the header	25
Fitting the pan holders	26
Installing the central support	27
Installing the central support	28
Mounting the central pans	29
Attaching the outboard pans and aligning the side plates	34
Attaching the side plates and the supporting arms	39
Installing the reel boards	40
Installing the central support	42
Attachment and removal of the assembled sunflower extension	43
Removing the extension from the header	43
Attaching the extension to the header	43
Parts list	44
Right side plates	44
Left side plates	45
Supporting arms and bars	46
Supporting bars	48
Reel boards	50
Central pan	52
Outboard pans left hand and right hand	53

Accessories – Premium Flow 600	54
Accessories - central support.....	55
Accessories - bracket.....	56
Accessories - reel support set.....	57
Torques for Metric Bolts	58
General terms of guarantee	59
EG- Konformitätserklärung	61
Contacts	62

Type Plates

Please make a note of the type designation and serial number of your machine here. This information must be given to the authorised dealer when ordering spare parts or making guarantee enquiries.

Type: _____

Serial number: _____



Safety Instructions

Explaining the symbols used in this document

This symbol indicates a potentially hazardous situation which, if not avoided, may lead to personal injury.



This symbol indicates special rules or procedures that need to be observed to avoid machine damage.



This symbol indicates special technical instructions.



The illustrations in this manual are used as examples and may differ from the product. All information and data are subject to change by the manufacturer alone without prior notice.

Safety Instructions

Safety instructions for technical staff and operators

Before using the machine, carefully read and observe all safety rules listed in this manual and observe all decals on the machine.

Before starting work, make sure that you are familiar with all mechanisms and controls and their functions. During operation is too late!

Never leave the machine to anyone who has not been trained in using and operating it properly.

Contact your Zürn sales partner if you have problems understanding certain parts of this manual.



Always apply the handbrake on the header transporter and shut off the engine of the towing vehicle before you work on the transporter. Remove the ignition key and wait until all moving parts have come to a complete stop.

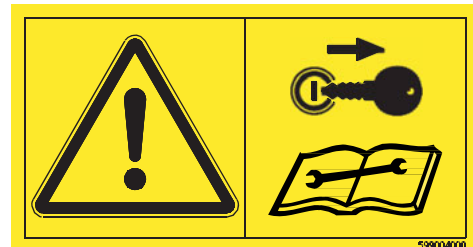

Wear close-fitting clothes! Loose clothing can easily get caught in moving machine parts.

Wear protective gear that suits the work at hand (gloves, footwear, goggles, helmet, ear protectors, etc.).

Any ropes, cables, linkages, etc. of remote-controlled mechanisms must be routed and installed in such a way that they do not cause unintentional machine action leading to accidents and damage. This applies to all transport and working positions.

Before each use verify that nuts and bolts are tight - especially those that attach tools such as blades. Retighten if necessary.

Before you use the machine make sure all safety features and guards are in place, in protective position and operable. Immediately replace any inoperable safety features.



Safety Instructions

Hydraulic system

Attention! The hydraulic system is under high pressure. Maximum operating pressure: 200 bar (2900 psi).

Before connecting hydraulic hoses to the hydraulic system of the machine, make certain that it is not pressurised. Before disconnecting hydraulic hoses, depressurise the hydraulic system.

In order to prevent connecting the hydraulic hoses to the wrong connections, colour code the hoses and their respective connections without fail. Risk of injury through reverse function because of reversed connections (e.g. raising instead of lowering).

Inspect the hydraulic hoses at regular intervals. Hydraulic hoses must always be replaced after 5 years at the latest. If hydraulic hoses are found to be damaged or worn, they must be replaced immediately. The replacement hydraulic hoses must comply with the technical requirements specified by the manufacturer.

Only use the appropriate resources when looking for leakages. Protect body and hands against pressurised fluids.

Oil escaping under pressure can puncture the skin and cause severe injuries. In the event of injury, seek medical attention immediately. There is a risk of infection.

Before carrying out any work on the hydraulic system, lower the machine to the ground, depressurise the hydraulic system, switch the engine OFF, remove the ignition key and wait until all moving parts have come to a complete standstill.

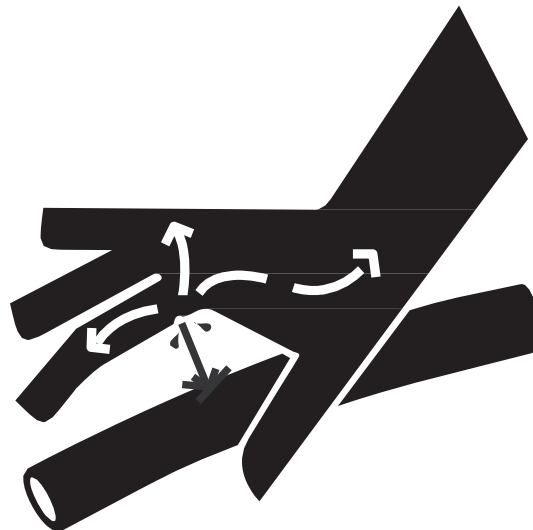

Safety Instructions

Universal drive shafts

Only use universal drive shafts that have been provided by or prescribed by the manufacturer.

The protective tube and protective cone on the PTO shaft and all PTO shaft protective devices on the header must be in place and in good condition.

Worn or damaged protective parts must be renewed immediately. Defective protective parts or an unprotected universal drive shaft can cause severe or even fatal injuries.

Always wear close-fitting clothing to prevent being caught up in a rotating universal drive shaft.

Before connecting or disconnecting a universal drive shaft and before any intervention in the header, uncouple the main drive, switch the engine OFF, remove the ignition key and wait until all moving parts have come to a complete standstill.

When using universal drive shafts with and overload or free-wheel clutch, always connect the overload or free-wheel clutch to the machine.

Always make certain that the universal drive shaft is connected and latched in position correctly.

Before switching the PTO shaft ON, make certain that the speed and direction of rotation of the attachment conform with the speed and direction of rotation of the machine specified by the manufacturer.

Before switching the PTO shaft ON, make certain that there are no persons or animals within the machine's danger zone. Never switch the PTO shaft ON or engage it if the forage harvester's motor is switched ON.



Safety Instructions

Ejection of stones and foreign objects

To increase the safety of the driver, only use the header with an enclosed driver's cab. The area to be mown must be free of foreign objects. Stony or rocky ground should not be mowed. If this is unavoidable, additional safety measures must be taken, e.g.:

- Fit Macrolon panels to the floor, sides and rear of the driver's cab or fit finely meshed grilles to the outside.
- Adjust the cutting height such that any contact with stones or rocks is excluded.

Never switch the header ON when persons are standing in the vicinity of the machine.

Foreign objects can be ejected from the machine, even if the machine is in proper use. Stones and other foreign objects that are caught up by rotating parts can be thrown over great distances. Exclude all persons from the danger zone.

The guard plates and protective aprons lessen the risk of stones and foreign objects being ejected. It must therefore be ascertained that all protective devices are fitted and in perfect condition when the header is in use.

Check the state of the protective aprons at regular intervals. Worn, damaged or missing parts must be replaced immediately.



Safety Instructions

Precautions for use and shunting

Before changing over from transport to working position and vice versa, ensure that no persons are within the manoeuvring zone of the machine.

Precautions for maintenance and repair work

Before carrying out any work or intervention, shut off the engine, remove the ignition key, wait until all moving parts have come to a complete standstill and apply the parking brake. Depressurise the hydraulic system.

Prop up and secure any machine parts that are raised for maintenance or repair.

Disconnect all electric lines from the towing vehicle before working on the electric system or before welding on the transporter.

Repairs on parts under strain or pressure (springs, accumulators, etc.) must be carried out solely by specialist staff who have the necessary qualification and special tools.

Wear protective gear that suits the work at hand (gloves, footwear, goggles, helmet, ear protectors, etc.).

Do not weld, solder or use flame cutters near pressurised liquids or highly flammable products.

Only use original spare parts to ensure your personal safety and correct functioning of the machine.

We strongly recommend to have the machine and its parts and fastening elements checked by your authorised Zürn Harvesting sales partner after each season.



Safety Instructions

Precautions for travelling on public roads

Dimensions

The combination must comply with local requirements relating to maximum dimensions for travel on public roads. In case of doubt, seek information beforehand from the relevant authorities.

If the combination exceeds the maximum dimensions and yet has to be transported on public roads, contact the local authorities to obtain a special permit before you travel on public roads.

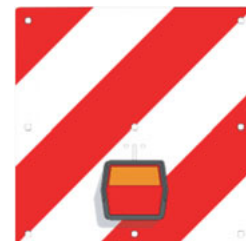

Transport position

Before travelling on public roads, place and secure the machine on a suitable transporter, following the instructions in this manual.

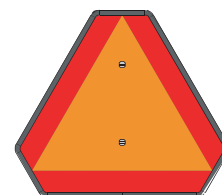

Lights and warning devices

Before travelling on public roads, ensure that all required lights and warning panels are in place.

Check these devices for proper functioning and visibility. Replace any missing or damaged parts immediately.

Maximum speed

Always comply with the current regulations regarding speed limits on public roads.

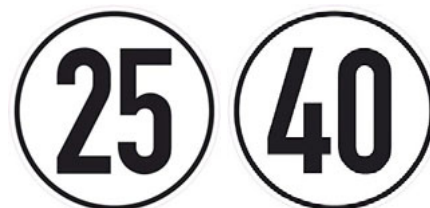

When travelling on public roads, always comply with the relevant regulations.

Before travelling on public roads and before each use check the header transporter and the towing vehicle for road safety and operational safety!



Safety Instructions

Modifications to the machine

Any modifications to the machine and its optional features must be approved in writing by the manufacturer. The warranty and product liability will be voided, if such modifications are carried out without the written approval of the manufacturer.

The manufacturer's liability refers to the original condition in which the vehicle is delivered to the country of destination as contractually agreed by the manufacturer.

Any unauthorised modifications to this machine render any manufacturer liability for any consequential damage null and void.

Welding

Ensure that any type of welding is carried out by qualified and certified welders. Welding must not affect the warranted properties of the steel structure. In case of non-compliance, the manufacturer shall consider the weldment as an unauthorised modification to the transporter.

Bolted assemblies

Observe the property class when fastening and replacing bolts and nuts (see the table in this manual and the parts list).

After assembling the transporter, tighten all bolts to the proper torque.

For special torques read the assembly instructions or ask the manufacturer.

For any torques of regular bolts refer to the table.

Self-clinching bolts and nuts must be replaced by new ones after they have been removed during a repair.

This is necessary as nuts with a self-clinching fastener lose their holding power with each reuse.

Safety Instructions

Using original parts

Only use original parts sourced from the manufacturer. This is mandatory. Using third-party parts voids the manufacturer warranty including for consequential damage resulting from this.

Waste prevention

Never pour environmentally hazardous products (oils, greases, filters, etc.) into a sink or empty them onto the ground or in other spaces. Never burn or throw away used tyres. Have waste disposed of by specialised disposal companies.

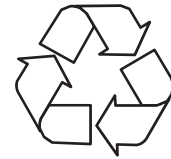

Safety Instructions

Safety decals

Safety decals are placed in various locations on the machine. Always follow these instructions! The decals alert operators to potential hazards and provide rules of practice to cut out any risk of an accident.

Keep the safety decals clean and legible and replace them immediately when damaged, worn or lost.

Operating instructions

The operating instructions contain all the necessary information for the safe use of the machine. To avoid the risk of accidents, read the operating instructions carefully and follow all instructions.

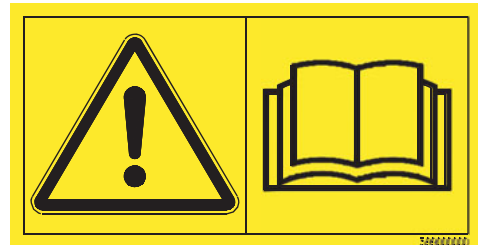

Working on and intervening in the header

Before carrying out any type of work on or intervention in the header, disengage the clutch in the driveline, shut off the engine, remove the ignition key, wait until all moving parts have come to a complete standstill and apply the parking brake.

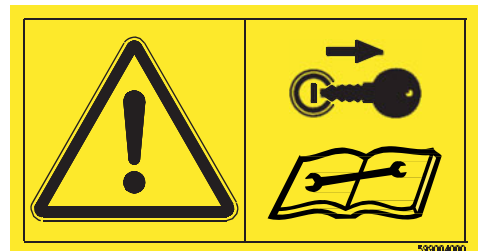

Parking the transporter

Secure the transporter with a wheel chock before removing it from the towing vehicle or parking it.

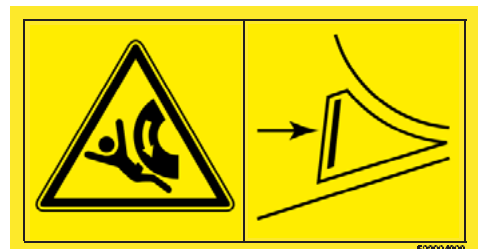

Safety Instructions

Placing the header on the transporter

When placing the header on the transporter, keep clear of the danger zone between the header and the transporter.



The header is lifted

Keep clear of the header swing area when placing it on the transporter.



Risk of crushing

Keep clear of the drawbar unit and all steering elements (e.g. turntables, steering rods) while operating the machine. Risk of being crushed at a full lock turn.

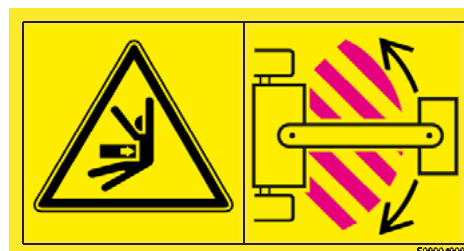

Retighten the wheel bolts

Retighten the nuts after the first journey.

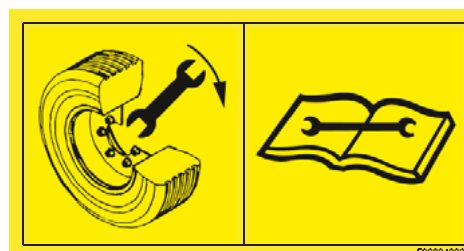

Safety Instructions

Ejection and foreign objects

Stones and other foreign objects can be thrown out over long distances. The protective devices must always be in place and in a perfect state. Always keep a safe distance from the machine.

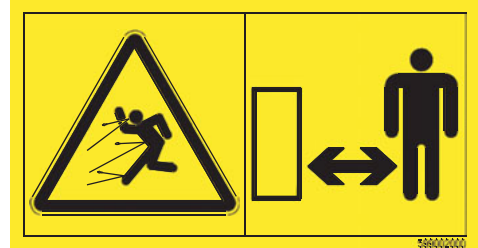

Do not open guards

Do not open or remove protective devices during operation or while the engine is running.



Do not open guards

Do not open or remove protective devices during operation or while the engine is running.



Rotating Auger

Never reach into the rotating auger.

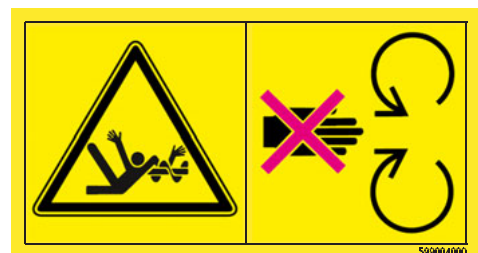

Important information

Each sunflower attachment is accompanied by a laminated overall drawing of the product in A3 format. This overall drawing contains important dimensions and instructions for the installation of the sunflower attachment to the header. These must be taken into account for correct and successful installation.

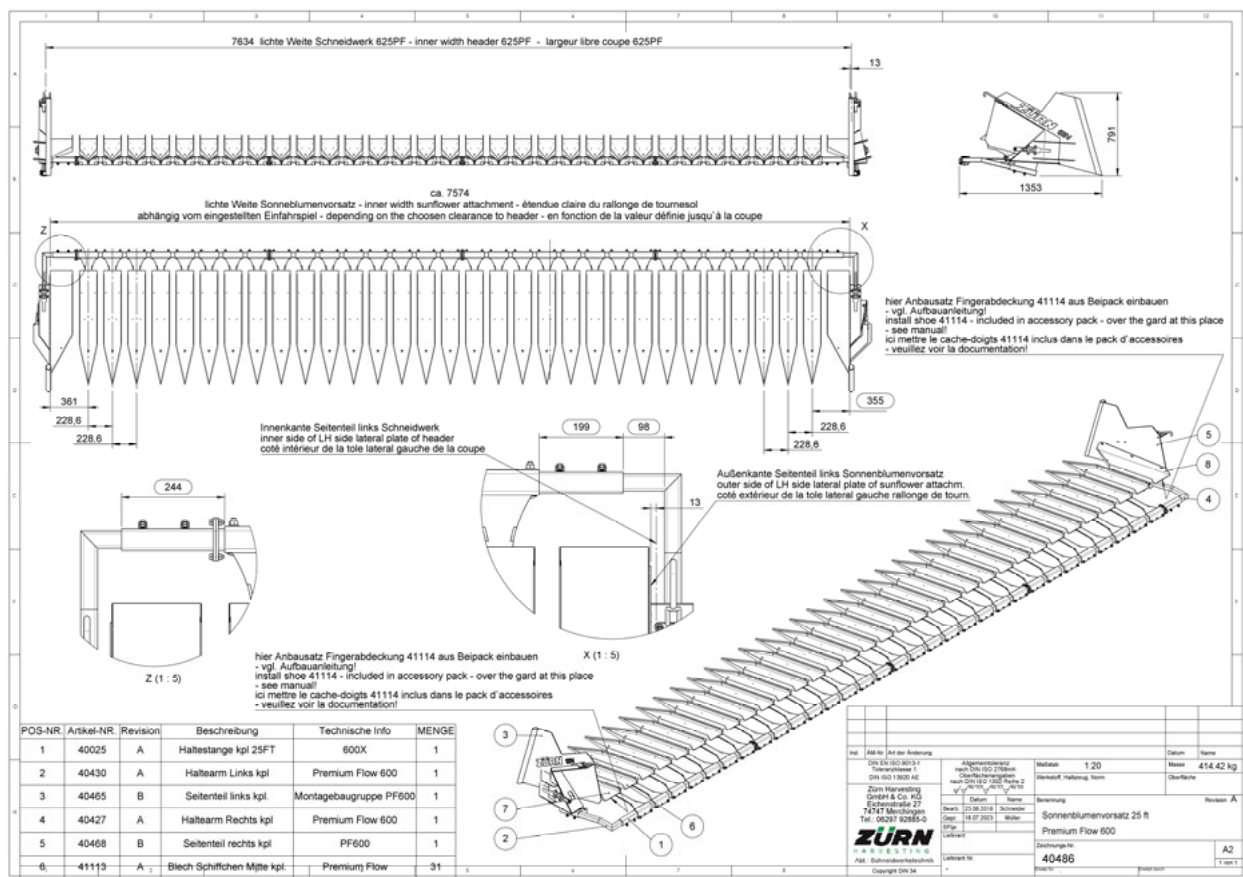

Assembly instructions

Assembling the supporting bars

The individual sections of the supporting bars are bolted together as shown in the illustration below. The flanges are attached with five M8x25 serrated flange bolts and M8 serrated flange nuts.

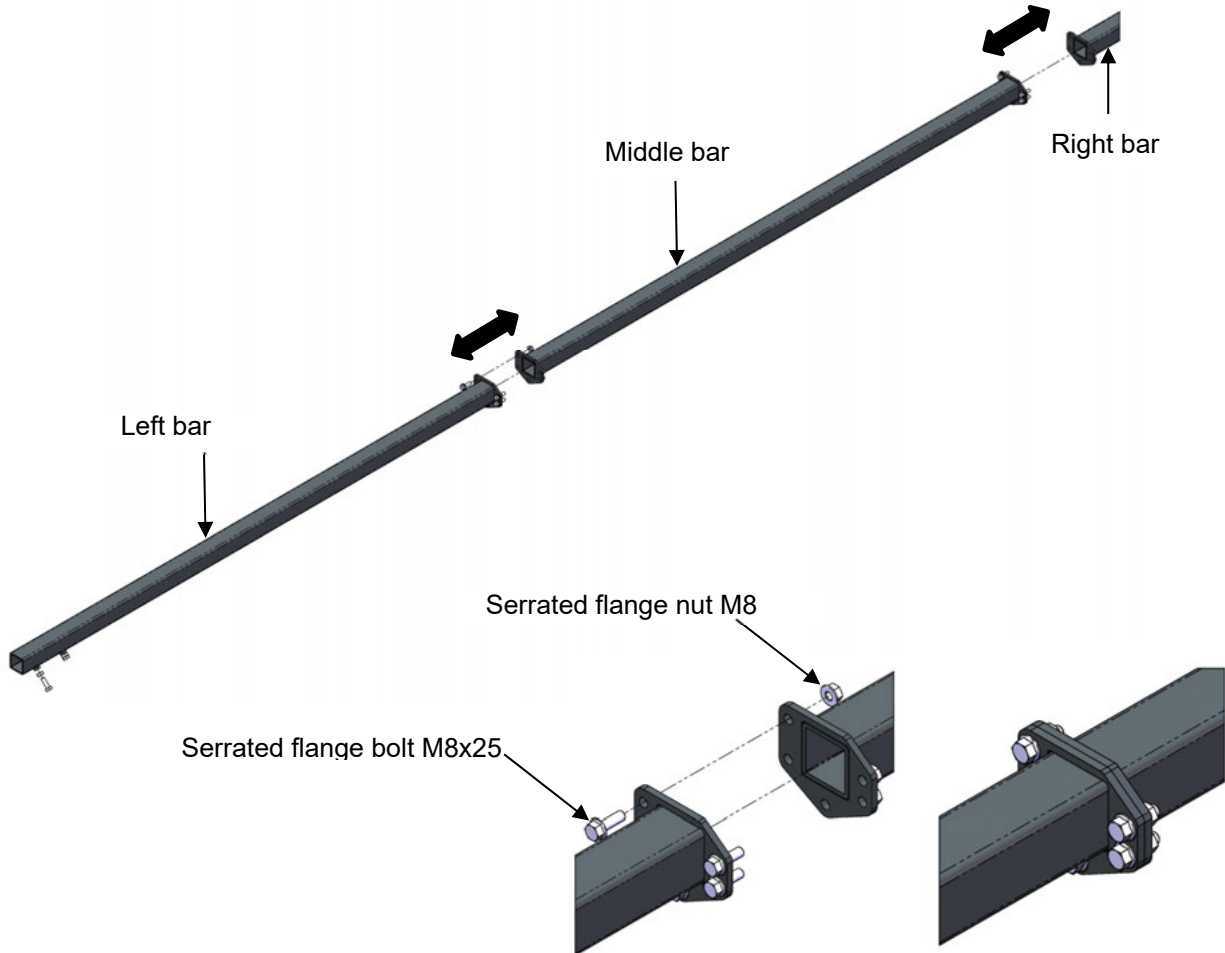

IMPORTANT!

Ensure the flanged bar ends mate exactly.

Put the supporting bars on several stacks of pallets, about waist-high, placed next to each other. This makes it easier to retract the header with the combine.



Depending on the header length, the number of supporting bars and the length of the right supporting bar vary. For numbers and dimensions please refer to the tables on pages 46 to 49



Assembly instructions

Assembling the supporting bars

The two supporting arms are attached to either end of the assembled supporting bar. The left arm is attached with two M10x30 hex bolts and M10 nuts as specified. The right arm is merely pushed into the bar but not bolted down as yet.

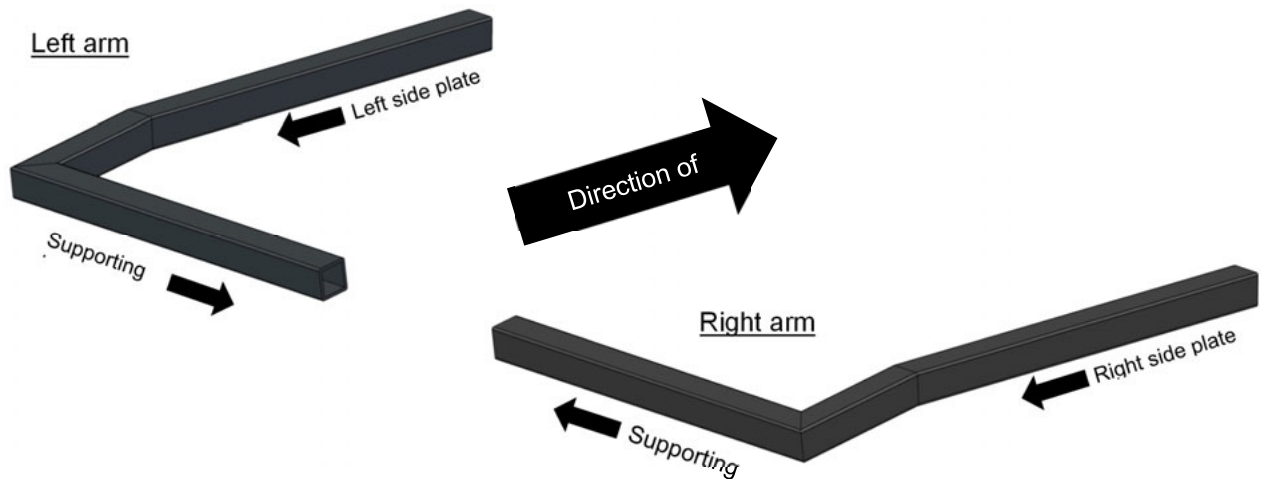

The arms are merely loosely attached but not bolted yet. Adjust the distance x on both arms later after the pans are installed on both sides. Only then fix the supporting arms by tightening the two M10x30 hex head bolts (page 39).

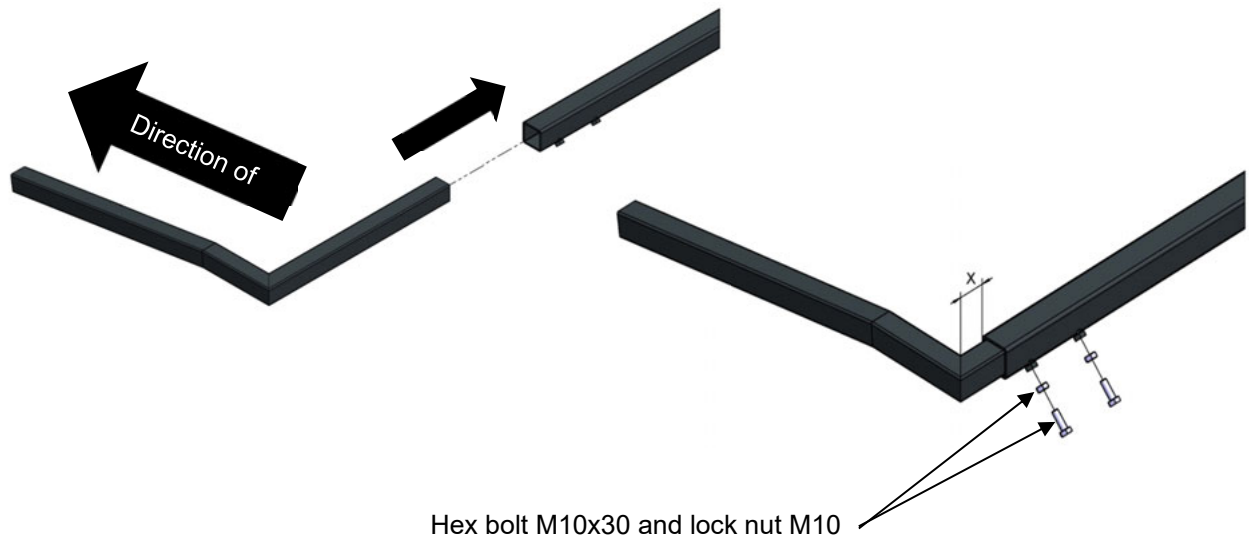

Cutting width	618PF	620PF	622PF	625PF	630PF	635PF
"X" measure	98mm	17mm	98mm	98mm	98mm	17mm

Assembly instructions

Attaching the side plates

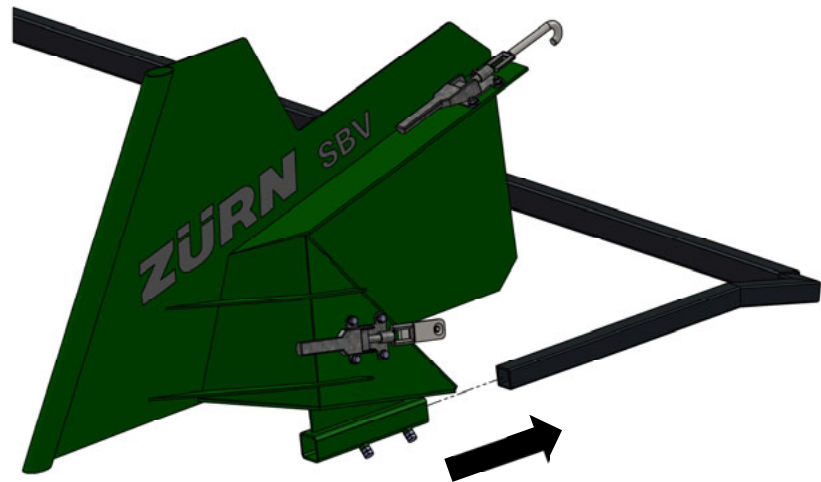

The side plates are pushed as far as possible onto the supporting arms so that the supporting arms stick out from the supporting tube.



The assembled supporting bars, arms and side plates on stacks of pallets.

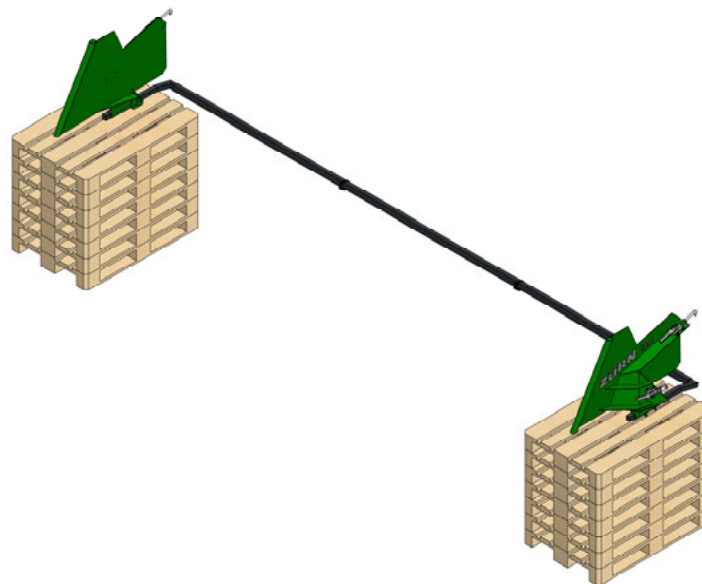

Assembly instructions

Preparing the header for attaching the sunflower extension

Installing the brackets that accommodate the toggle clamp hook

Remove the two swathing plates from both side plates. On each side plate, position the top bracket in such a way that it will not be in the way when you re-attach the swathing plate. Mark the four holes in the brackets on the top of the side plates and then drill the 11mm holes.

Next, install each bracket for the toggle clamp hook in these holes using four M10x25 serrated flange bolts and four M10 lock nuts.

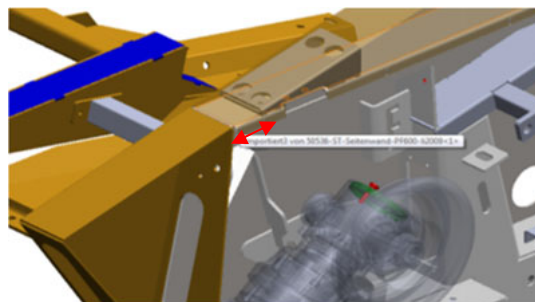
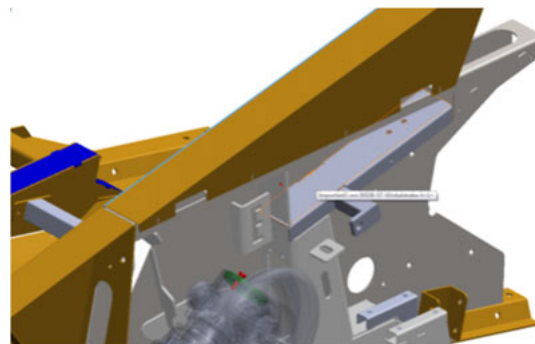

Next, cut a square hole (40x30) into the swathing plates directly behind the bracket. This is where you attach the hook of the toggle clamp.

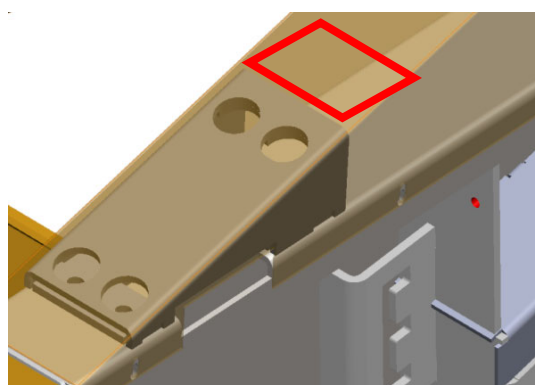

Assembly instructions

Preparing the header for attaching the sunflower extension

Welding the latches in place

Remove the triangular tips from the header. Slide the tips into the side plates of the sunflower extension. Position the latches on the header side plates and weld them to the header. Size and type of weld: Fillet weld $a=3$

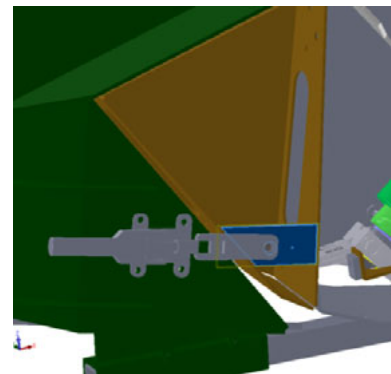

Welding the stud plates for the central supports

Depending on the cutting width, it is necessary to weld a stud plate into one (18-22ft), two (25 and 30 ft) or three drop out holes. Remove the stainless steel plates from these openings and fold up the belt units. Weld the front end and the bottom of these (unpainted) plates in place from above. Make sure they are flush with their surroundings. Size and type of weld: Fillet weld $a=3$

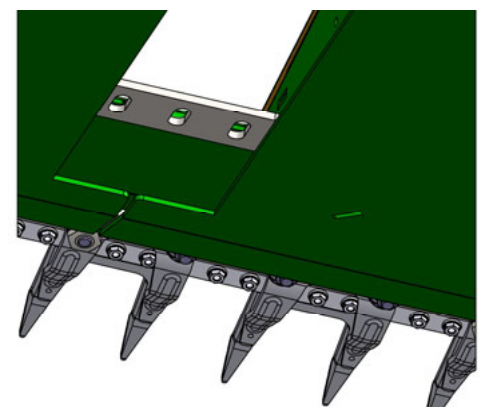
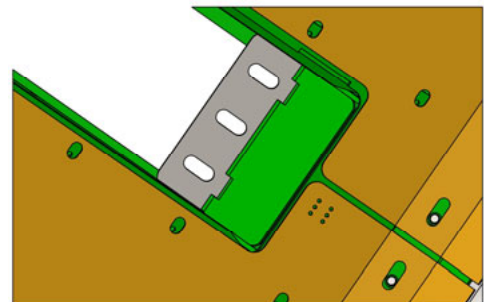

Assembly instructions

Attaching the sunflower extension to the header

Remove the circlip from the hydr. cylinder that controls the feeder house position. Then drive the header into the side plates of the sunflower extension. Attach the extension to the header by closing the toggle clamps.

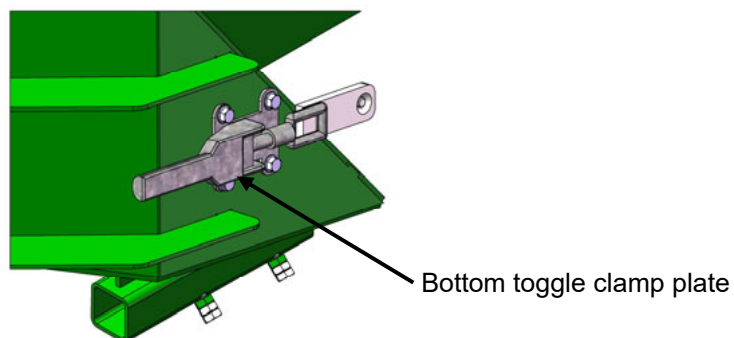
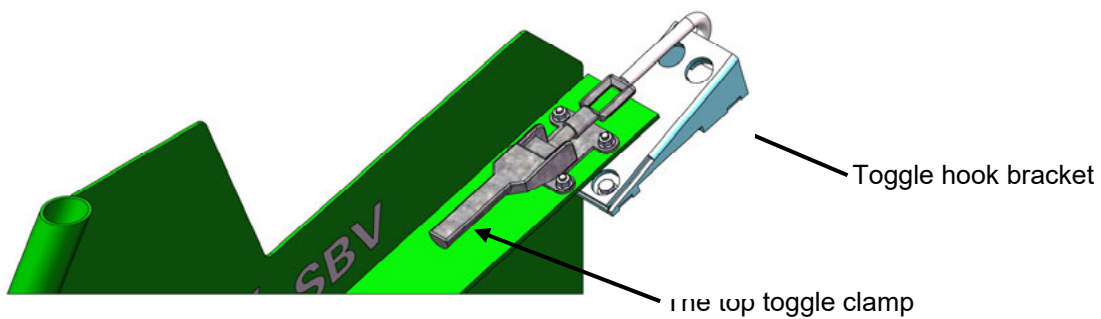
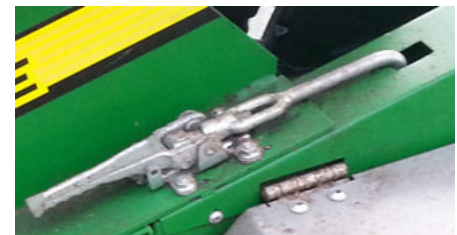

Assembly instructions

Fitting the pan holders

Raise the header to a comfortable height and prop the supporting tube in the middle. Secure the feeder house so it cannot drop. To do this, place the circlip around the ram that operates the feeder house.



Next, fit the pan holders to the supporting bar. Starting from the left side, make sure that the **fifth visible guard** (18ft (5.50m), 22ft (6.70m), 25ft (7.60m) and 30ft (9.15m)

or the **fourth visible guard** (20ft (6.10m), 35ft (10.70m) makes contact with the recess in the pan holder when you push the supporting bar to the rear.

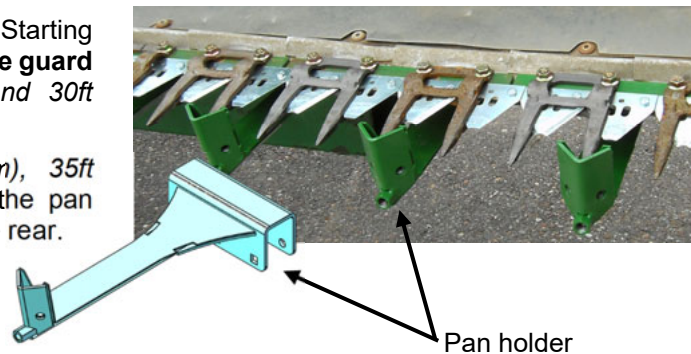

The pan holders are placed on the supporting tubes as shown in the illustration, and bolted down with two M12x80 carriage bolts and two M12 serrated flange nuts.

Do not tighten the nuts yet!

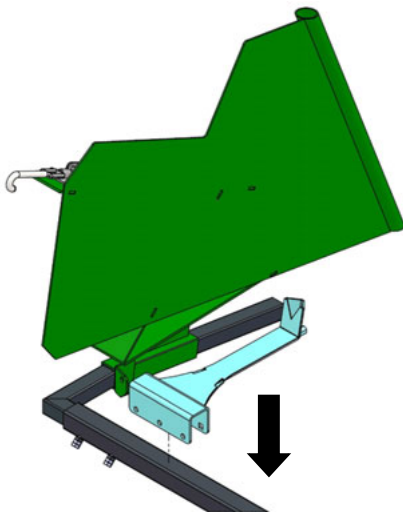

The gap (X) between two holders is approx. 30mm

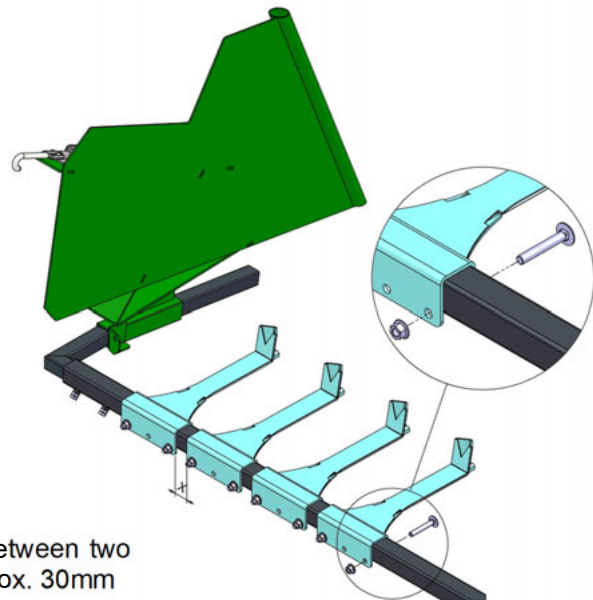

Note!

Do not yet tighten the serrated flange nuts on the pan holders



Assembly instructions

Installing the central support

After all pan holders are attached to the supporting bar, raise the header and refit the circlip on the hydr. cylinder.



Next, push the supporting bar with the pan holders attached to it under the header. Push it as far as possible and align the pan holders in such a way that the guards contact the pan holder recesses in the middle. Distance must be approx. 5 mm. Contact should be avoided.

See the instructions below.

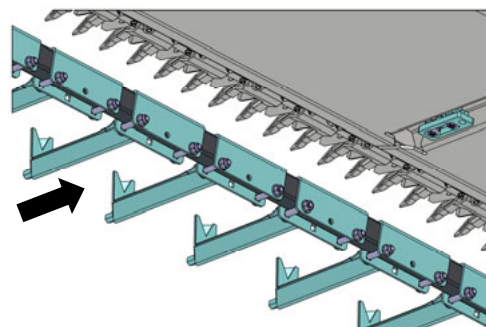

The front of each supporting arm is flush with the supporting tube of the side plate. Next, clamp these with the M10x30 bolts

and as explained on page 21.

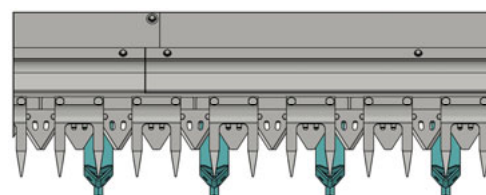

The angle is bolted to the pan holders with the two M12X95 carriage bolts and two M12 serrated flange nuts.

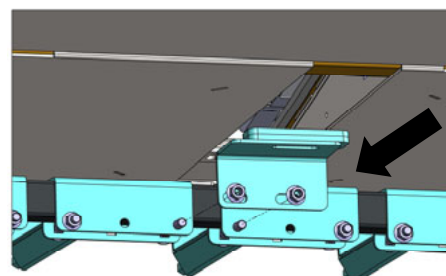

The angle and the spacer plates are bolted to the plate that was welded to the drop out hole using an M12X40 serrated flange bolt and an M12 serrated flange nut (see page 24).

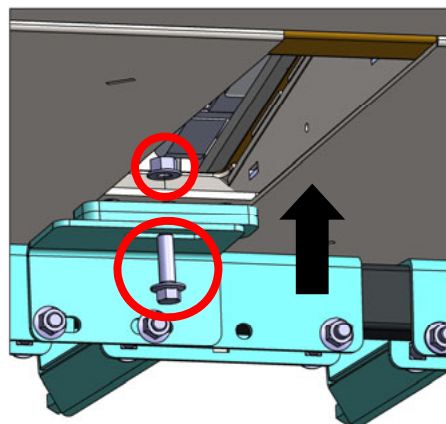

Assembly instructions

Installing the central support

Attach the stays (*with the lock nut attached*) to the pan holders.

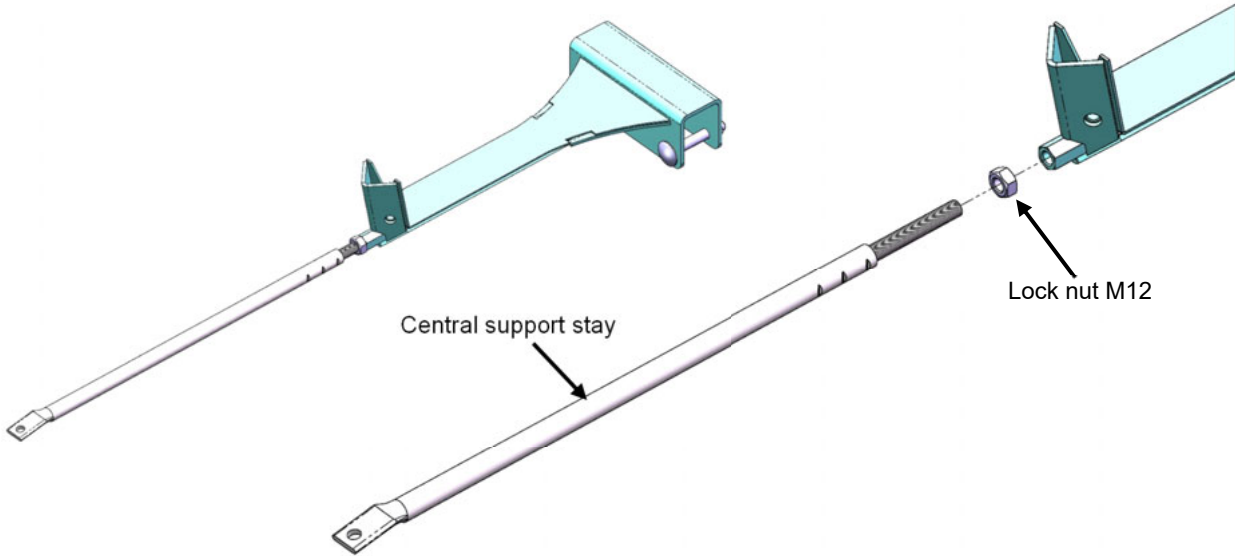

Note!

Do not tighten the M12 lock nut until the pans are fitted.



Test on one pan to see how deep the stay must be inserted into the pan holder ("X") before the hole in the stay aligns with the hole in the pan so you can insert the bolt.

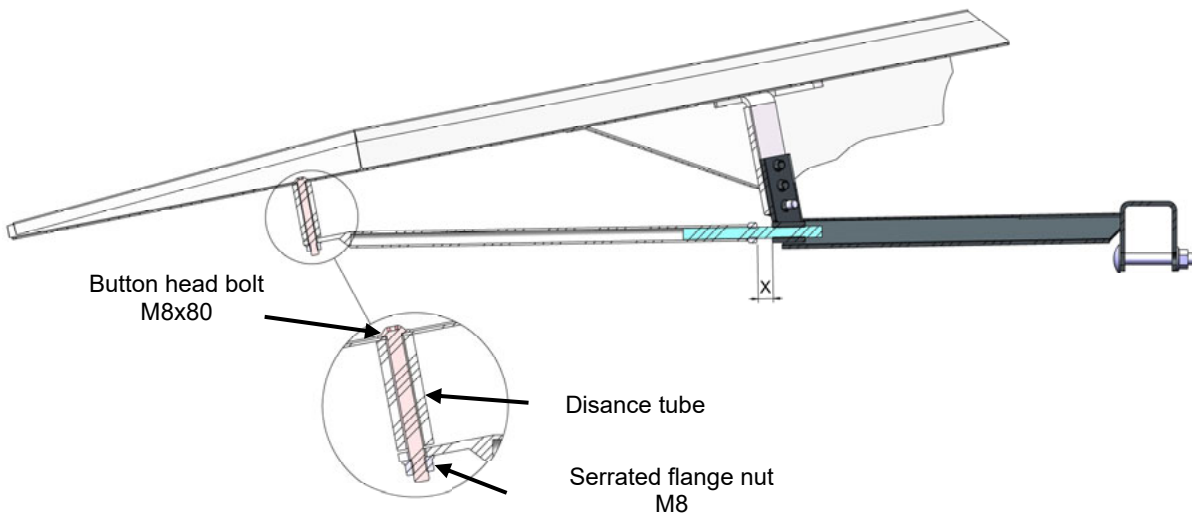

Assembly instructions

Mounting the central pans

The pans are attached to the pan holders with two M10x20mm serrated flange bolts. Adjust the height so that the guard shoes rest on the guards.

To increase the stiffness of the pans during the harvesting process, align them so that they are attached as far as possible to the front of the pan holder and have contact with the header's table at the back as far as possible over their entire width.

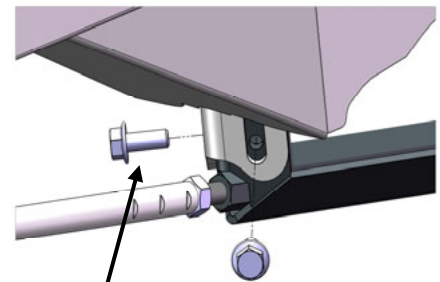
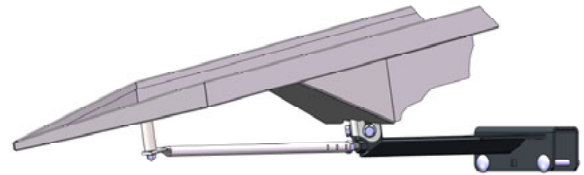

Serrated flange bolt
M10x20

Make sure that the guards are completely covered by the integrated shoes of the pan holders and no guards are visible in the gaps between the pans



The central stay is attached to the tip with two M8x20 button head bolt and three M8 serrated flange nut.

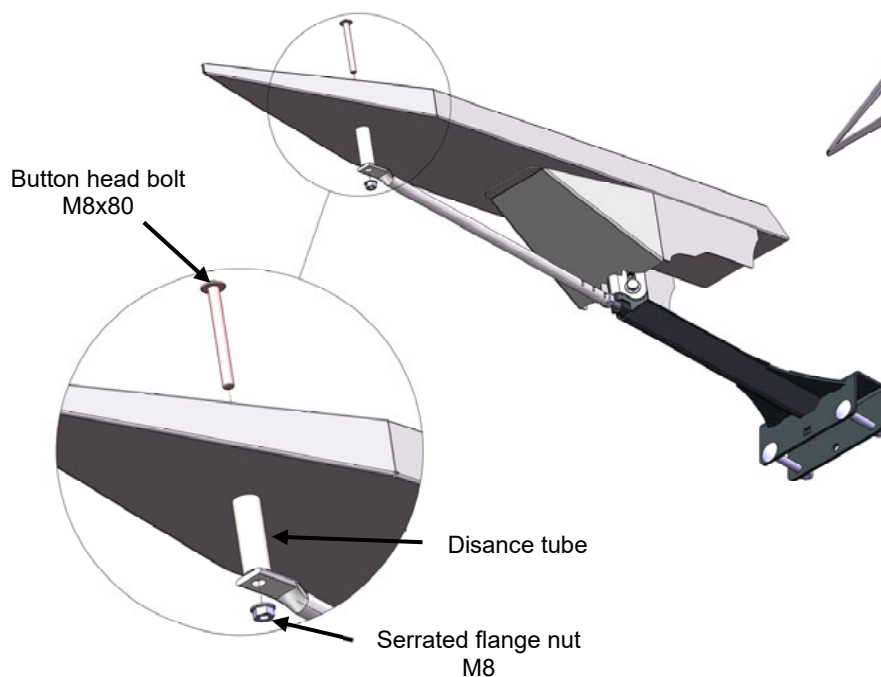

Assembly instructions

Before carrying out any subsequent work, make sure that the two side parts of the sunflower attachment are in correct contact with the tips of the side parts of the header

Start by attaching the central pans on the left side of the header. Be sure to pay attention to the distance between the supporting bar and the side part of the sunflower attachment as well as the distance between the supporting bar and the holder of the first center pan on the left side of the header. These dimensions are given on the laminated overall drawing of the sunflower extension.



Situation at 2-finger pan left hand side

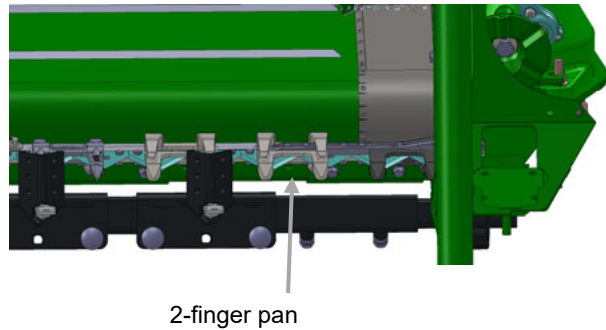

Situation at 3-finger pan left hand side

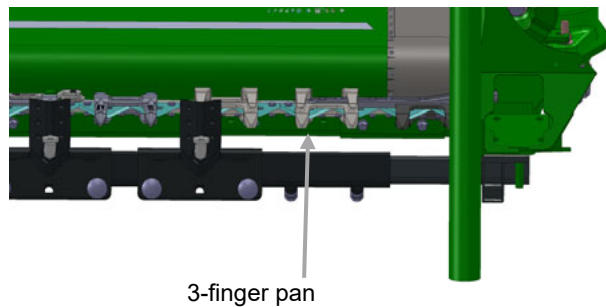

Align the first pan holder according to the dimensions on the laminated drawing and slide the first central pan onto the fingers from the front.



Assembly instructions

On the left side of the header, the backs of the fingers are higher and shaped differently than the other fingers of the cutting system. These fingers determine the height of the first central pan and thus – if all other pans are aligned with it – the height of the central and the outboard pans to the cutting system.

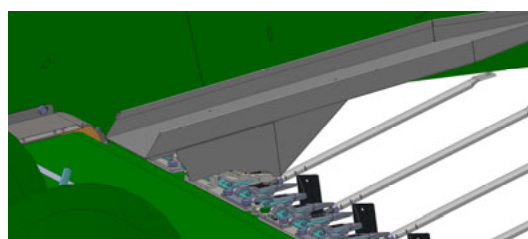
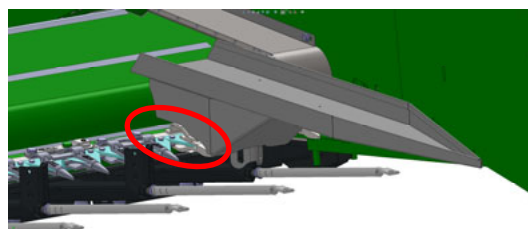

Slide all the other central pans onto the fingers from the front.

Make sure that the finger cover grips the fingers laterally and from below.

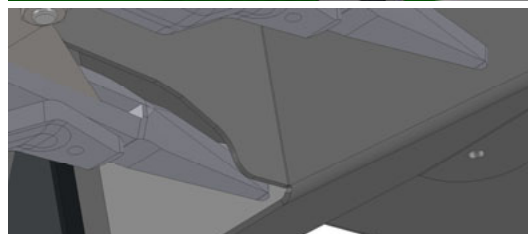

If this is not the case, the position of the supporting bar can be changed forwards or backwards with the screwed-on pan holders relative to the fingers.

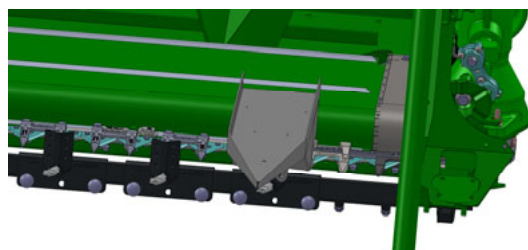

Assembly instructions

Install the two screws, but do not tighten them yet and adjust the central stay to the position of the pan. The pan must fit in full contact into the prism of the pan holder at the front and the finger cover must cover the fingers at the bottom and sides.

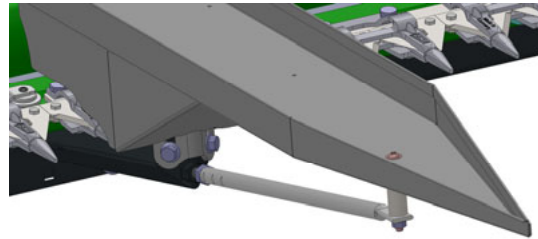
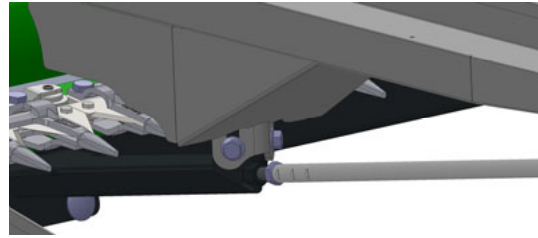

When adjusting the central pans, make sure that they are at a sufficient distance from the conveyor belt or the tunnels on the conveyor belt. Please note that the front deflection roller of the conveyor belt can shift forward due to stretching of the belt.

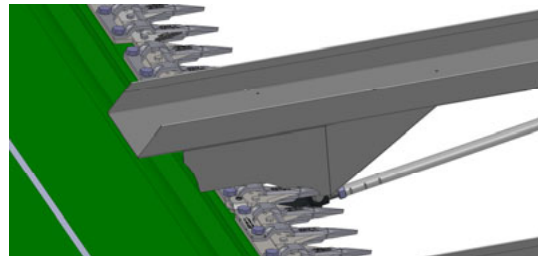
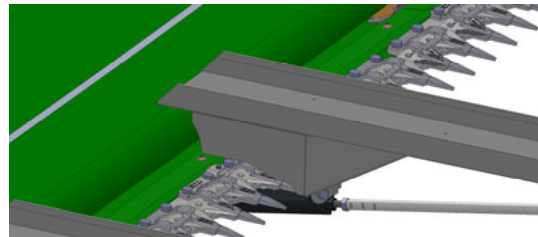

Assembly instructions

Also check in the areas where the central pans cover the covers between the conveyor belts to see if there is sufficient distance.

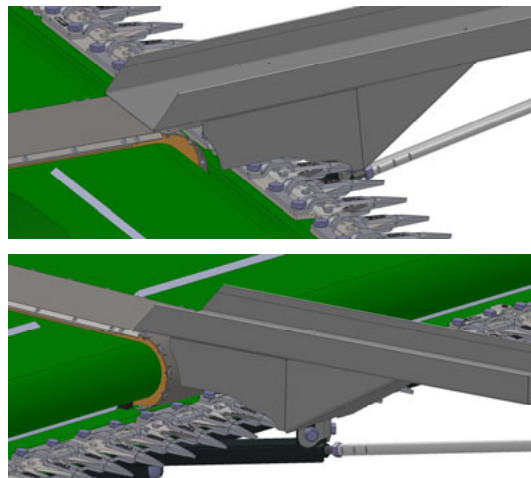

If all pans are correctly aligned and have a sufficient distance to the conveyor belts and their covers, tighten the fasteners on all pans and on all pan holders.

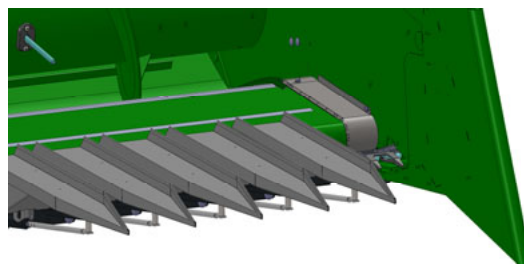

Assembly instructions

Attaching the outboard pans and aligning the side plates

Again, make sure that the two side plates of the sunflower attachment are correctly aligned with the tips of the side panels of the header.

Check again that the central pans are evenly aligned with each other in height.



Next, prepare the left and right outboard pans for attachment to the side plates. Drill a hole $\varnothing 9$ mm in each outboard pan - whether it is a 2- or 3-finger pan - according to the dimensions given below. This hole is used to screw the central stay to the outboard pans.

As a reference for the dimension, note:

Distance from the trailing edge of the outside pan and the distance from the contact surface to the side panel respectively.

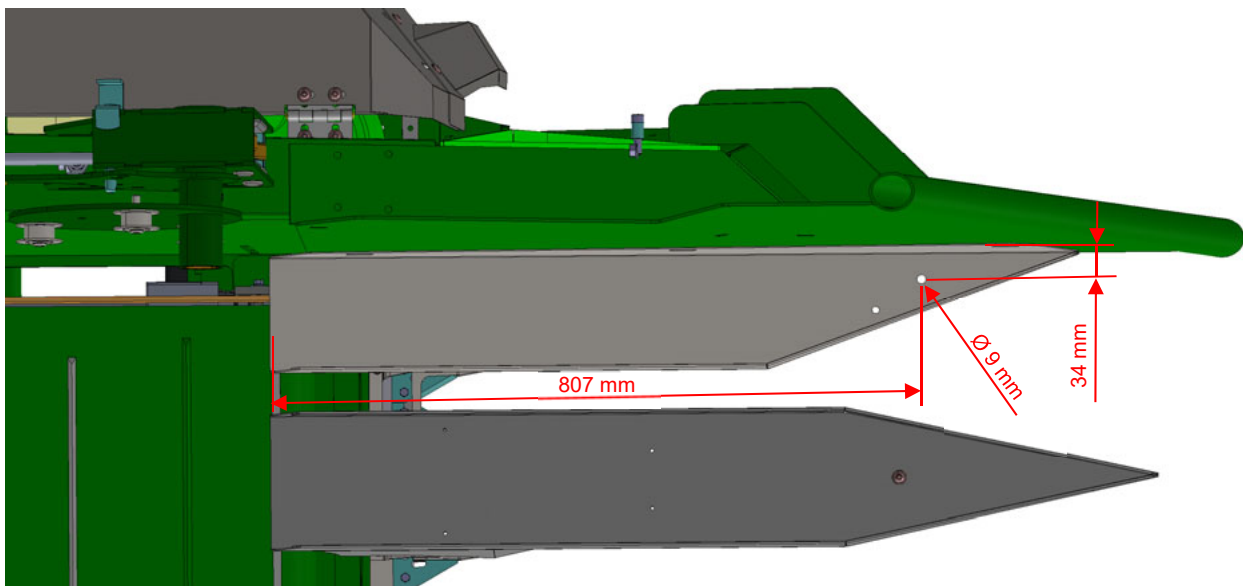

Assembly instructions

Now align the height of the two outboard pans with the central pans and bring the trailing edges of the outboard pans congruent with the trailing edges of the central pans.

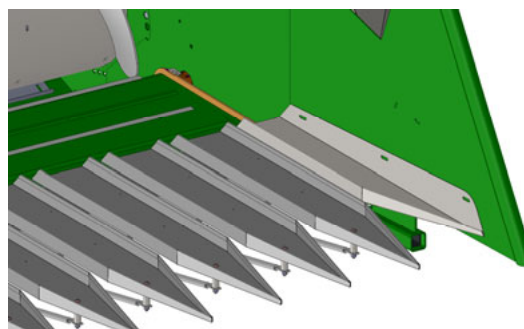

Make sure that the outboard pan does not foul with the guide tube of the side plate.

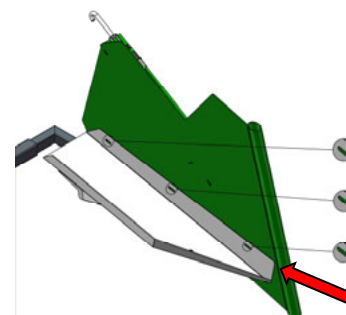

Fix the outboard pans to the side plates by means of screw clamps and drill the elongated holes of the outboard pans on the side plates with a drill \varnothing 9 mm. Screw the two outboard pans with M8x25 lens head screws and M8 locking nuts.

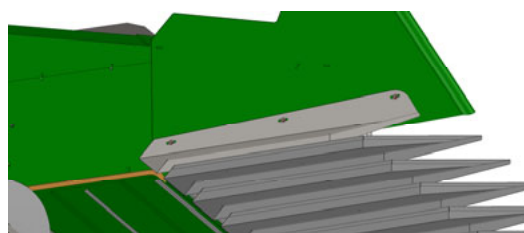
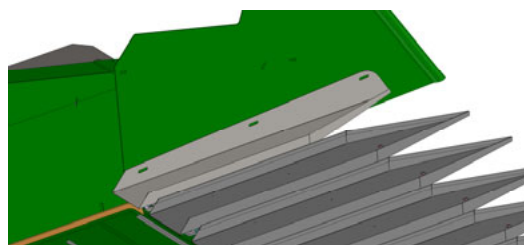

Be sure to mark the position of the outboard pans on the side plates, as the outboard pans will have to be dismantled again later.



Assembly instructions

Next, mount the central stay under the two outboard pans. To do this, use the two M12 nuts, the spacer tube, the M8x80 semicircular head screw and the matching M8 hexagonal nut with flange.

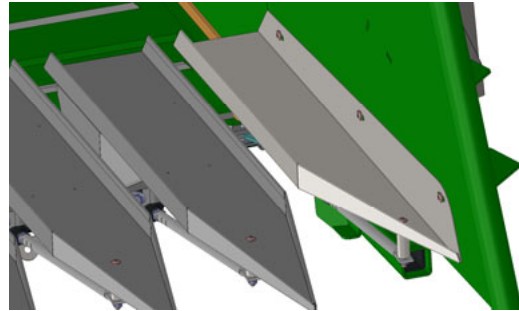

From model year 2023, all sunflower attachments are equipped with adjustable finger covers under the outboard pans.

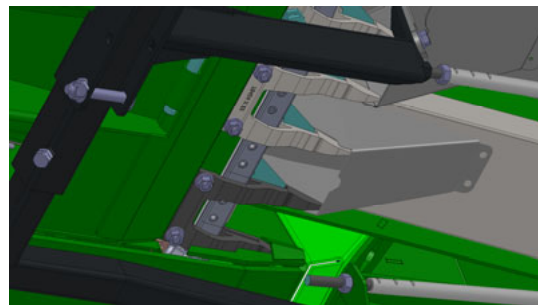

After aligning and attaching the outboard pans to the side plates, the finger covers must be attached to the outboard pans.

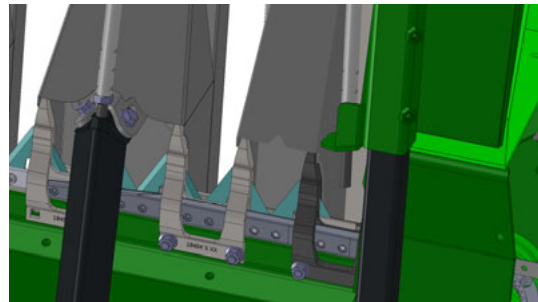

Slide the finger cover over the fingers and align it with them so that all fingers are evenly covered and the finger cover is centered on the flanks of the fingers.

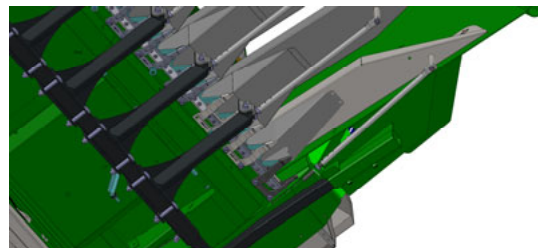

Assembly instructions

Draw the holes (there are 4 or 6 holes, depending on the size of the finger cover) of the finger cover on the outboard pans and dismantle the outboard pan. Now drill holes in the outboard pan at the marked points. The hole diameter should correspond to the one in the finger cover.

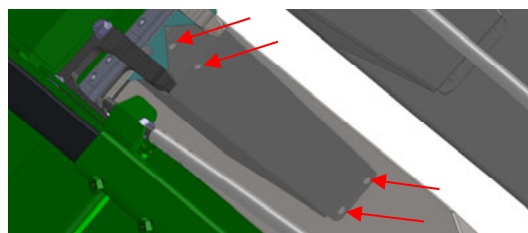

After drilling out the outboard pans, attach the finger covers to the outboard pans and reattach the outboard pans to the side plates according to the markings you have made. After aligning all these parts, tighten all fasteners.

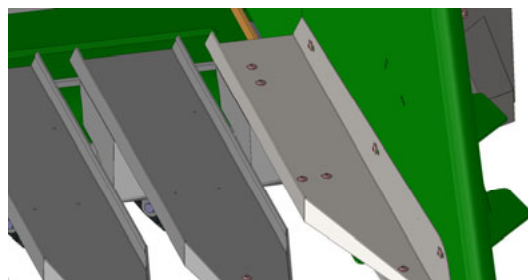
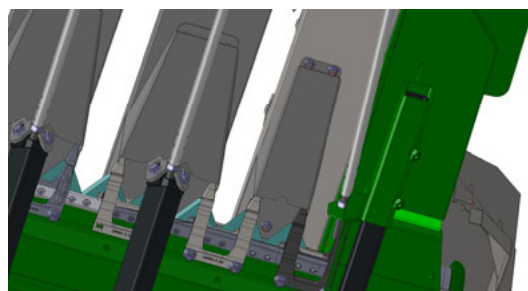

Assembly instructions

Attaching the outboard pans and aligning the side plates

Bolt the outboard pans to the side plates using M8x20 button head bolts and serrated flange nuts.

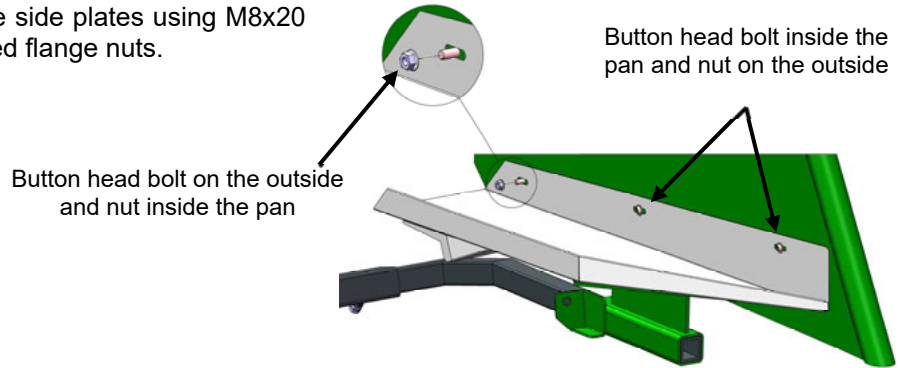

Next, support the two outboard pans with stays.

To do this, use one M8x25 button head bolt and one M8 serrated flange nut as well as two M12 nuts and the corresponding washers to attach the central stay to the angle on the side plate.

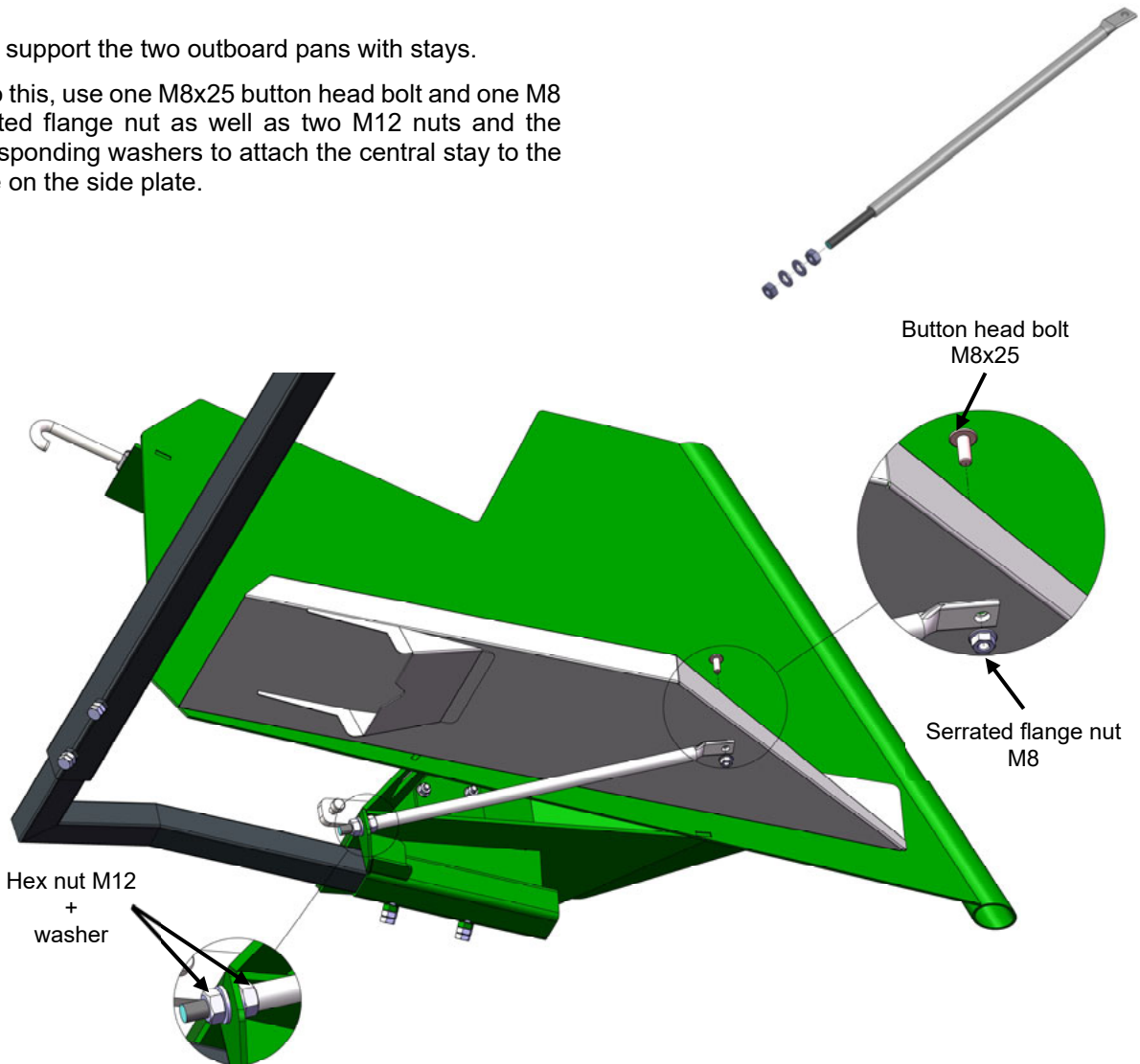

Assembly instructions

Attaching the side plates and the supporting arms

After aligning the side plates with the help of the pans, attach and secure all parts.

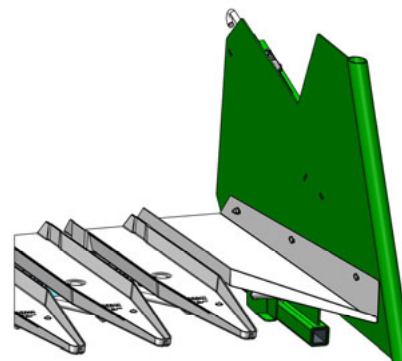

To do this, attach the two side plates to the supporting arms with the M10x30 bolts and the M10 lock nuts supplied.

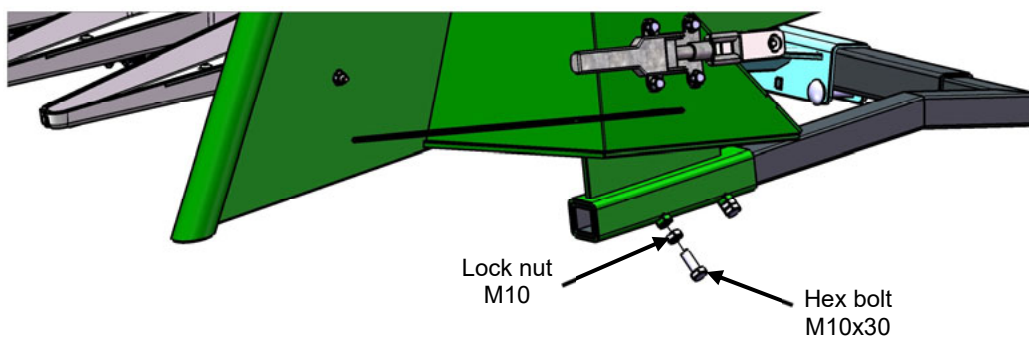

Then attach both ends of the supporting arms to the supporting bars (see page 21) using the M10x30 bolts and M10 lock nuts supplied.

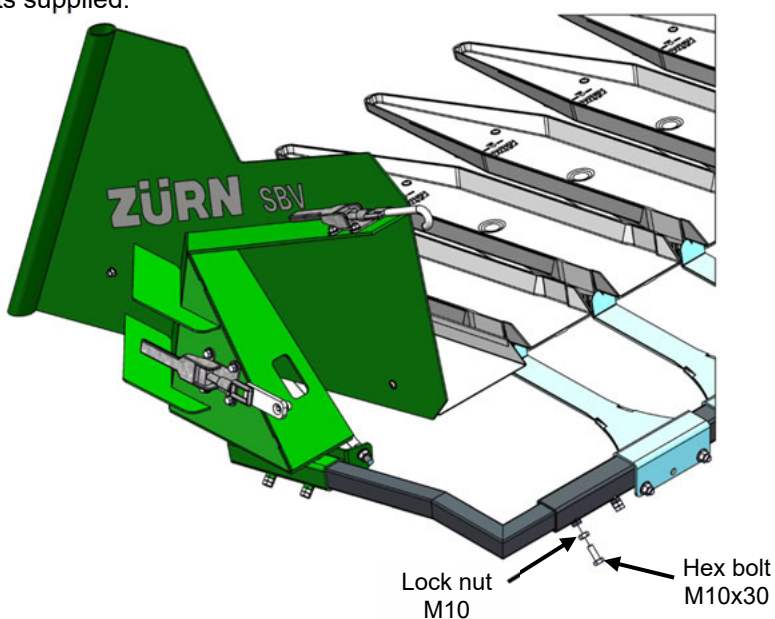

Assembly instructions

Installing the reel boards

Next, install the reel boards. As a first step, remove three tine bars and their mountings from the reel.

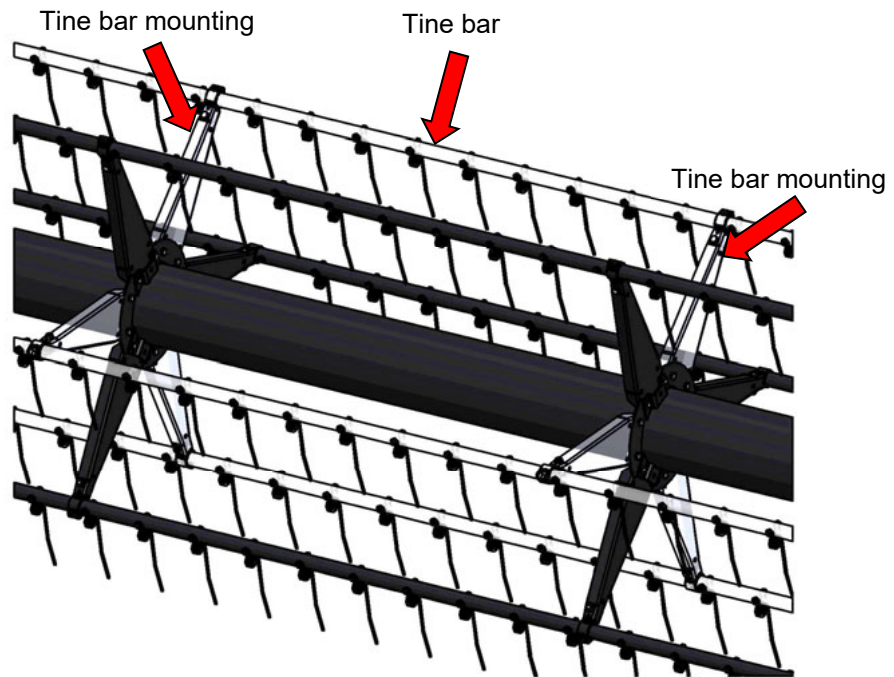

Assembly instructions

Installing the reel boards

Remove the two outer tines in each tine section and mark the two holes on the reel board.

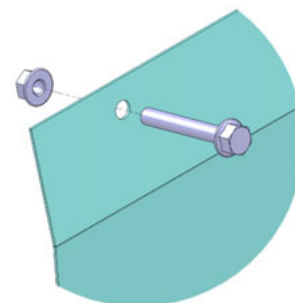

Drill the holes into the plates and fit the plates. Use the M8x55 flange bolt.

Proceed in the following order:

1. Flange bolt M8x55
2. Guard
3. Reel tube
4. Flange nut M8
5. Reel board
6. Serrated flange nut M8



The bolts remain on the reel when the plates are removed from the reel.

Assembly instructions

Installing the central support

The two reel supports are mounted to the right and left side of the hydr. cylinders that raise the reel. The supports prevent the tines fouling with the knife when the reel is in its lowest position.

As a first step, prop or suspend the left side of the reel (e.g. with a crane). This takes strain off the bolt that attaches the cylinder to the reel arm. Then remove this bolt.

Insert the left reel support, refit the bolt and cotter in place. Repeat on the right side of the reel. Attach the right reel support.

When not in use, the support must be secured to the reel arm by fitting the cotter pin.

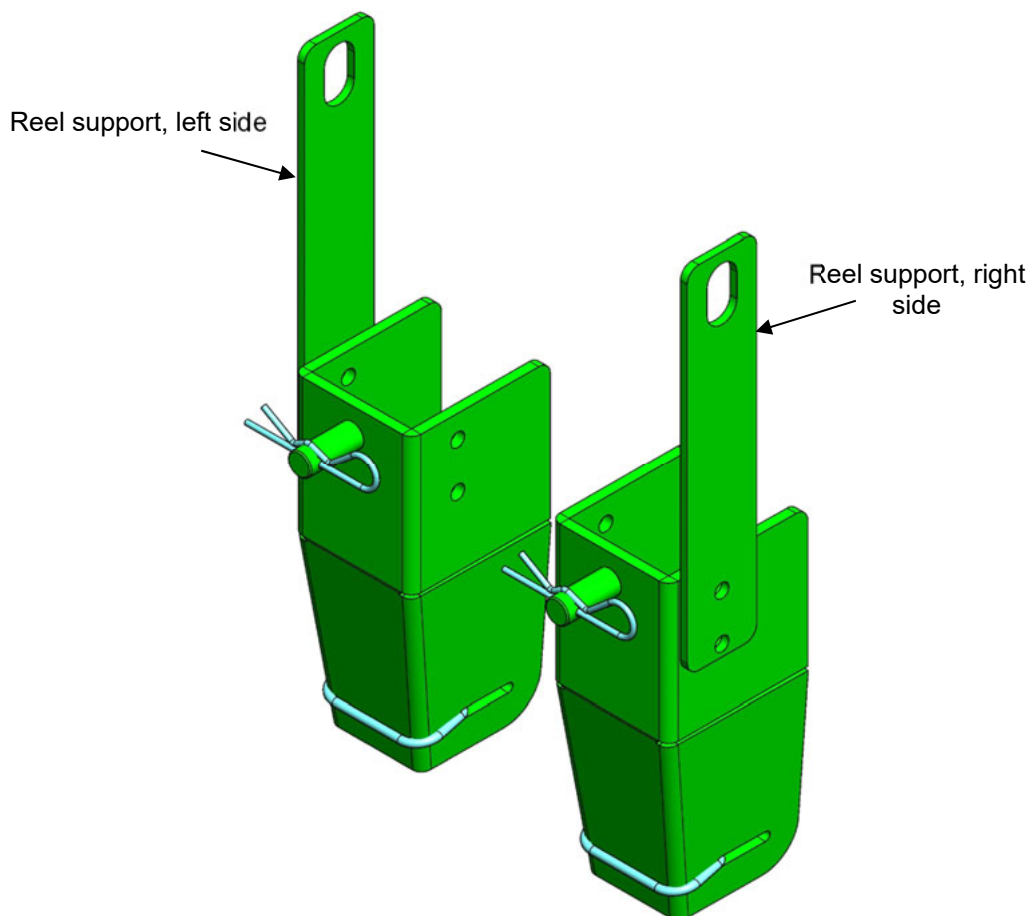

Attachment and removal of the assembled sunflower extension

Removing the extension from the header

Remove the threaded assembly from the central support and lower the header so that you can release the toggle clamps and reverse the header from the extension. Remove the reel boards and re-attach the tine bars to the reel.

Attaching the extension to the header

Place the sunflower extension on the ground and drive the combine, with the grain header attached, into the extension.



Make sure that both guard fingers are inserted in the pan!

Attach the extension to both side plates of the grain header by locking the toggle clamps. Then attach the central supports.

Next, fit the reel boards.

Parts list

Right side plates

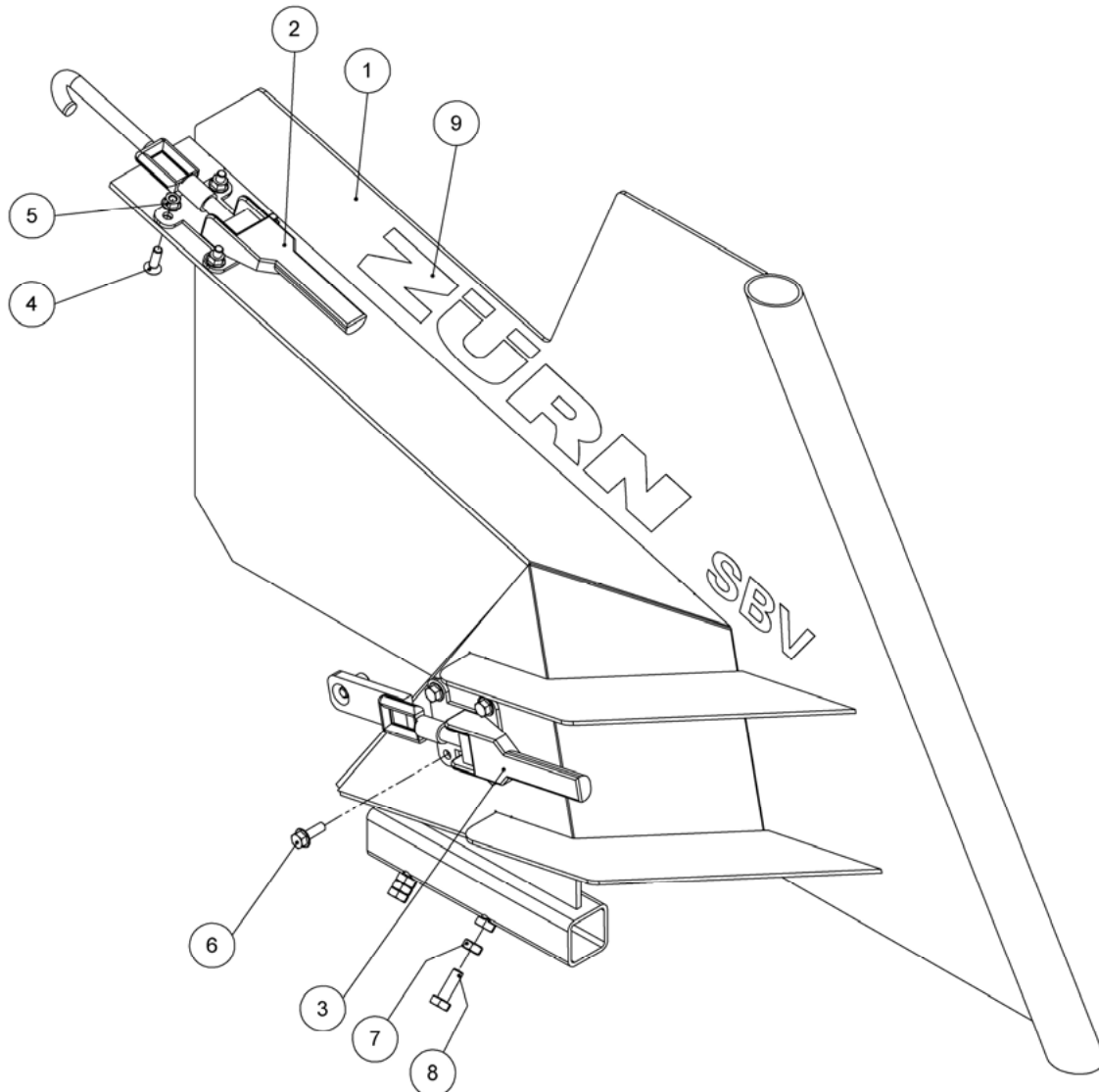

Item	Quantity	Item no.	Designation	Description
1	1	40469	Side plate assembly, right side	
2	1	16126	Hook operating toggle clamp	
3	1	16127	Toggle clamp plate	
4	4	70692	Countersunk bolt	DIN 7991 M8x25
5	8	70005	Hex nut with flange	DIN 6923 M8
6	4	093230	Hex nut with flange	DIN 6921 M8x25
7	2	70015	Hex nut	DIN 934 - M10
8	2	70061	Hex bolt	DIN 933 - M10x30
9	1	41056	Zürn SBV Decale	
1-9	1	40468	Side plate assembly, right side	

Parts list

Left side plates

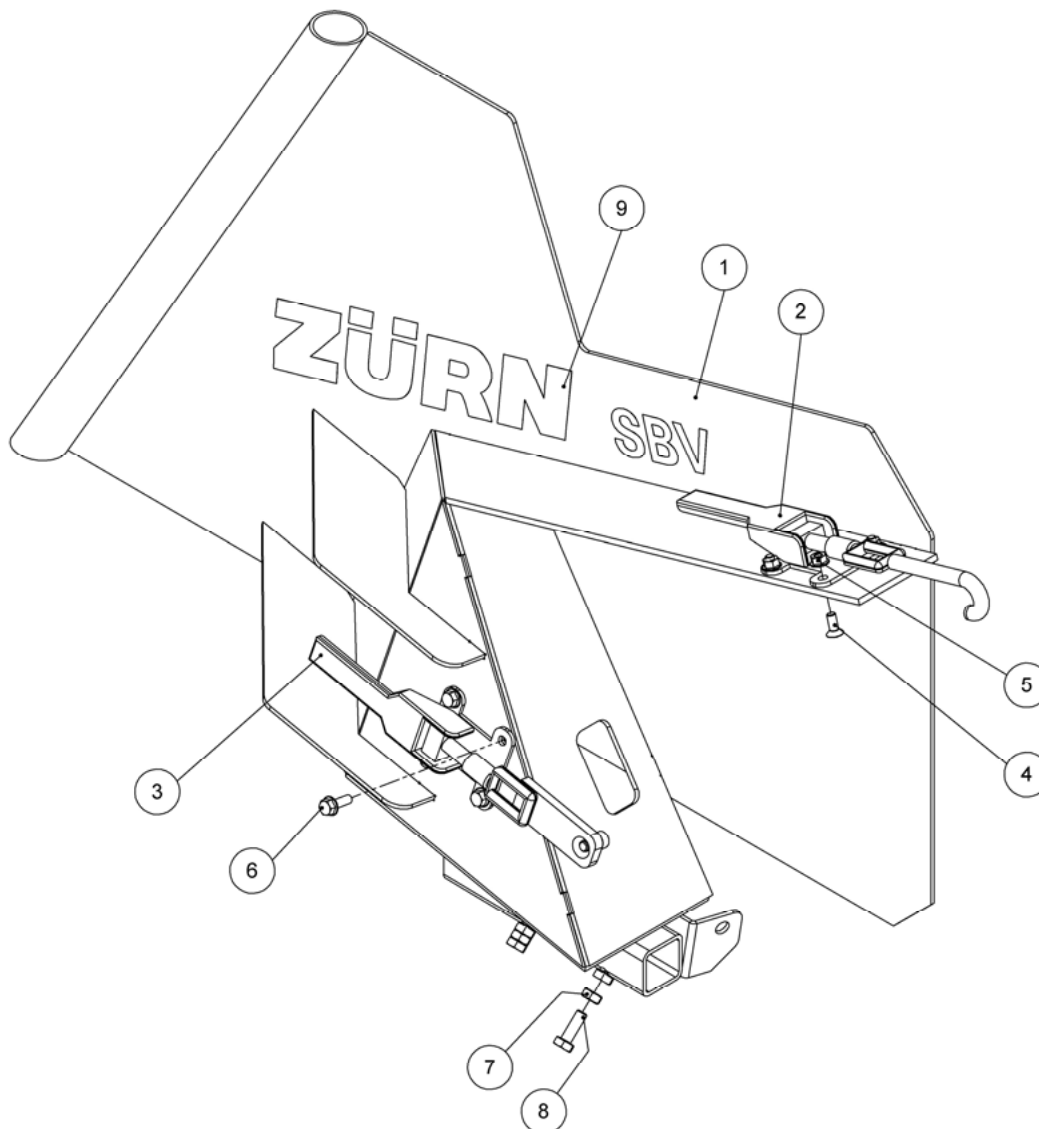

Item	Quantity	Item no.	Designation	Description
1	1	40469	Side plate assembly, right side	
2	1	16126	Hook operating toggle clamp	
3	1	16127	Toggle clamp plate	
4	4	70692	Countersunk bolt	DIN 7991 M8x25
5	8	70005	Hex nut with flange	DIN 6923 M8
6	4	093230	Hex nut with flange	DIN 6921 M8x25
7	2	70015	Hex nut	DIN 934 - M10
8	2	70061	Hex bolt	DIN 933 - M10x30
9	1	41056	Zürn SBV Decale	
1-9	1	40465	Side plate assembly, left side	

Parts list

Supporting arms and bars

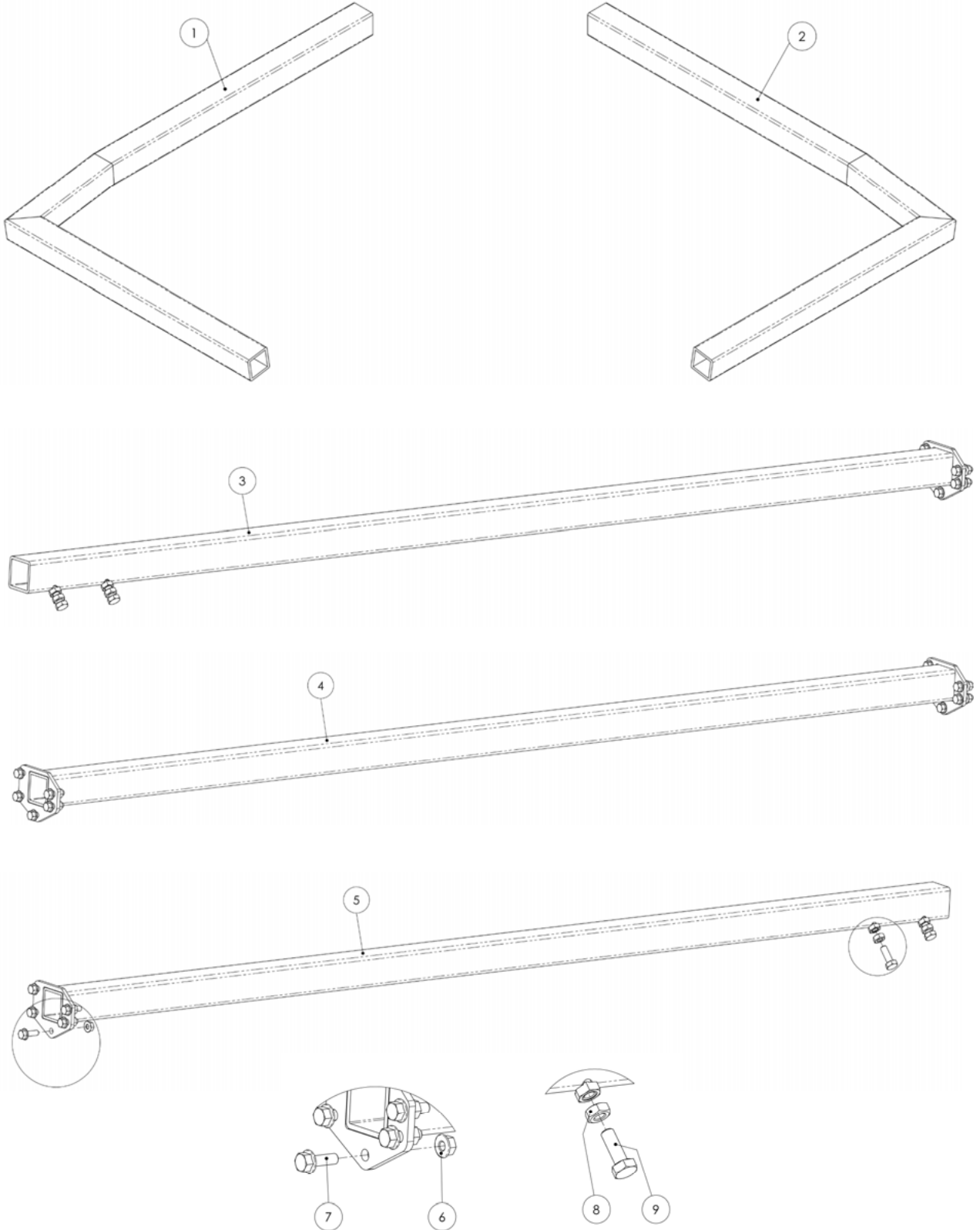

Parts list

Supporting arms and bars

Item	Quantity	Item no.	Designation	Description
1	1	40477	Left supporting arm	
2	1	40478	Right supporting arm	
3	1	40019	Assembled supporting bar, left side	1780mm
4	AR	40018	Assembled supporting bar, central section	1828.8mm
5	1	40020	Assembled supporting bar, right side	1137mm
	1	40021	Assembled supporting bar, right side	603mm
	1	40022	Assembled supporting bar, right side	223mm
	1	40023	Assembled supporting bar, right side	1517mm
	1	40030	Assembled supporting bar, right side	1780mm
6	AR	093230	Hex bolt with flange	DIN6921 M8x25
7	AR	70005	Hex nut with flange	DIN6923 M8
8	4	70015	Hex nut	DIN 934 M10
9	4	70061	Hex bolt	DIN 933 M10x30

Parts list

Supporting bars

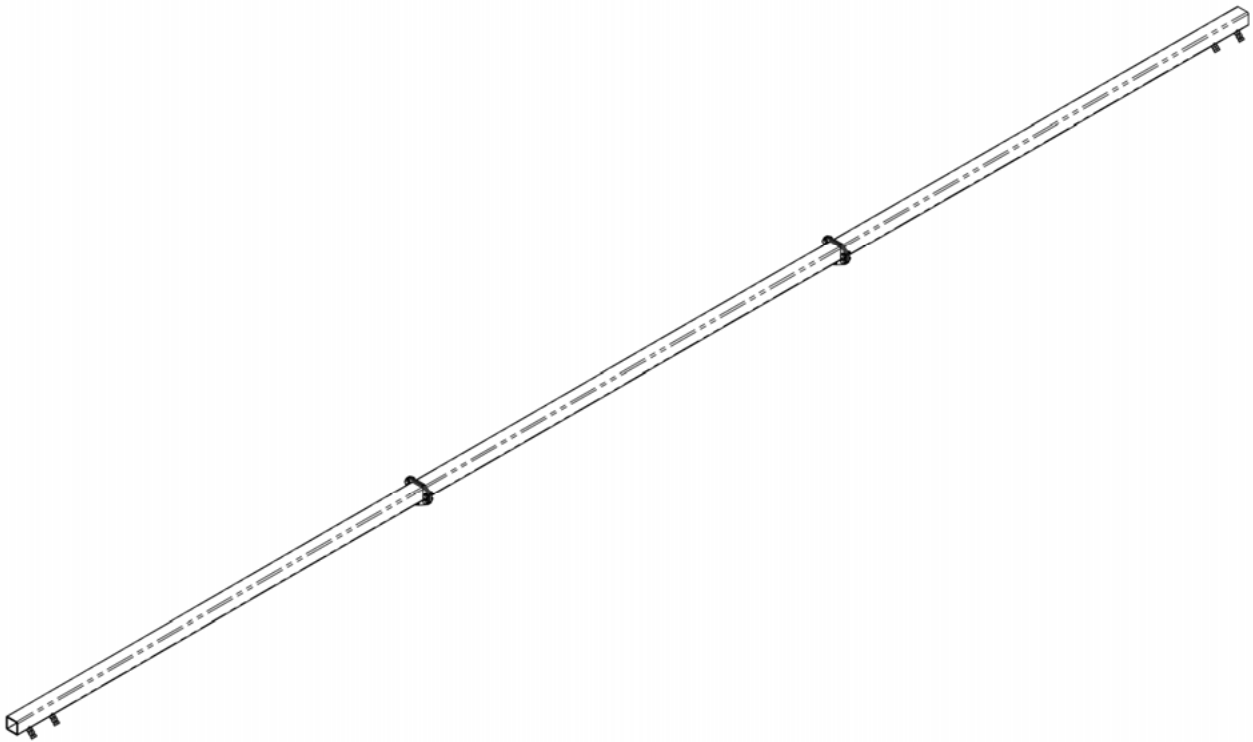

Parts list

Supporting bars

Type	Quantity	Item no.	Designation	Description
618PF 5.50m	1	40019	Assembled supporting bar, left side	
	1	40018	Assembled supporting bar, middle section	
	1	40030	Assembled supporting bar, right side	
	10	093230	Hex bolt with flange	DIN 6921 M8x25
	10	70005	Hex nut with flange	DIN 6923 M8
620PF 6.10m	1	40019	Assembled supporting bar, left side	
	2	40018	Assembled supporting bar, middle section	
	1	40021	Assembled supporting bar, right side	
	15	093230	Hex bolt with flange	DIN 6921 M8x25
	15	70005	Hex nut with flange	DIN 6923 M8
622PF 6.70m	1	40019	Assembled supporting bar, left side	
	2	40018	Assembled supporting bar, middle section	
	1	40020	Assembled supporting bar, right side	
	15	093230	Hex bolt with flange	DIN 6921 M8x25
	15	70005	Hex nut with flange	DIN 6923 M8
625PF 7.60m	1	40019	Assembled supporting bar, left side	
	3	40018	Assembled supporting bar, middle section	
	1	40022	Assembled supporting bar, right side	
	20	093230	Hex bolt with flange	DIN 6921 M8x25
	20	70005	Hex nut with flange	DIN 6923 M8
630PF 9.15m	1	40019	Assembled supporting bar, left side	
	3	40018	Assembled supporting bar, middle section	
	1	40030	Assembled supporting bar, right side	
	20	093230	Hex bolt with flange	DIN 6921 M8x25
	20	70005	Hex nut with flange	DIN 6923 M8
635PF 10.50m	1	40019	Assembled supporting bar, left side	
	4	40018	Assembled supporting bar, middle section	
	1	40023	Assembled supporting bar, right side	
	25	093230	Hex bolt with flange	DIN 6921 M8x25
	25	70005	Hex nut with flange	DIN 6923 M8

Parts list

Reel boards

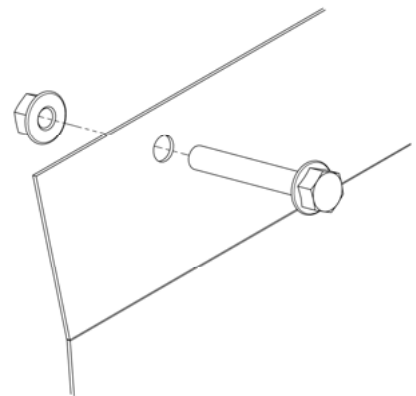
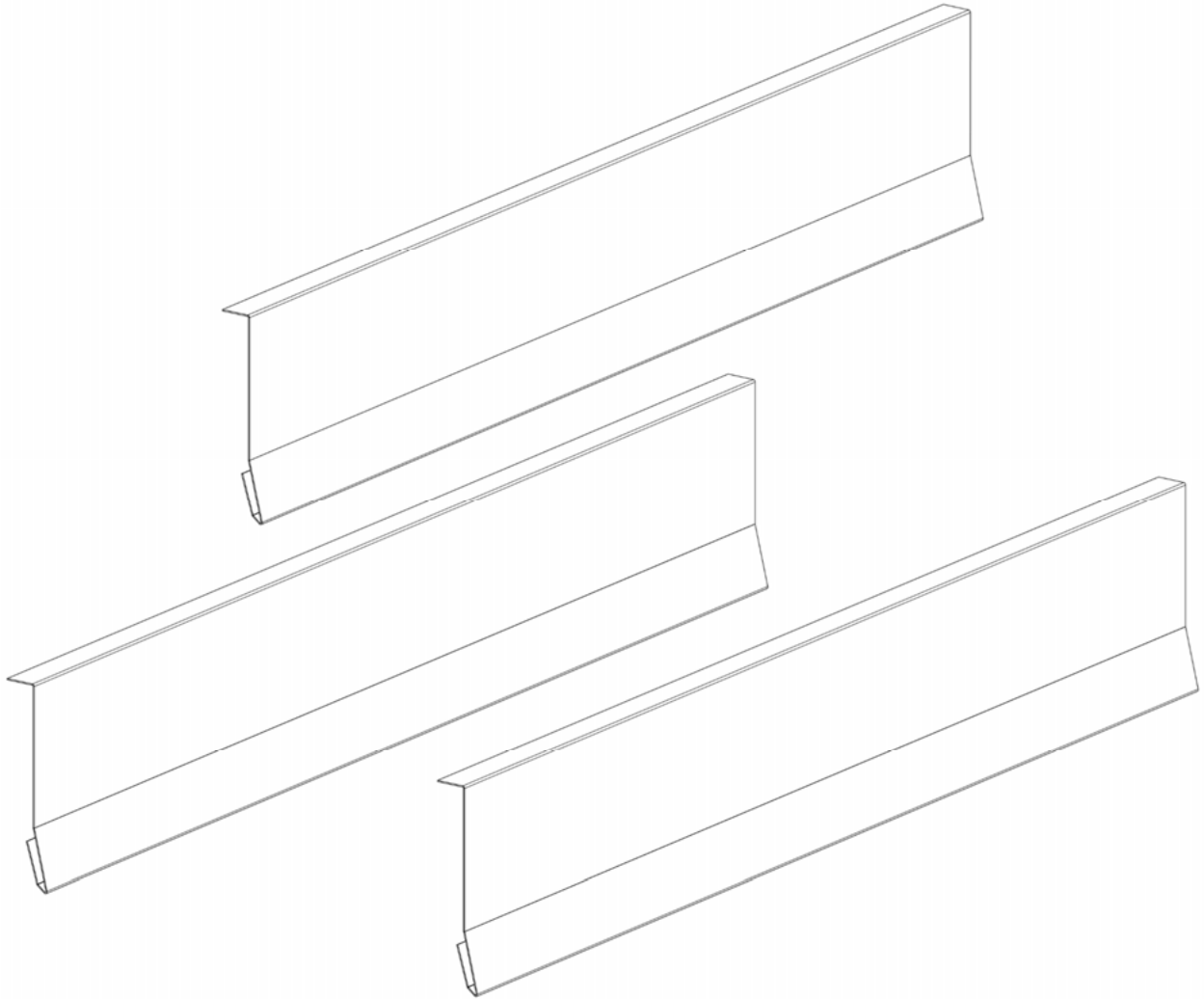

Parts list

Reel boards

Type	Header width	Item no.	Length	Quantity
618PF	5.50m	40078	1070mm	3
		40079	1120mm	3
		40080	1400mm	6
		093819	Hex bolt with flange DIN 6921 - M8x55	24
		70005	Hex nut with flange DIN 6923 - M8	48
620PF	6.10m	40081	1370mm	3
		40080	1400mm	9
		093819	Hex bolt with flange DIN 6921 - M8x55	24
		70005	Hex nut with flange DIN 6923 - M8	48
622PF	6.70m	40082	980mm	3
		40083	1040mm	3
		40075	1320mm	3
		40080	1400mm	6
		093819	Hex bolt with flange DIN 6921 - M8x55	30
		70005	Hex nut with flange DIN 6923 - M8	60
625PF	7.60m	40075	1320mm	3
		40080	1400mm	6
		40084	1450mm	6
		093819	Hex bolt with flange DIN 6921 - M8x55	30
		70005	Hex nut with flange DIN 6923 - M8	60
630PF	9.15m	40080	1400mm	12
		40084	1450mm	6
		093819	Hex bolt with flange DIN 6921 - M8x55	36
		70005	Hex nut with flange DIN 6923 - M8	72
635PF	10.50m	40126	1475mm	15
		40127	1290mm	6
		093819	Hex bolt with flange DIN 6921 - M8x55	42
		70005	Hex nut with flange DIN 6923 - M8	84

Parts list

Central pan

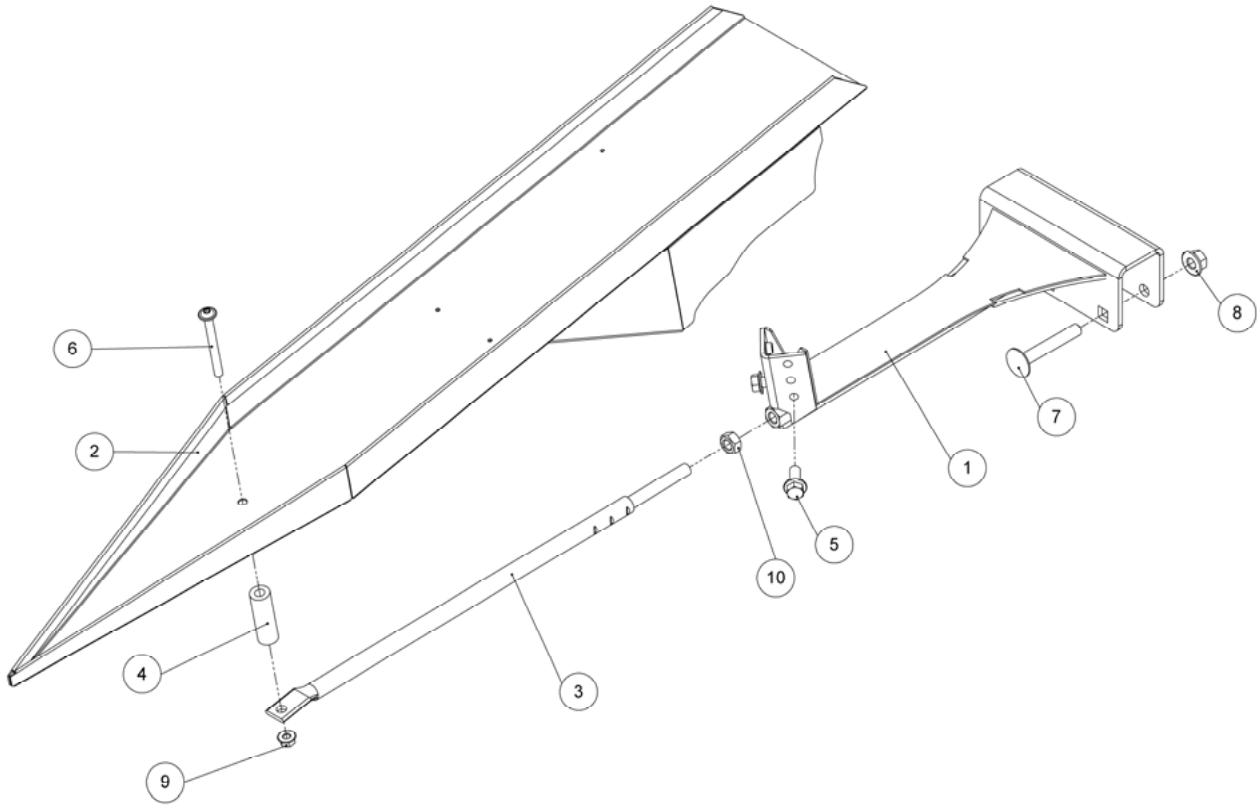

Pos.	Quantity	Item no.	Designation	Description
1	1	40004	Central pan support	Universal
2	1	41110	Central pan	Premium Flow
3	1	40047	Central support stay	
4	1	41138	Distance tube	Premium Flow 600/700
5	2	093223	Hex bolt with flange	DIN 6921 M10x25
6	1	092048	Button head bolt	ISO 7380-2 M8x80
7	2	70199	Lock screw	similar DIN 603 M12x80
8	2	70012	Hex nut with flange	DIN 6923 M12
9	3	70005	Hex nut with flange	DIN 6923 M8
10	1	091664	Hex nut	DIN 934 M12

Pos	Item no	18 ft	20 ft	22 ft	25 ft	30 ft	35 ft	Designation
1-11	41113	22	25	27	31	38	45	Central pan assy complete

Parts list

Outboard pans left hand and right hand

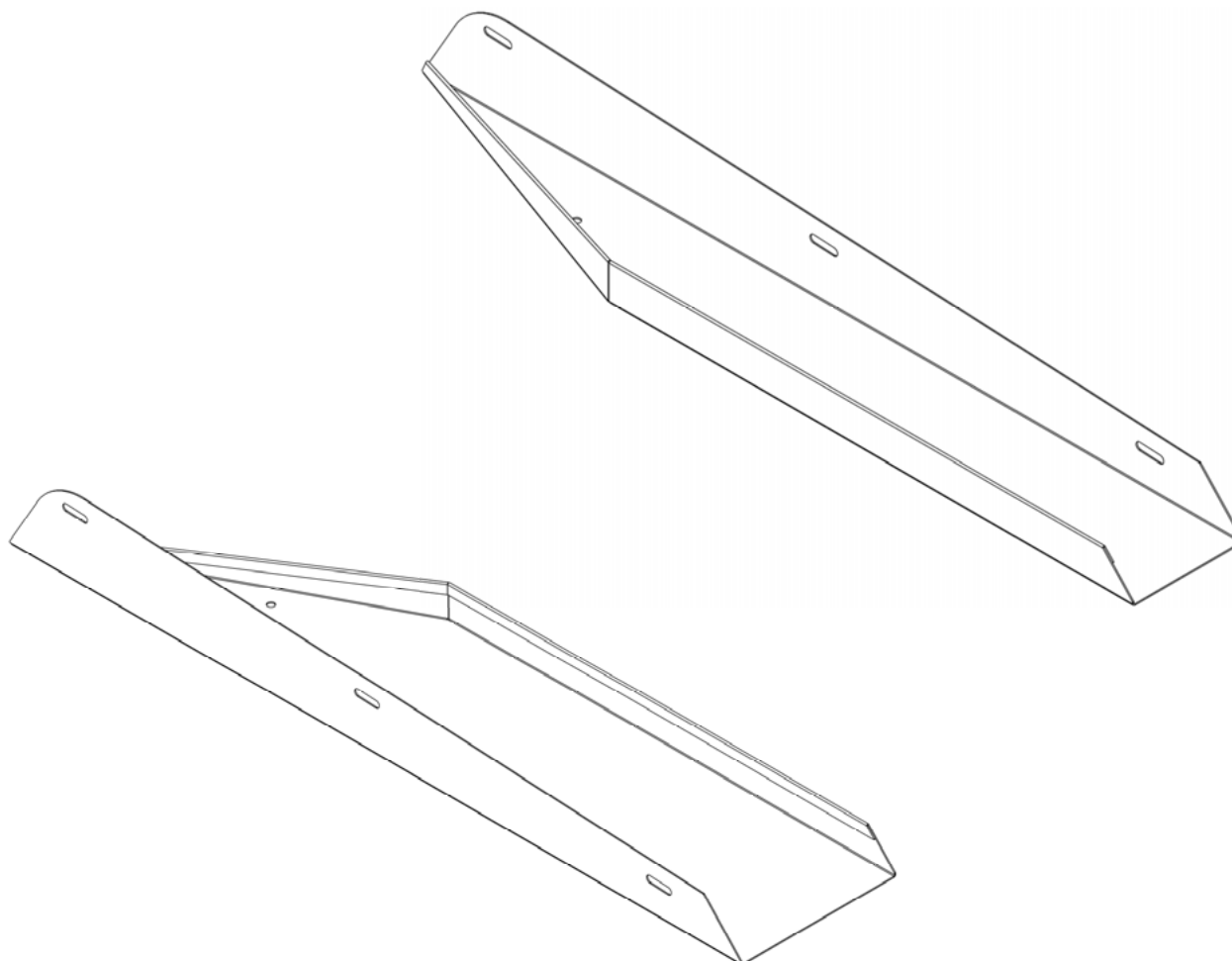

Pos.	Quant.	Item no.	Designation	Description
1	1	40062	Pan 2 finger	Left hand – 145 mm
	1	40058	Pan 3 finger	Left hand – 212 mm
	1	40065	Pan 2 finger	Right hand – 135 mm
	1	40060	Pan 3 Finger	Right hand – 212 mm

Pos	Item no.	18 ft	20 ft	22 ft	25 ft	30 ft	35 ft	Description
1	40062		1				1	Pan 2 finger left hand
	40058	1		1	1	1		Pan 3 finger left hand
	40065	1	1			1	1	Pan 2 finger right hand
	40060			1	1			Pan 3 finger right hand

Parts list

Accessories – Premium Flow 600

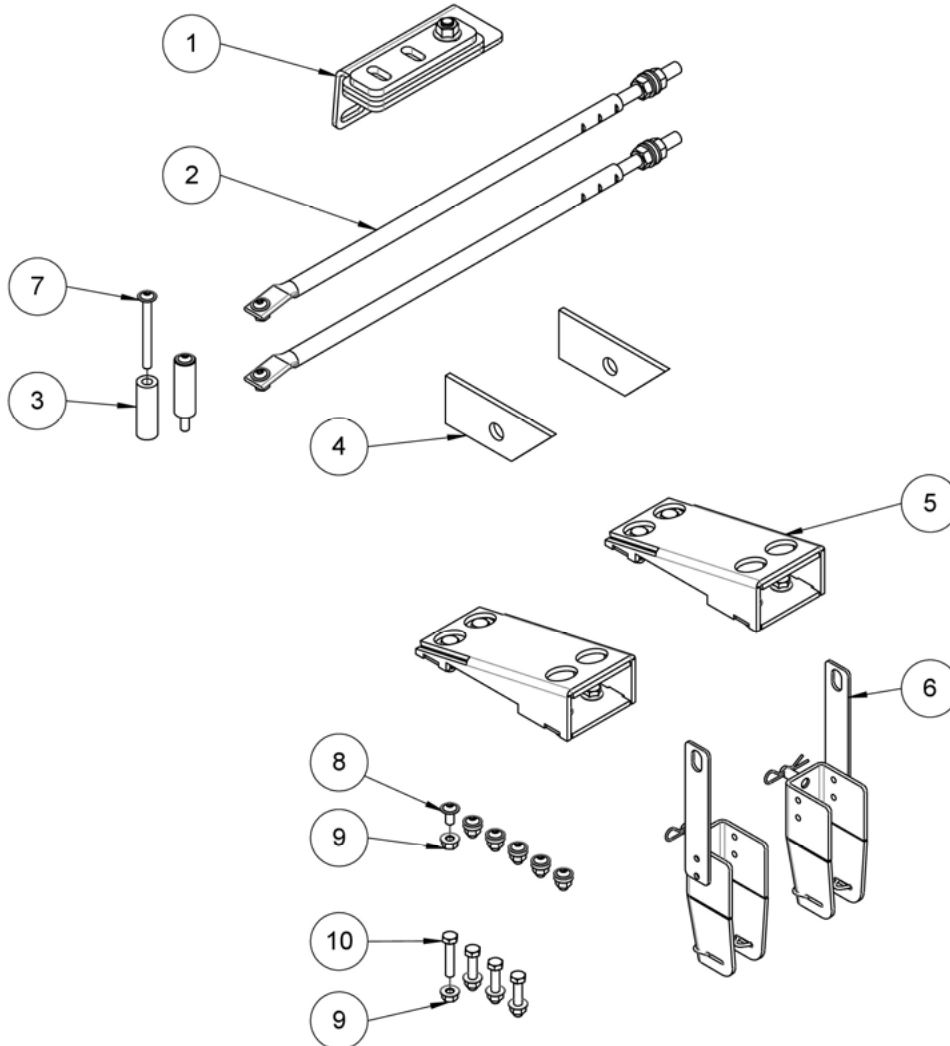

Pos.	Quant.	Item no.	Designation	Description
1	1	41128	Central support complete – Assy Premium Flow 600	Accessories 18 – 20 ft *
	2			Accessories 22 – 30 ft *
	3			Accessories 35 ft *
2	2	40374	Central support stay complete	Assy – L=560 mm
3	2	41138	Distance tube for central support stay	PF 600-700
4	2	40227	Welding latch	Premium Flow 600
5	2	40262	Toggle hook bracket	See page 56
6	1	16165	Reel support set	See page 57
7	2	092048	Button head bolt	ISO 73808/2 – M8x80
8	6	70031	Button head bolt	ISO 73808/2 – M8x16
9	10	70005	Hex nut with flange	DIN 6923 – M8
10	4	70106	Hex bolt	DIN 933 – M8x40

*see page 55

Parts list

Accessories - central support

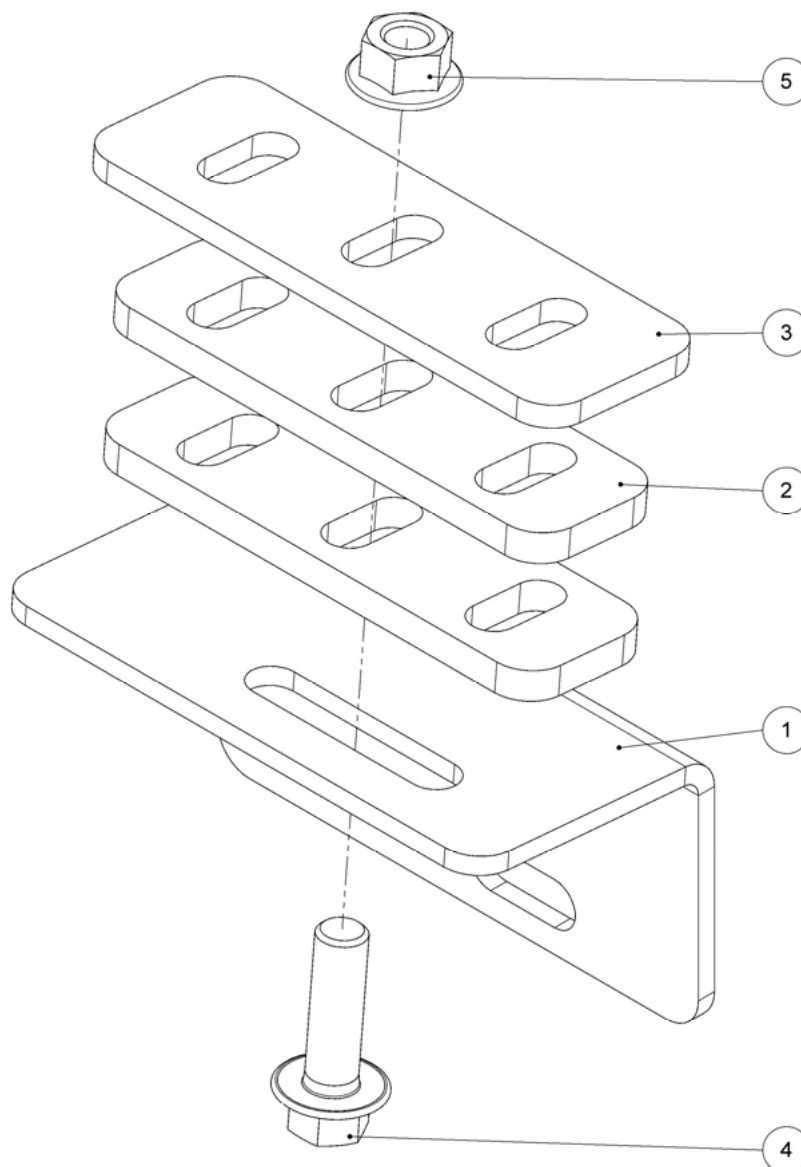

Item	Quantity	Item no.	Designation	Technical information
1	1	40228	Central support mounting angle	
2	2	40272	Spacer plate	
3	1	40229	Weld plate	
4	1	093117	Serrated flange bolt	Similar to DIN 6921 - M12x40
5	1	70012	Hex nut with flange	DIN 6923 - M12

Item	Item no:	PF618	PF620	PF622	PF625	PF630	PF635
1-3	-	1	1	2	2	2	3

Parts list

Accessories - bracket

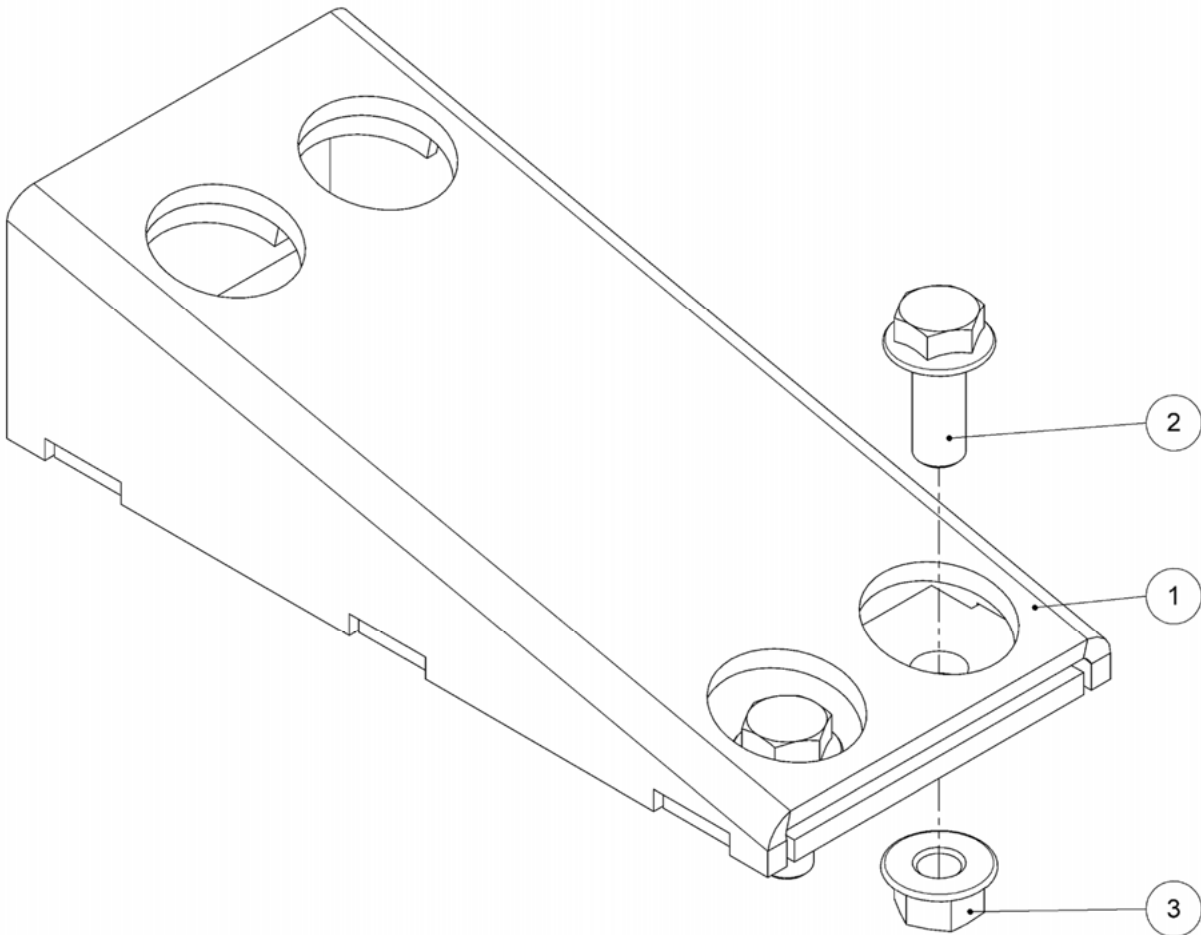

Item	Quantity	Item no.	Designation	Technical information
1	1	40286	Screw-on stand assembly	
2	4	70047	Serrated flange bolt	Similar to DIN 6921 M10x25
3	4	70006	Hex nut with flange	DIN 6923 - M10

Item	Item no:	PF618	PF620	PF622	PF625	PF630	PF635
1-3	-	2	2	2	2	2	2

Parts list

Accessories - reel support set

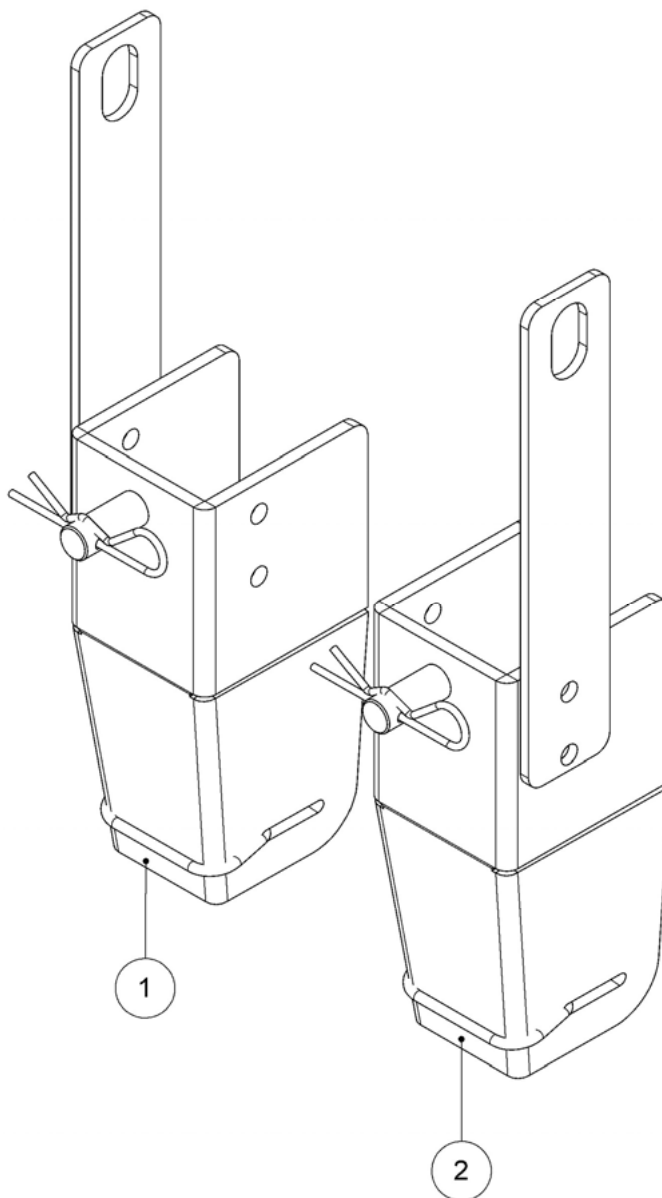

Item	Quantity	Item no.	Designation	Technical information
1	1	16981	Reel support, left side	John Deere 600R
2	1	16982	Reel support, right side	John Deere 600R
1-2	-	16165	Set of reel supports (from 2007)	John Deere 600R

Item	615R	616R	618R	620R	622R	625R	630R	635R
1-2	1	1	1	1	1	1	1	1

Torques for Metric Bolts

Bolts	Grade 4.8				Grade 8.8 oder 9.8				Grade 10.9				Grade 12.9			
	Oiled		Dry		Oiled		Dry		Oiled		Dry		Oiled		Dry	
Size	N•m	lb-in	N•m	lb-in	N•m	lb-in	N•m	lb-in	N•m	lb-in	N•m	lb-in	N•m	lb-in	N•m	lb-in
M6	4,7	42	6	53	8,9	79	11,3	100	13	115	16,5	146	15,5	137	19,5	172
M8	11,5	102	14,5	128	22	194	27,5	243	32	23,5	40	29,5	37	27,5	47	35
M10	23	204	29	21	43	32	55	40	63	46	80	59	75	55	95	70
M12	40	29,5	50	37	75	55	95	70	110	80	140	105	130	95	165	120
M14	63	46	80	59	120	88	150	110	175	130	220	165	205	150	260	190
M16	100	74	125	92	190	140	240	175	275	200	350	255	320	235	400	300
M18	135	100	170	125	265	195	330	245	375	275	475	350	440	325	560	410
M20	190	140	245	180	375	275	475	350	530	390	675	500	625	460	790	580
M22	265	195	330	245	510	375	650	480	725	535	920	680	850	625	1080	800
M24	330	245	425	315	650	80	820	600	920	680	1150	850	1080	800	1350	1000
M27	490	360	625	460	950	700	1200	885	1350	1000	1700	1250	1580	1160	2000	1475
M30	660	490	850	625	1290	950	1630	1200	1850	1350	2300	1700	2140	1580	2700	2000
M33	900	665	1150	850	1750	1300	2200	1625	2500	1850	3150	2325	2900	2150	3700	2730
M36	1150	850	1450	1075	2250	1650	2850	2100	3200	2350	4050	3000	3750	2770	4750	3500
<p>The tightening torques given are guideline values. Do NOT use these values if a different torque or another securing method is specified for a specific application. For stainless steel bolts and nuts for stirrup bolts, see specific instructions. Tighten locking nuts with plastic insert or edge-raised steel locking nuts to the corresponding torque for dry bolts and nuts given in the table unless otherwise instructed.</p>								<p>Shear pins are designed to break at a certain load. When replacing shear pins, use only pins of the same grade. When replacing bolts and nuts, make sure that equivalent parts of the same or a higher grade are used. Tighten higher-grade nuts and bolts to the same torque as the originally used parts. Make sure that the thread is clean and the bolts correctly fitted. If possible, oil normal and galvanised nuts and bolts (except for locking nuts and wheel studs or nuts) unless specified otherwise for the specific application.</p>								
<p>“Oiled” means that a lubricant, such as engine oil, is applied to the bolts or that phosphatized or oiled bolts with a size from M20 are used.</p>																
<p>“Dry” means the use of normal or galvanised bolts without lubrication or bolts with a size between M6 and M18 that are zinc-coated.</p>																

General terms of guarantee

Zürn Harvesting GmbH & Co. KG, Kapellenstraße 1, D-74214 Schöntal-Westernhausen (hereinafter “Zürn Harvesting”) hereby certifies for each customer who has purchased a new Zürn Harvesting machine from an authorised dealer that the materials and workmanship of this machine are guaranteed under the conditions specified below, providing that the machine is put into operation and maintained in accordance with the specifications in the operating instructions.

I. Duration of the guarantee

The guarantee period is one year from delivery of the machine by Zürn Harvesting and is valid for up to 500 operating hours within this period. The replacement of individual parts or repair will not prolong the above guarantee period for the machine.

II. Scope of the guarantee

The guarantee embraces only the reimbursement or repair of the parts and reimbursement of work time required in order to effect the repair, based on the repair times allowed by Zürn Harvesting, under the prerequisite that the fault was determined by our technical customer service department and was acknowledged by Zürn Harvesting to be attributable to faulty materials or workmanship. Replaced parts will become the property of Zürn Harvesting. The customer must allow services received from the vendor/dealer under warranty to be credited to the guarantee.

The guarantee does not cover any further claims against Zürn Harvesting. This means in particular that travel and transport costs will not be reimbursed, nor will Zürn Harvesting be liable for consequential damage, such as loss of harvest or losses of income.

III. Limitations of the guarantee

The guarantee does not apply to defects or faults that are attributable to:

- usual wear and tear;
- failure to heed operating, storage or transport instructions contained in the operating manual;
- use other than as intended, inadequate maintenance, inexpert operation or excessive use;
- damage caused to the machine or its equipment caused during transportation or loading; machines, equipment and parts are shipped at the risk of the recipient;
- external influences on the machine, e.g. third-party damage, weathering or other natural occurrences;
- circumstances that were known to the buyer at the time of purchase.

The guarantee will be rendered null and void if technical modifications are made to the machine without the written consent of Zürn Harvesting or if spare parts other than original Zürn Harvesting spare parts are installed and/or if repairs were not carried out by an authorised dealer. The guarantee is likewise voided if the machine was not put into service for the first time by the dealer in accordance with the instructions of Zürn Harvesting.

General terms of guarantee

IV. Assertion of the guarantee

The terms of the guarantee are dependent upon precise observance of the following regulations by both the dealer and the purchaser:

- The guarantee card (machine card) completed by the dealer and customer must be returned to Zürn Harvesting by post or e-mail as soon as the machine has been delivered to the customer.
- Applications for guarantee claims must be formulated on the corresponding Zürn Harvesting form and presented to Zürn Harvesting by the dealer within one calendar month of discovery of the defect/fault.
- The application must be completed legibly and must contain the following information:
 - Name, address and dealer customer number
 - Name and address of the purchaser
 - Exact machine type and designation
 - Complete serial number of the machine
 - Date of delivery to the dealer and to the purchaser
 - Date of the claim
 - Number of operating hours or acreage harvested by the machine
 - Exact description of the damage and information regarding the probable cause
 - Quantity, item numbers and description of damaged parts

The parts reported as damaged must be returned to Zürn Harvesting free of charge for appraisal, complete with a copy of the guarantee claim application. Any costs incurred for returning the parts replaced or repaired will be borne by the sender.

If the guarantee claim application is refused, the dealer or the customer has a period of 15 days, starting from the day the Zürn Harvesting decision was received, to demand return of the damaged parts. Once this period has elapsed, the parts will be disposed of.

V. Additional clauses

Claims under the guarantee may not be transferred to third parties without the prior, written consent of Zürn Harvesting.

The dealer has neither the right nor the authority to make declarations or to enter into a commitment etc., whether express or implied, in the name of Zürn Harvesting.

The technical support for repair of the machine given by Zürn Harvesting or their representatives excludes any further liability whatsoever by Zürn Harvesting and has no influence whatsoever on the existing terms of guarantee.

Zürn Harvesting reserves the right to modify the design of the machine without prior notice. It is not obliged to transfer such modifications to machines which have already been sold or are in use.

Furthermore, due to the rapid development of the state of the art, no guarantee can be given for the machine descriptions contained in these operating instructions or other technical leaflets and data sheets.

EG- Konformitätserklärung

EG- Konformitätserklärung nach Maschinenrichtlinie 2006/42/EG

Bitte sorgfältig aufbewahren, jedoch nicht im Fahrzeug

EU CERTIFICATE OF CONFORMITY According to Machinery Directive 2006/42/EG

Please keep safely, not inside the vehicle

Hiermit bestätigt die <i>Hereby declares</i>	Zürn Harvesting GmbH & Co. KG	
in alleiniger Verantwortung dass das landwirtschaftliche Anbaugerät <i>the full responsibility for the agricultural implement</i>	Fabrikmarke <i>Brand</i>	Zürn Harvesting GmbH
	Typ <i>Type</i>	SBV
genehmigt in <i>approved in</i>	Schoental	
am <i>on</i>	03.03.2023	
durch den <i>by the</i>	Hersteller / manufacturer	
den grundlegenden Sicherheits- und Gesundheitsanforderungen der Richtlinie 2006/42/EG entspricht. <i>to full fill the complete safety- and health requirements according to machinery directive 2006/42/EG.</i>		
Zur sachgerechten Umsetzung der in den EU- Richtlinien genannten Sicherheits- und Gesundheitsanforderungen wurden folgende Normen herangezogen: <i>For proper implementation according to the EU- Directives for health and safety requirements, the following standards were used:</i>	DIN EN ISO 4254-1 (09/16) DIN EN ISO 4254-7 (12/19)	
Geschehen zu <i>Done at</i>	Schoental	
am <i>on</i>	03/03/23	
	 Rolf Zürn Geschäftsführer, CEO	

Contacts

Ersatzteilbestellung / Spare parts order / Commande des pièces:

Tel.: 0049 (0) 6297 / 92885-27

Fax. 0049 (0) 6297 / 92885-19

E-Mail: parts@zuern.de

Zürn Harvesting GmbH & Co. KG
Eichenstraße 27
D-74747 Ravenstein- Merchingen

Tel.: +49 6297 92885-0
Fax: +49 6297 92885-19
E-Mail: info@zuern.de

Internet: www.zuern.de