

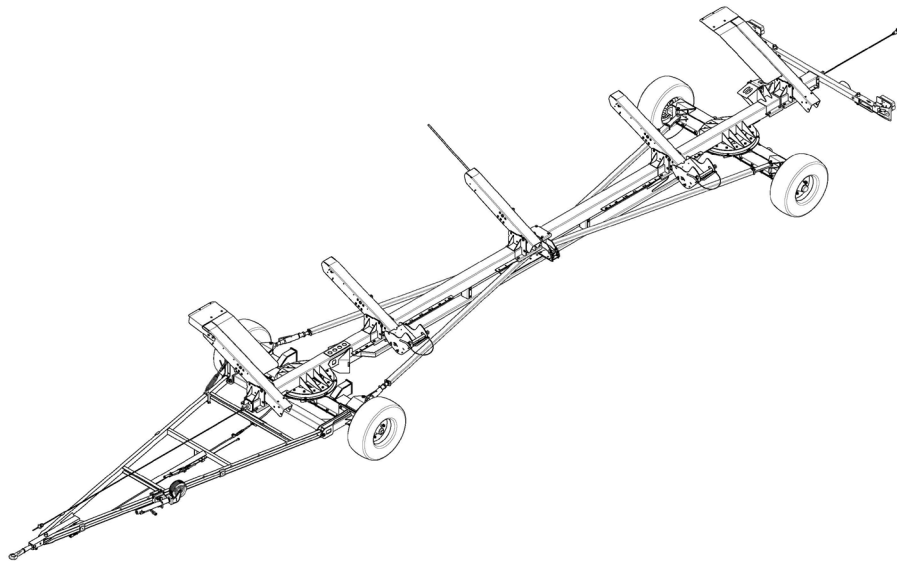

OPERATING MANUAL

SWW X2



2-Axle-Steered
Header Transporter

Masthead

Title: Operating Manual 2-Axle-Steered Header Transporter

Manufacturer: Zürn Harvesting GmbH & Co. KG
Schöntal

Applicable to: SWW-X2

Print number: 35935

2nd issue 2025 (Version B)

Editorial date 01/2025

© Zürn Harvesting GmbH & Co. KG

Author: Matthias Müller

All rights reserved, also applies to the translation.

No part of this operating manual must be reproduced in any form (print, photocopy or any other process) or processed, duplicated or distributed using electronic systems without the written permission of the Zürn Harvesting GmbH & Co. KG, Schöntal.

We reserve the right to make technical amendments.

Printed on paper made from chlorine-free and acid-free bleached pulp.

Foreword

This transporter is designed only for the usual application in agricultural work or similar activities. Any other use beyond this is deemed improper use of the machine. The manufacturer accepts no liability whatsoever for damage resulting from improper use; the risk will be borne solely by the user. Proper use also includes complying with the operation, maintenance and service conditions specified by the manufacturer.

Read this operating manual thoroughly to familiarise yourself with the correct operation and maintenance of the machine and to prevent injuries or damage to the machine. Not doing so can result in injuries or machine damage. This operating manual and the safety labels on the machine may also be available in other languages: please enquire at your dealership.

This operating manual is part of the machine and should be handed over to the purchaser if the machine is re-sold.

Dimensions specified in this operating manual are metric. Use only appropriate parts and bolts. Different spanners are required for metric bolts and bolts with imperial (inch) dimensions.

The designations "left" and "right" are with reference to the forward direction of the machine.

Enter the serial number in the first section of the operating manual. Please record all numbers accurately. In case of theft, these numbers can be important for tracing the machine. Your dealer also needs these numbers when you order spare parts. It is a good idea to keep a second record of these numbers in another location.

Your dealer has carried out an inspection of the machine prior to delivery. A further inspection should be carried out by your dealer after the first 20 to 50 hours of operation in order to ensure the best possible performance for the machine.

This transporter must only be used, serviced and repaired by persons who are familiar with it and who have been briefed about its hazards. The relevant accident prevention regulations and other generally recognized rules and laws for safety, occupational health and road traffic must also be observed. Unauthorized changes to this transporter release the manufacturer from liability for any resulting damage.

Contents

| | |
|-------------------------------------------------------------------|-----------|
| Masthead | 2 |
| Foreword | 3 |
| Contents | 4 |
| Header transporter components | 7 |
| Type Plates | 8 |
| Safety Instructions | 9 |
| Safety instructions for technical staff and operators | 10 |
| Precautions for use and shunting | 11 |
| Precautions for maintenance and repair work | 11 |
| Precautions for travelling on public roads | 12 |
| Modifications to the header transporter | 13 |
| Welding | 13 |
| Using original parts | 13 |
| Bolted assemblies | 14 |
| Waste prevention | 14 |
| Safety decals | 15 |
| Intended use | 17 |
| General rules | 17 |
| Intended use | 18 |
| Limitations of use | 18 |
| Liabilities | 19 |
| Maximum steering angle | 20 |
| Observing the maximum steering angle | 20 |
| Operating the header transporter behind a tractor | 21 |
| Operating the header transporter behind a combine | 22 |
| Instructions for safe use | 24 |
| Scope of Delivery | 25 |
| Assembling the transporter | 26 |
| Condition of the product on delivery | 26 |
| Fitting the wheels | 26 |
| Fitting and setting up the header supports..... | 26 |
| Fitting the lashing rings to the header | 27 |
| Assembling the AM2007 drawbar (SWW-X2)..... | 28 |
| Setting up the brake | 29 |
| Fitting and routing the breakaway cable | 30 |
| Fitting and routing the electric line to the towing vehicle | 30 |
| Operating the header transporter | 32 |
| Securing the load | 32 |
| Special safety measures | 32 |
| Remove the dividers | 33 |
| Remove the crop lifters | 33 |
| Remove the side knives | 33 |
| Fit the cutterbar guard..... | 34 |
| Retract the guide rod..... | 34 |

| | |
|-------------------------------------------------------------------------------|-----------|
| Folding out the lights | 35 |
| The towing vehicle | 36 |
| Attachment to the towing vehicle and uncoupling from the towing vehicle | 36 |
| Connecting the electric line to the towing vehicle | 39 |
| Before operating the header transporter | 40 |
| Forward speed | 41 |
| Placing the header on the transporter | 42 |
| Placing the header on the header transporter | 42 |
| Special header support kits | 44 |
| Securing the load | 46 |
| Securing ZÜRN 700PF headers | 46 |
| Securing John Deere RA / 600R / 600PF headers | 49 |
| Securing John Deere XA / 600X headers | 52 |
| Securing John Deere RDF / 600FD / 700FD headers | 59 |
| Setting up the steering system | 63 |
| Setting up the double-axle steering system | 63 |
| Setting up the braking system | 65 |
| Understanding the overrun brake and the auto reverse system | 65 |
| Components of the overrun braking system (service brake) | 65 |
| How the overrun brake system works | 66 |
| Adjusting the brake pads automatically | 66 |
| The components of the service and parking brake systems (SWW-X2) | 67 |
| Setting up the service brake (SWW-X2) | 69 |
| Checking the configuration of the service brake on the laden machine | 75 |
| Setting up the parking brake (SWW-X2) | 76 |
| Automatic Reversing Mechanism | 78 |
| Function of the reversing mechanism | 78 |
| Parking brake lever | 78 |
| Adjusting the wheel brakes 3006-7 RAZG | 79 |
| Basic setting of the wheel brake | 80 |
| Axle Bearing | 81 |
| Checking the bearing play in the wheel hub | 81 |
| Adjusting the bearing play | 81 |
| Replacing the compact bearings | 82 |
| Wheels | 83 |
| Retighten wheel nuts | 83 |
| Tyres | 84 |
| Tyre pressure | 84 |
| Electrical Installation | 85 |
| Maintenance | 86 |
| General service and maintenance instructions | 86 |
| After the first 10 operating hours | 88 |
| Every 200 operating hours | 88 |
| Every 1000 hours in operation (latest annually) | 89 |
| Lubricants and oils | 90 |
| Grease | 91 |
| Service points | 92 |

| | |
|------------------------------------------------------------------------------------|------------|
| Service points on the drawbar and the front axle | 92 |
| Service points on the rear axle | 95 |
| Torques for Metric Bolts | 97 |
| Malfunctions and Remedies | 98 |
| Technical data | 99 |
| Double-axle-steer header transporters for ZÜRN 700PF headers | 99 |
| Double-axle-steer header transporters for John Deere RA (600R) headers | 99 |
| Double-axle-steer header transporters for John Deere XA (600X) headers | 100 |
| Double-axle-steer header transporters for John Deere RDF (600/700FD) headers | 100 |
| General terms of guarantee | 101 |
| EG- Konformitätserklärung | 103 |

Header transporter components

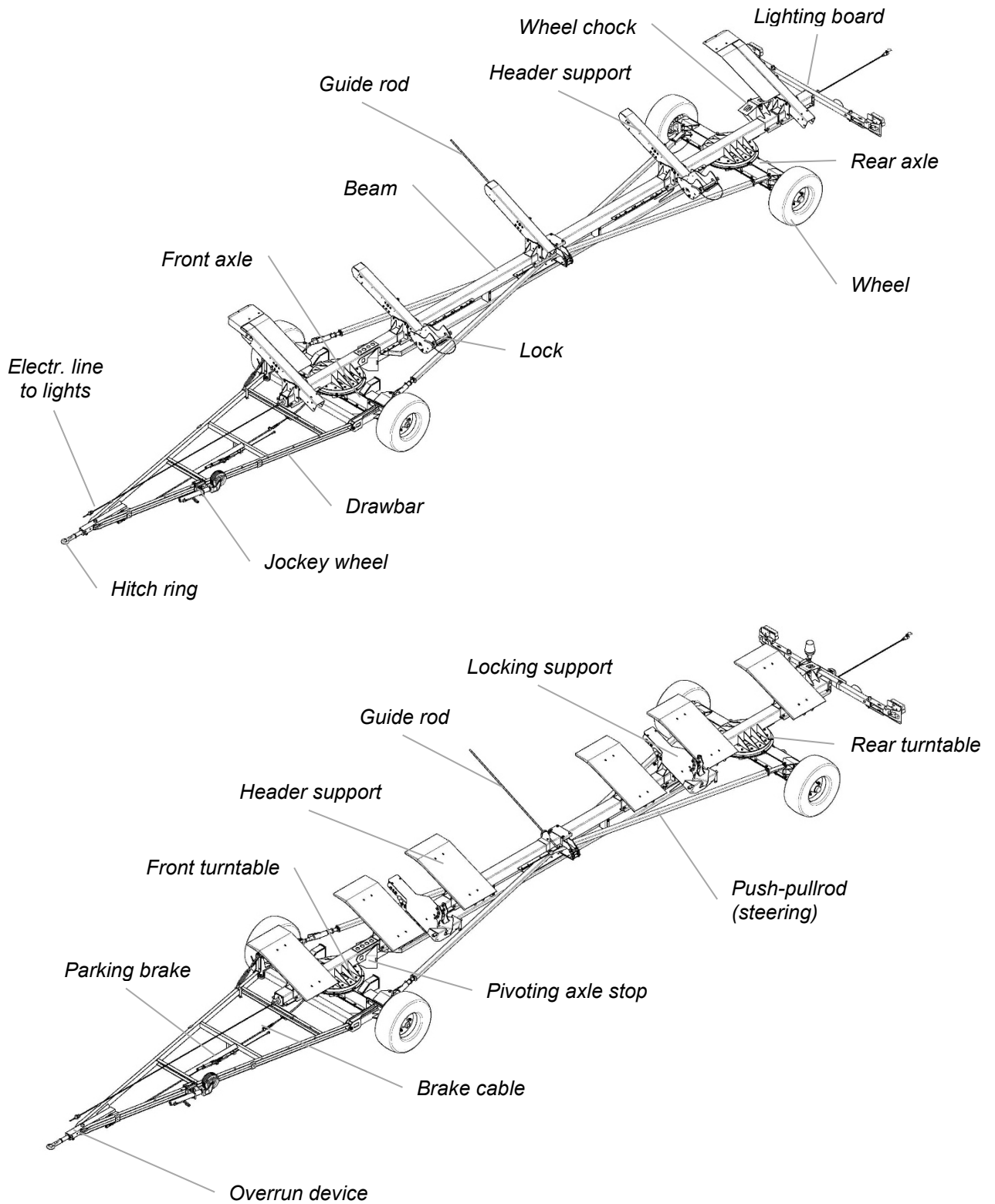

Type Plates

Please make a note of the type designation and serial number of your machine here. This information must be given to the authorised dealer when ordering spare parts or making guarantee enquiries.

Type: _____

Serial number: _____

Chassis number:
(VIN) _____

| ZÜRN HARVESTING | |
|--------------------|----------|
| Typ | _____ |
| Variante | _____ |
| Bezeichnung | _____ |
| Serien-Nr. | _____ |
| Baujahr | _____ |
| Leergewicht | _____ kg |
| zul. Gesamtgew. | _____ kg |
| zul. Achslast vo | _____ kg |
| zul. Achslast hi | _____ kg |
| Stützlast | _____ kg |

Zürn Harvesting GmbH & Co. KG
Kapellenstr. 1
D-74214 Schöntal-Westernhausen
Tel. +49 7943/9105-0

CE

Made in Germany
www.zuern.de

Trailer axle type plate

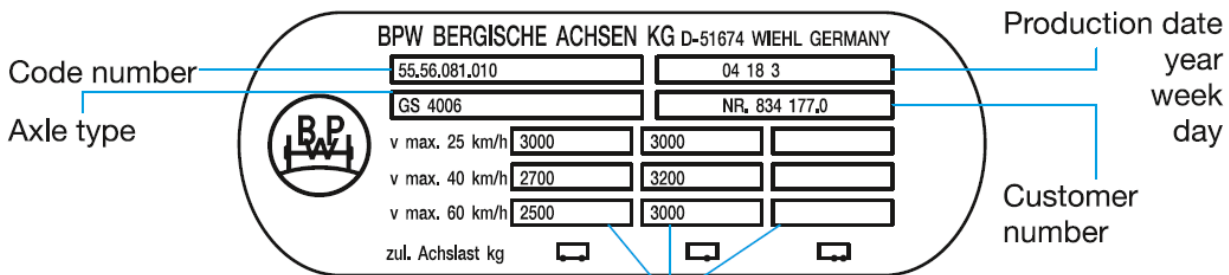

Permitted axle loads, divided into different maximum speeds and design (2-axle vehicle, single axle, tandem)

Braking axle type plate

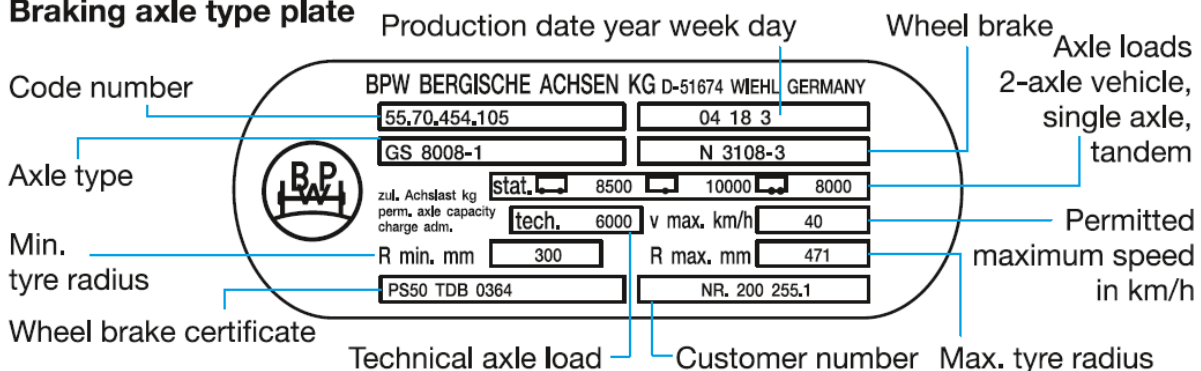

Safety Instructions

Explaining the symbols used in this document

This symbol indicates a potentially hazardous situation which, if not avoided, may lead to personal injury.



This symbol indicates special rules or procedures that need to be observed to avoid machine damage.



This symbol indicates special technical instructions.



The illustrations in this manual are used as examples and may differ from the product. All information and data are subject to change by the manufacturer alone without prior notice.

Safety Instructions

Safety instructions for technical staff and operators

Before using the machine, carefully read and observe all safety rules listed in this manual and observe all decals on the machine.

Before starting work, make sure that you are familiar with all mechanisms and controls and their functions. During operation is too late!

Never leave the machine to anyone who has not been trained in using and operating it properly.

Contact your Zürn sales partner if you have problems understanding certain parts of this manual.

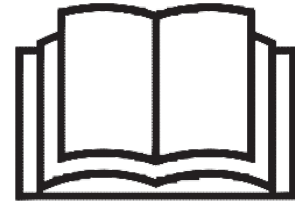

Always apply the handbrake on the header transporter and shut off the engine of the towing vehicle before you work on the transporter. Remove the ignition key and wait until all moving parts have come to a complete stop.

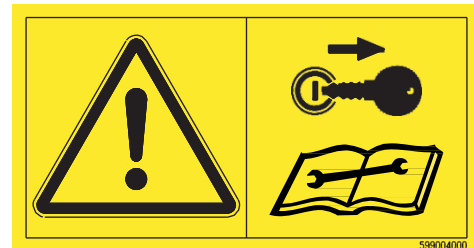

Wear close-fitting clothes! Loose clothing can easily get caught in moving machine parts.

Wear protective gear that suits the work at hand (gloves, footwear, goggles, helmet, ear protectors, etc.).

Any ropes, cables, linkages, etc. of remote-controlled mechanisms must be routed and installed in such a way that they do not cause unintentional machine action leading to accidents and damage. This applies to all transport and working positions.

Before each use verify that nuts and bolts are tight - especially those that attach tools such as blades. Retighten if necessary.

Before you use the machine make sure all safety features and guards are in place, in protective position and operable. Immediately replace any inoperable safety features.



Safety Instructions

Precautions for use and shunting

Before changing over from transport to working position and vice versa, ensure that no persons are within the manoeuvring zone of the machine.

Precautions for maintenance and repair work

Before carrying out any work or intervention on the header transporter, shut off the engine on the towing vehicle, remove the ignition key, wait until all moving parts have come to a complete standstill and apply the parking brake. Depressurise the hydraulic system.

Prop up and secure any machine parts that are raised for maintenance or repair.

Disconnect all electric lines from the towing vehicle before working on the electric system or before welding on the transporter.

Repairs on parts under strain or pressure (springs, accumulators, etc.) must be carried out solely by specialist staff who have the necessary qualification and special tools.

Wear protective gear that suits the work at hand (gloves, footwear, goggles, helmet, ear protectors, etc.).

Do not weld, solder or use flame cutters near pressurised liquids or highly flammable products.

Only use original spare parts to ensure your personal safety and correct functioning of the header transporter.

We strongly recommend to have the machine and its parts and fastening elements checked by your authorised Zürn Harvesting sales partner after each season.



Safety Instructions

Precautions for travelling on public roads

Dimensions

The combination must comply with local requirements relating to maximum dimensions for travel on public roads. In case of doubt, seek information beforehand from the relevant authorities.

If the combination exceeds the maximum dimensions and yet has to be transported on public roads, contact the local authorities to obtain a special permit before you travel on public roads.

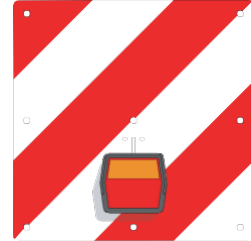

Transport position

Before travelling on public roads, place and secure the machine on a suitable transporter, following the instructions in this manual.

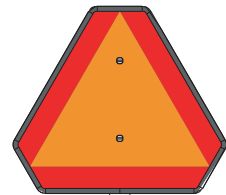

Lights and warning devices

Before travelling on public roads, ensure that all required lights and warning panels are in place.

Check these devices for proper functioning and visibility. Replace any missing or damaged parts immediately.

Maximum speed

Always comply with the current regulations regarding speed limits on public roads.

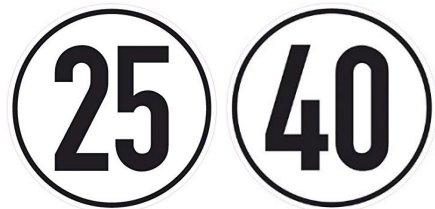

When travelling on public roads, always comply with the relevant regulations.

Before travelling on public roads and before each use check the header transporter and the towing vehicle for road safety and operational safety!



Safety Instructions

Modifications to the header transporter

Any modifications to the transporter and its optional features must be approved in writing by the manufacturer. The warranty and product liability will be voided, if such modifications are carried out without the written approval of the manufacturer.

The manufacturer's liability refers to the original condition in which the vehicle is delivered to the country of destination as contractually agreed by the manufacturer.

Any unauthorised modifications to this transporter render any manufacturer liability for any consequential damage null and void.

Welding

Ensure that any type of welding is carried out by qualified and certified welders. Welding must not affect the warranted properties of the steel structure. This applies in particular to structural parts and to the components that support the load. For this reason, any type of welding on the chassis and axles must be approved in writing by the manufacturer. In case of non-compliance, the manufacturer shall consider the weldment as an unauthorised modification to the transporter.

Using original parts

Only use original parts sourced from the manufacturer. This is mandatory. Using third-party parts voids the manufacturer warranty including for consequential damage resulting from this.

Safety Instructions

Bolted assemblies

Observe the property class when fastening and replacing bolts and nuts (see the table in this manual and the parts list).

After assembling the transporter, tighten all bolts to the proper torque.

For special torques read the assembly instructions or ask the manufacturer.

For any torques of regular bolts refer to the table.

Self-clinching bolts and nuts must be replaced by new ones after they have been removed during a repair.

This is necessary as nuts with a self-clinching fastener lose their holding power with each reuse.

Before selling the vehicle and optional equipment to a third-party country, the seller must seek information on whether an official approval or a safety inspection by an officially recognised testing centre is required before the vehicle can be put into operation in the specific country.

Waste prevention

Never pour environmentally hazardous products (oils, greases, filters, etc.) into a sink or empty them onto the ground or in other spaces. Never burn or throw away used tyres. Have waste disposed of by specialised disposal companies.

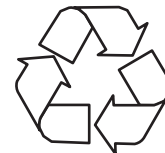

Safety Instructions

Safety decals

Safety decals are placed in various locations on the machine. Always follow these instructions! The decals alert operators to potential hazards and provide rules of practice to cut out any risk of an accident.

Keep the safety decals clean and legible and replace them immediately when damaged, worn or lost.

Operating instructions

The operating instructions contain all the necessary information for the safe use of the machine. To avoid the risk of accidents, read the operating instructions carefully and follow all instructions.

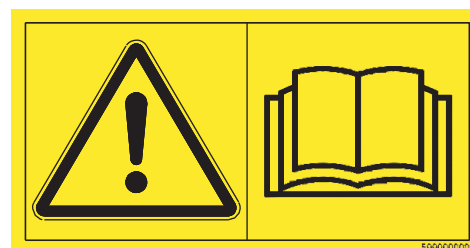

Working on and intervening in the header

Before carrying out any type of work on or intervention in the header, disengage the clutch in the driveline, shut off the engine, remove the ignition key, wait until all moving parts have come to a complete standstill and apply the parking brake.



Parking the transporter

Secure the transporter with a wheel chock before removing it from the towing vehicle or parking it.

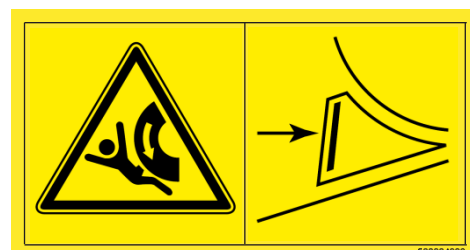

Safety Instructions

Placing the header on the transporter

When placing the header on the transporter, keep clear of the danger zone between the header and the transporter.



The header is lifted

Keep clear of the header swing area when placing it on the transporter.

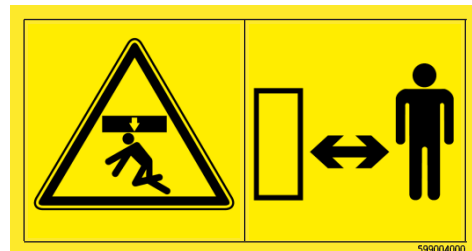

Risk of crushing

Keep clear of the drawbar unit and all steering elements (e.g. turntables, steering rods) while operating the machine. Risk of being crushed at a full lock turn.

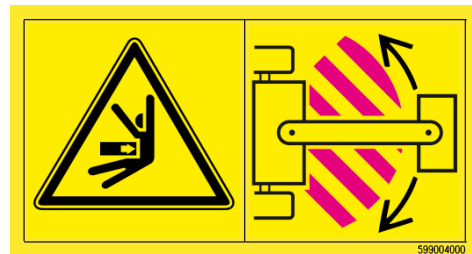

Retighten the wheel bolts

Retighten the nuts after the first journey.

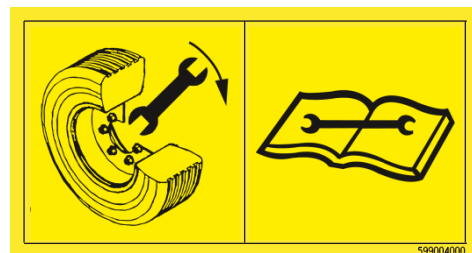

Intended use

This vehicle is intended solely for transporting combine headers behind an agricultural machine such as a tractor or combine harvester. Any other use is considered as not intended. The manufacturer will not be held liable for any damage resulting from applications that are not considered intended use. The risk involved by such unintended use rests solely with the user. The intended use also refers to adhering to the conditions dictated by the manufacturer regarding operation, service and maintenance and repair.

It is absolutely necessary to observe the following instructions. The improper use or non-compliance with the general rules given below will invalidate the warranty and the vehicle approval.



General rules

- Never exceed the permissible gross weight of the machine.
- Never exceed the total vehicle width, length and height.
- Never exceed the permissible brake load.
- Never shift too much weight on one side of the vehicle by overloading it or steering it over kerbs or similar obstacles.
- Do not fit wheels or tyres that are not approved. Ensure the track width is set to maximum.
- Do not expose the machine to excessive stress and strain due to wheel camber and inappropriate offset.
- Never exceed the permissible maximum speed.
- Before each use of the vehicle, ensure that the brakes and brake systems are configured correctly and function trouble free.
- The manufacturer gives no warranty on wear and unauthorised modifications.
- Verify that all lights function properly before each use.

Never exceed the permissible payload and maximum speed of the vehicle!



All important information on the technical data of the vehicle are provided in the registration papers or the vehicle ID document.



Intended use

Intended use

- All Zürn header transporters and all elements used to support and secure a header must be used solely as intended.
- Any other use is considered as not intended. The manufacturer shall not be liable for any damage resulting from this type of use.
- Observe all technical data and do not exceed any maximum limits when operating the header. This applies in particular to the permissible payload, gross weight, axle loads, tongue load and the maximum speed of the vehicle.
- The intended use refers to adhering to the conditions dictated by the manufacturer regarding operation, service and maintenance and repair. The vehicle must be operated, serviced and maintained by staff who received the proper training and instructions and who have been advised of the hazards involved when operating the machine.
- Safe ground speeds during transport on public roads are down to the road gradient and slope, to the weight as well as to the position and centre of gravity of the load, to weather conditions and traffic rules.
- It is absolutely necessary to substantially reduce the ground speed when cornering or travelling in sloping or difficult terrain.
- The towing vehicle must have the capacity to pull and brake the laden header transporter.
- The hitch system of the towing vehicle must be suitable to accommodate the hitch ring of transporter and meet the requirements to pull the combined gross weight of the header transporter and the header itself.
- Never pull the header transporter at speeds that exceed its permissible maximum speed!

The following uses are not considered intended use:

- Using the header transporter to transport loads that are different from that which is specified in this manual.
- Exceeding any of the maximum figures specified in the technical data.
- Having the transporter operated by unauthorised and untrained staff.
- Allowing people to ride on the transporter.

Limitations of use

- The technical data and limits must not be exceeded in any stage of the life cycle of the machine.

Solely operate the vehicle and its optional equipment within its maximum limits and according to its intended use.



Intended use

Liabilities

Owner

The owner is in charge and liable for the following:

- Keep the machine and the elements that support and secure the load in good condition.
- Operate the machine in line with its intended use.
- Forbear carrying out functions and actions that are not in line with the intended use.
- Select the proper staff to assemble, operate and service the machine.
- Train the staff who will assemble, operate and service the transporter, using the complete assembly and operating instructions.
- The manual is made available to operators and service staff in a language that is widely understood in the country.
- Service all service points at the intervals specified in the lubrication plan.
- Document any accidents the transporter may have been involved in.
- Provide workshop staff access to the operating and service and maintenance instructions before and during service and maintenance and repair work.

Operator

Operators are responsible for:

- not being intoxicated when driving.
- not exceeding the maximum speed to which the machine is approved.
- being familiar with the local traffic rules and measures to be taken in an emergency.
- telling the owner if they didn't understand the functions or controls of the machine.
- telling the owner if some functions have failed or if it is not possible to operate the machine safely.

The manufacturer understands that the operator has a driver's license that is valid in the country where the header transporter is operated and that he or she is licensed to operate a combination of such gross weight and length.



Maximum steering angle

Observing the maximum steering angle

Observe the maximum turning angle of the transporter when operating it behind the suitable and homologated tow vehicle.

General

The SWW-X2 header transporter has a mechanical turntable steering system. This type of steering operates both axles from the drawbar assembly. The axles move automatically to the correct angle relative to their current position and to each other.

The maximum turning angle of the Zürn SWW-X2 header transporters is 45°. This is absolutely adequate for all common manoeuvres.

A steering angle stop prevents any further movement beyond 45° so the steering unit (hence the wheels on the axles) cannot move any further. The steering angle stop consists of the elements on the front axle and their welded counterparts on the chassis.

The illustration shows the steering unit at full lock making a left turn. The steering angle stop hits the chassis. The steering unit cannot move any further making a left-hand turn.

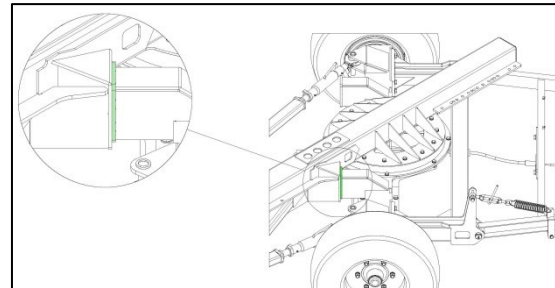
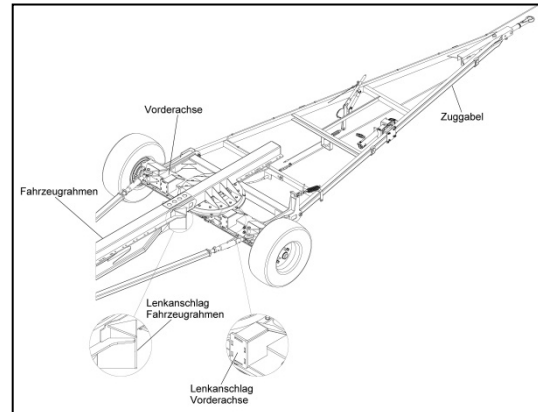

Maximum steering angle

Operating the header transporter behind a tractor

The steering unit on the transporter is at full lock

When the steering unit hits the stop when cornering, do not continue making the turn. Exceeding the turn angle of the steering unit may damage the transporter.

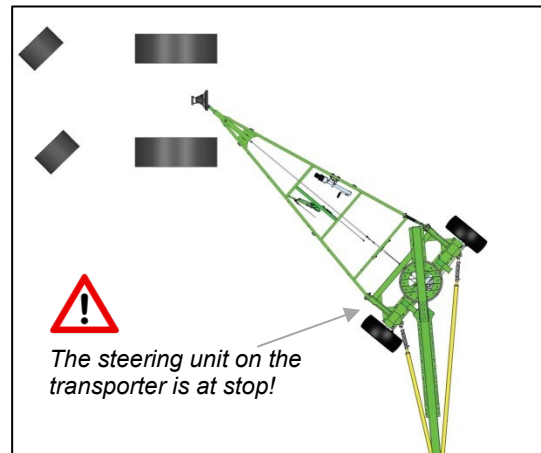

Avoid excessive turn angles

If the operator continues to reduce the turn angle, the drawbar assembly will be turned beyond its full lock position.

Although the drawbar is now at full lock it is exposed to forces that pull it towards the turning circle. This is not permitted!

Exceeding the steering angle may permanently damage the hitch ring shaft. This in turn affects the overrun device and the brake functions of the header transporter so that it can no longer be braked.

Therefore inspect the hitch ring for damage or deformation each time you attach the transporter to the tractor or combine.

Exceeding the steering angle on the laden header transporter in difficult terrain (e.g. heavy and deep soil) may deform the hitch ring permanently and also damage the drawbar.

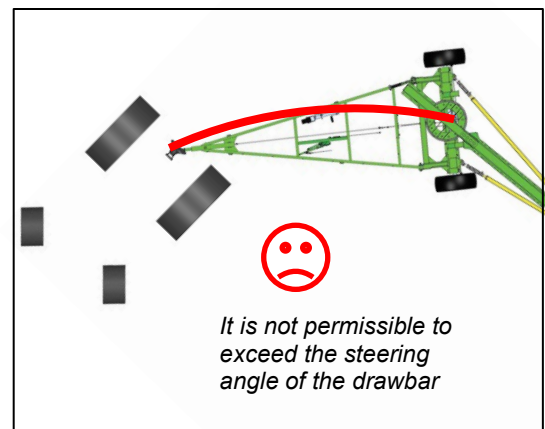

Maximum steering angle

Operating the header transporter behind a combine

Be very careful when pulling the SWW-X2 series transporters with a combine and making turns that may cause the steering system to hit stop.

The combine's rear-axle steering causes the header transporter to behave very differently when travelling around bends than when running behind a tractor. Therefore, we will discuss a steering manoeuvre for a combine-SWW combination that makes an abrupt right turn immediately after making a left hand turn. This is a typical manoeuvre that may cause damage to the drawbar.

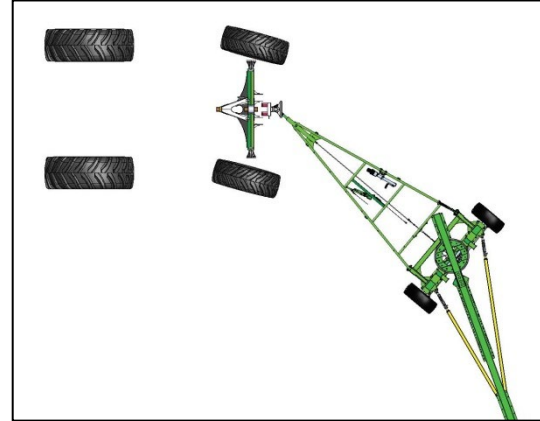

The steering unit is not at full lock. The steering angle stop does not hit the chassis.

The steering unit on the transporter is at full lock

The illustration shows the situation in which the steering unit is at full lock. The front axle is turned to a less than 45° angle and the turn angle stops hit the chassis.

In this situation, avoid by all means making a full lock turn (i.e. continue turning the drawbar assembly to the middle of the curve), because this will risk damaging the drawbar assembly.

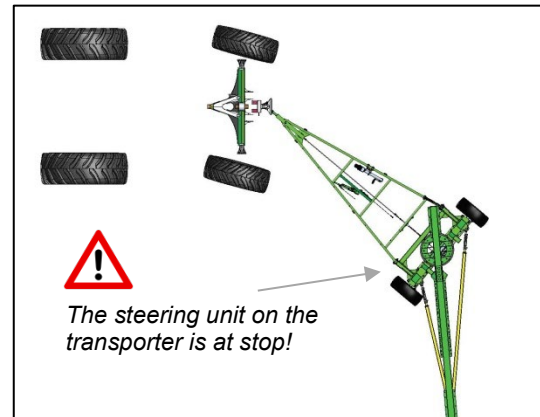

The steering unit on the transporter is at stop!

Maximum steering angle

Lock-to-lock turns

In a lock-to-lock, the combine makes an abrupt right-hand turn from a full left turn.

The combine's rear-axle steering causes the rear end (and the hitch) of the machine to veer to the right. As it does so, the hitch system initially follows suit, leaving the hitch ring swing towards the inside of the left-hand curve. This however increases the strain on the drawbar and its steering unit which is already at stop and full lock.

This may damage the hitch ring and the drawbar and even uncouple the transporter from the combine.

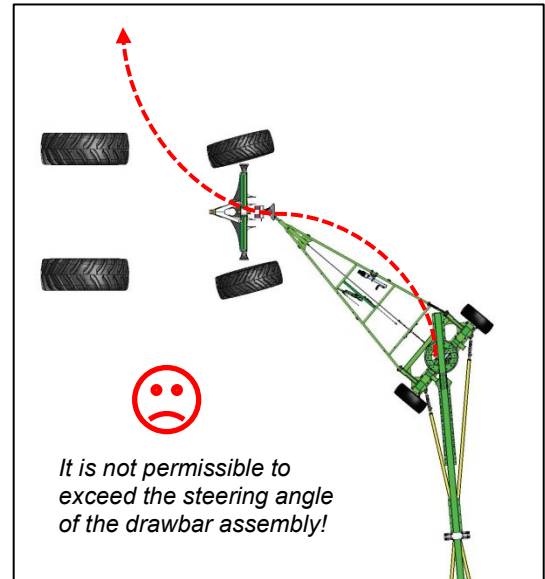

The drawbar assembly is turned through an angle that exceeds its stop position.

Replace a damaged or deformed hitch ring and A-frame. Never repair a deformed hitch ring or A-frame!



The drawbar is a component that requires homologation. When replacing a drawbar, enter the homologation number of the new drawbar in the assessment document of the header transporter.



Maximum steering angle

Instructions for safe use

All drawbar components are specified to regulations that govern the operation of this type of vehicles on public roads.

We explicitly point out that these components are not designed to absorb those high levels of lateral stress and strain that occur in the situations described above. Therefore we will assume no liability and warranty for any damage arising from any manoeuvres described above, because these do not present instances of intended use.

To ensure the safe operation of the Zürn SWW-X2 header transporters, adhere to the following instructions:

- When travelling around bends, avoid turning the drawbar beyond stop.
- When pulling the header transporter with a combine, avoid making a lock-to-lock turn.
- Before steering the combination through an 'S'-line, initially steer the header transporter from its left-hand lock position to straight ahead position. Then, from the straight ahead position make the turn to the opposite side.



Depending on the specification of the combine and the header, the header transporter or its load is at risk of fouling with the combine when this is making an extremely tight turn.

To avoid such a collision remove the dividers from the header.

The operator must verify at any time that the combination is in good transport order.



Scope of Delivery

An operating manual is stored in the document box (A) when the machine is delivered.

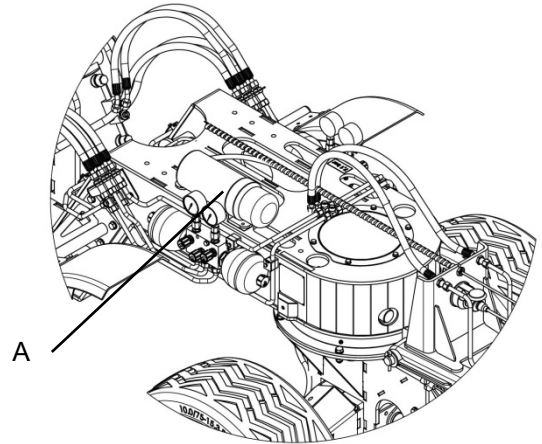

Assembling the transporter

Condition of the product on delivery

For reasons of transportation, the header transporter is delivered by the manufacturer with some components (e.g. drawbar, wheels) not being mounted to the chassis. These are included in the delivery. Yet the header supports are pre-bolted to their mountings on most machines.

Fitting the wheels

The transporter is delivered from the factory with its wheels not attached but included in the delivery. They have to be mounted to the transporter before this can be operated.

The wheels are fitted to the hubs using the wheel nuts and limes-type conical spring washers.

► See section “Wheels” for further instructions on fitting the wheels.

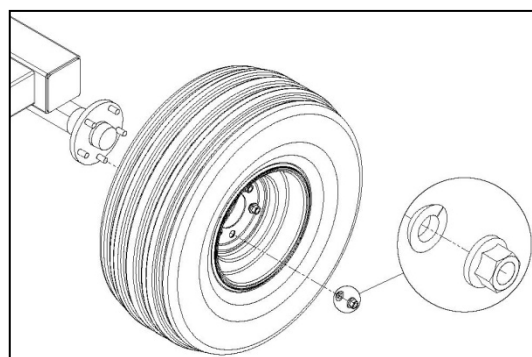

Fitting and setting up the header supports

In factory-fitted condition the mountings for the header supports are bolted in place.

The cargo securing system is tailored to the specific header that the transporter is designed to carry. Therefore, the header supports and their mountings vary depending on the specific header.

Before operating the transporter, bolt the header supports to their mountings. The angle of the header supports is set by adjusting the top links.

► See section “Securing the load” for instructions on configuring the header supports.

Assembling the transporter

Fitting the lashing rings to the header

Fit the lashing rings that are supplied with the transporter to the combine header. They are customised to the specific header model and supplied with the header transporter.

► See section “Securing the load” for instructions on fitting the lashing rings.

Assembling the transporter

Assembling the AM2007 drawbar (SWW-X2)

For reasons of transport length, the double-axle transporters are delivered without the drawbar mounted to them. The drawbar is included in the delivery as a separate package.

Before you can operate the transporter, it is necessary to attach the A-frame and connect the braking system on the drawbar to the transporter.

Attaching the A-frame

Use the two bolts that are supplied with the machine to mount the drawbar to its frame.

When tapping in the spring bolts, make sure that the slide locking bolt faces mate with the appropriate faces on the transporter.

Secure the two bolts with the lock-nuts supplied and secure the lock-nuts with split pins.

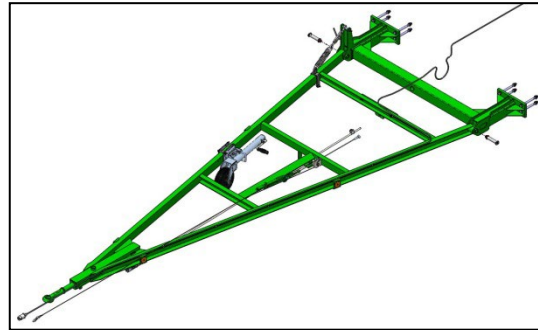

Configuring the drawbar

All drawbars on the double-axle header transporters from Zürn Harvesting are provided with a system that makes sure the drawbar maintains its height.

Connect the coil spring and the turnbuckle (these are attached to the drawbar frame) to the drawbar. You alter the pressure of the coil spring by adjusting the turnbuckle. This also alters the position of the hitch ring relative to the towing vehicle.

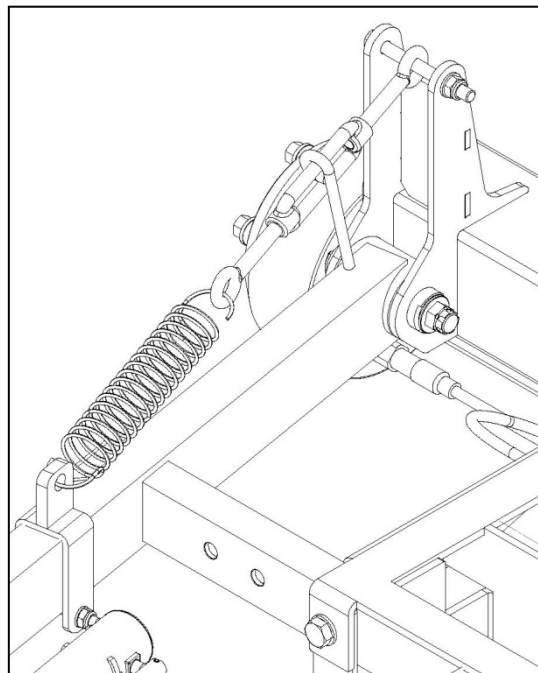

Assembling the transporter

Connecting the brake force transmitting system

After the drawbar has been attached, check as a first step whether the brake cable is connected to the intermediate lever behind the front axle.

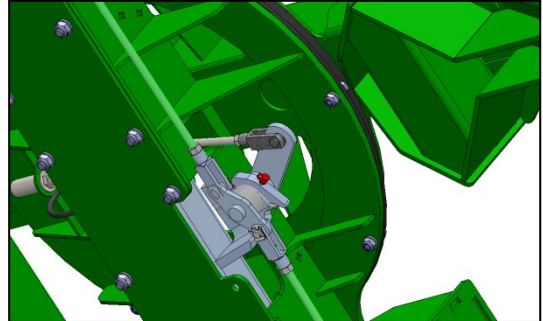

Then check whether the brake cable is routed through the hole in the drawbar frame.

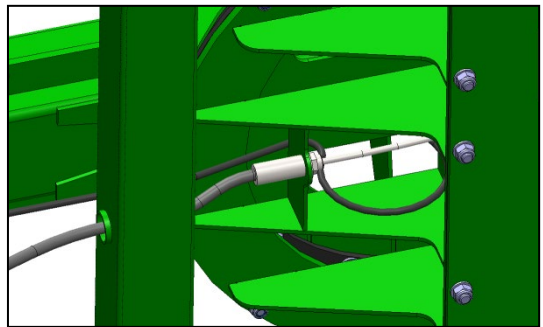

Next, thread the threaded cable end into the turnbuckle on the drawbar. Keep threading until the end is flush with the inner face of the turnbuckle. Lock it with the nut supplied.

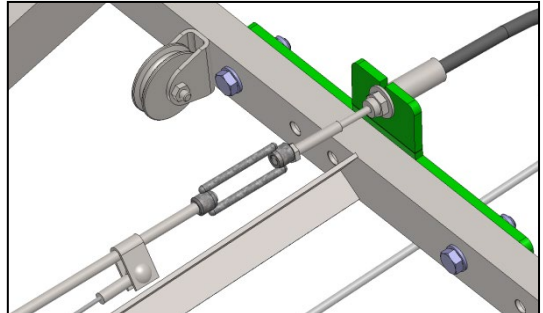

Setting up the brake

After the drawbar is mounted to the chassis, check the brake configuration. If necessary, re-adjust the brake.

► See section "Setting up the braking system" for instructions on setting up the service and parking brakes.

Assembling the transporter

Fitting and routing the breakaway cable

The breakaway cable is supplied separately as a coil that is fixed to the hand brake lever on the drawbar.

Attach its looped end to the ring on the hand brake lever. Do not use a snap hook.

Next, route the cable to the rear and thread it into the pulley. Then pull it again towards the hitch ring until it is taut.

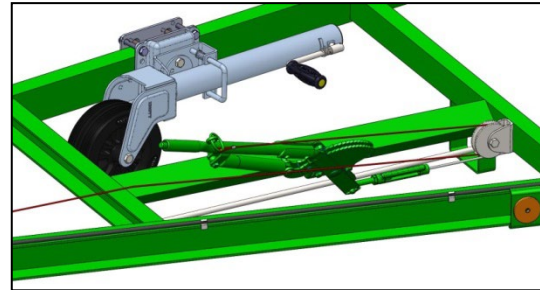

► See section “Operating the header transporter” for instructions on attaching the breakaway cable to the towing vehicle.

Fitting and routing the electric line to the towing vehicle

The electric line to the towing vehicle is tie strapped to the drawbar frame on delivery.

- After the drawbar is mounted to the chassis, remove the tie straps.
- Then route the line to the front so that a loop is formed between the grommet under the front axle and the drawbar frame. This loop is necessary for the front axle to make full lock to lock turns without straining, tearing or squeezing the electric line.

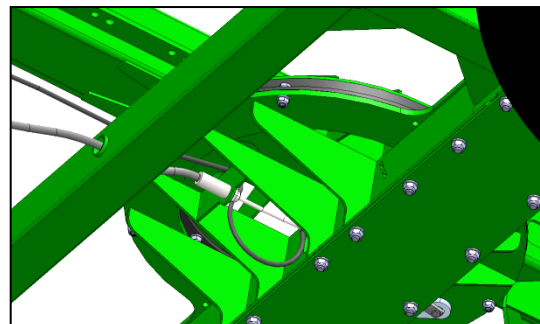
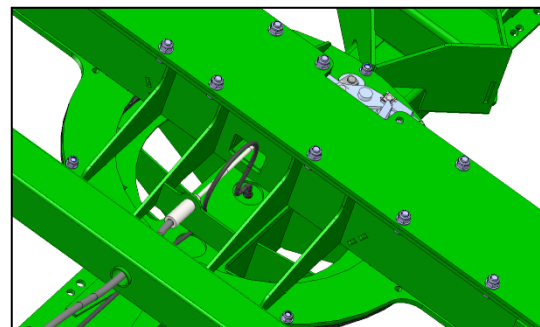

Assembling the transporter

- The next step is to route the line to the cable clips on the underside of the supporting sections of the drawbar.
- Route it through the clips to the front end. Ensure the front axle does neither tear nor squeeze this line when making a full lock-to-lock turn.
- Also ensure that the drawbar can travel up and down without straining, tearing or kinking the electric line.
- Next, loop the electric line around a supporting drawbar section and insert the connector in the holder provided on the drawbar.

► See section “Operating the header transporter” for instructions on connecting the electric line to the towing vehicle.

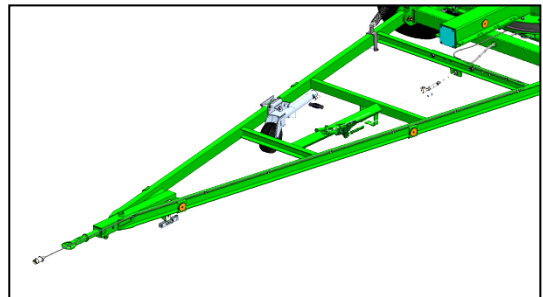
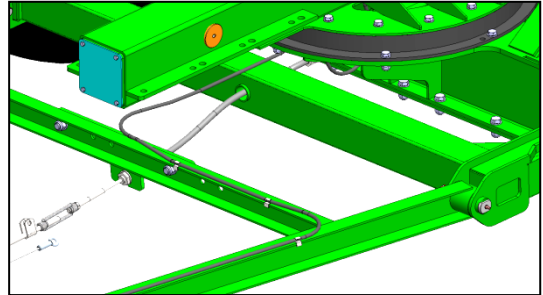

Operating the header transporter

Securing the load

All Zürn header transporters are equipped with form-fit load securing elements. These elements are specifically designed and tailored to each specific header model.

It is neither permitted to use any other type of load securing system nor to transport any load other than the header for which the header transporter is specified.

Never operate the header transporter without securing the header first.

After placing the header on the transporter, secure it immediately from falling off and sliding on the transporter.

The various load securing systems for the various types of headers are discussed in the following sections:

- 700PF
- RA / 600R / 600PF
- XA / 600X
- RDF / 600FD / 700FD

Special safety measures

The pointed and sharp parts on any header (knife sections, dividers, crop lifters, side knives) can cause personal injury. Some parts stick out from the header or the header transporter. Therefore it is necessary to take special safety measures before operating the header transporter on public roads.

Follow the instructions given in an expertise on Zürn header transporters by the German testing agency TÜV Süd. This expertise gives the following the instructions:

- Remove the dividers
- Remove the crop lifters
- Remove the side knives
- Fit the cutterbar guard

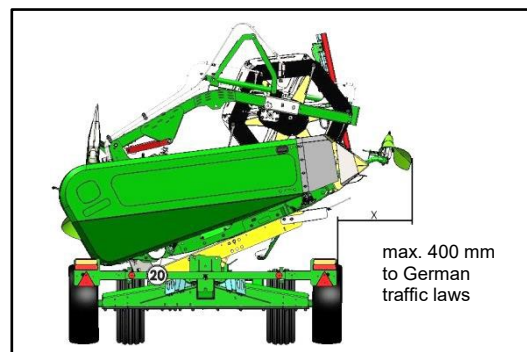

Operating the header transporter

Remove the dividers

For reasons of safety remove the dividers each time before you transport the header.

Folding the dividers into transport position is not necessarily enough to comply with traffic law requirements.



Remove the crop lifters

For reasons of safety, remove the crop lifters each time before you transport the header.



Remove the side knives

For reasons of safety, remove the side knives and fit their guards before each transport.



Operating the header transporter

Fit the cutterbar guard

The geometries of the cutterbar sections present a risk of injury. Therefore always guard the cutterbar with the appropriate elements.

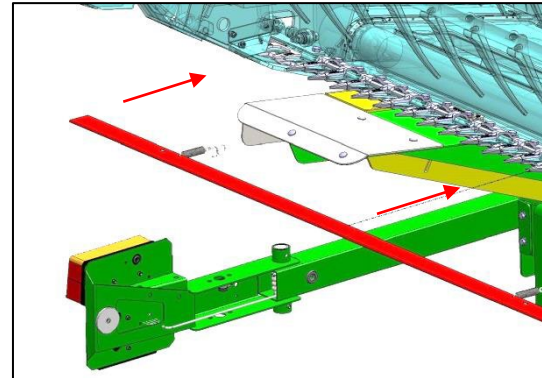

Retract the guide rod

All header transporters from Zürn Harvesting have a guide rod that helps operators loading the header on the transporter.

Move the guide rod into its working position before placing the header on the transporter. To do this, release the clamp that fixes the guide rod in its holder and pull out the rod until you can see the “Middle of the header” mark from the combine cab when the transporter is attached to the combine with the header on it.

In working position, the guide rod sticks out far from the chassis of the transporter. Therefore, push it in until it does not stick out from the header before the combination pulls off.

Also, fix the guide rod in its bracket ensuring it cannot slide in its tube during travel.

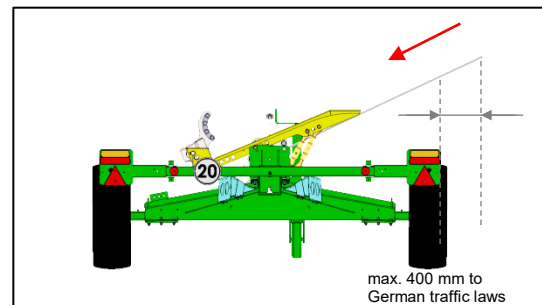
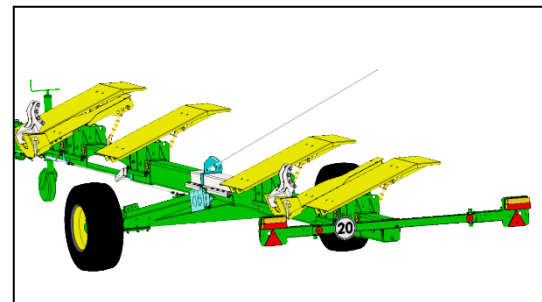

Operating the header transporter

Folding out the lights

All Zürn header transporters have foldable rear lights.

This solution allows you to swing the lights out of the way and protect them from potential damage when placing the header on the transporter.

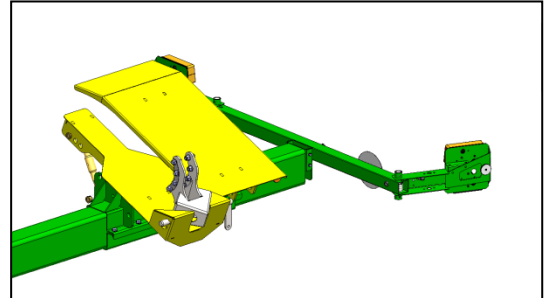

Extend both rear light holders before pulling off with the header transporter in tow. It is not permitted to operate the header transporter without the light holders being extended into transport position.

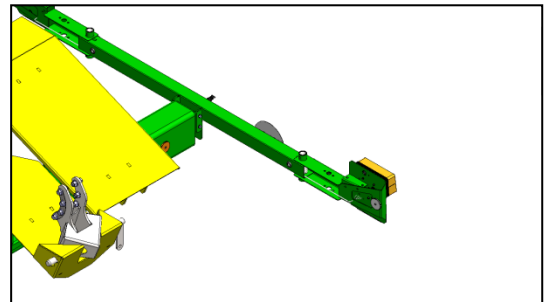

Operating the header transporter

The towing vehicle

The header transporters must be pulled by an agricultural tractor or a combine harvester. No other towing vehicles are permitted to pull the transporter.

The clevis size of the towing vehicle must match the size of the hitch ring on the header transporter (ID = 40mm).

The clevis must be appropriately sized to pull the gross transporter weight, i.e. the kerb weight of the transporter plus the kerb weight of the header.

Attachment to the towing vehicle and uncoupling from the towing vehicle

Stability

When attaching the header transporter to the towing vehicle and when uncoupling it from the towing vehicle, secure the transporter from moving and tipping over.

Always use both wheel chocks. Always apply the parking brake (if specified).

The wheels must be inflated to the correct pressure (► see section "Wheels"). It is not permitted to inflate the wheels to different pressures.

Take special safety measures when attaching a laden transporter to the towing vehicle.

Avoid steep downhill/uphill travel in line of travel of the transporter and avoid travelling on sloped roads.

Turn the front axle only through a small angle to ensure good stability.

Operating the header transporter

Adjusting the clevis on the towing vehicle

The clevis on the towing vehicle must be set to a height above road surface that matches one of the height settings that are available for the hitch ring.

If the clevis is too high or too low relative to the hitch ring, check whether the default angle between the hitch ring and the clevis is exceeded (for information on the hitch system refer to the documents of the towing vehicle).

If this is not the case, adjust the drawbar height as a next step.

The drawbar height is set on the height maintaining system.

► See the chapter “Assembling” for setting up the height maintaining system.

The jockey wheel offers an additional way of fine tuning the position of hitch ring to the clevis on the towing vehicle.

Attachment to the towing vehicle

When inching up to the header transporter, avoid pushing the transporter so this rolls off or overturns.

Ensure the hitch ring is properly inserted in the clevis and the clevis is closed properly.

Never push the header transporter toward the towing vehicle.

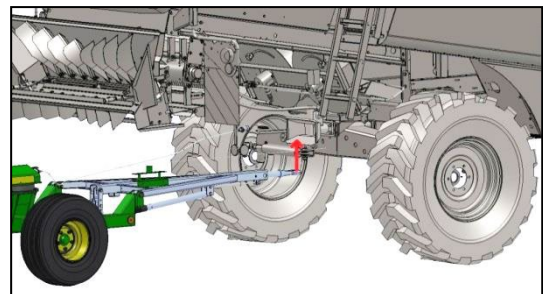

Operating the header transporter

On transporters with parking brake, attach the breakaway cable to the towing vehicle (e.g. to its rear axle).

Never fix the breakaway cable to the clevis.

Ensure you route the breakaway cable through the guide on the left side of the overrun head.

Ensure the breakaway cable is not taut when the combination is travelling around bends, because this would accidentally engage the parking brake on the header transporter.

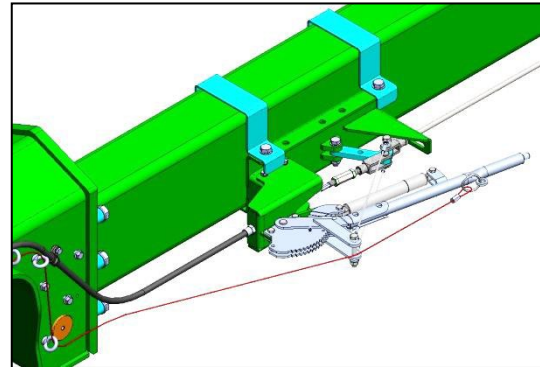

Operating the header transporter

Connecting the electric line to the towing vehicle

The towing vehicle must have a 7-pin socket (DIN 1724).

- After the transporter is coupled to the towing vehicle, connect the electric line to the 7-pin socket.
- Ensure that the electric line is long enough.
- After the electric line is connected to the towing vehicle, ensure it is not torn and damaged when the combination travels around bends.
- Also ensure that the electric line does not rub on machine parts or drag on the road.

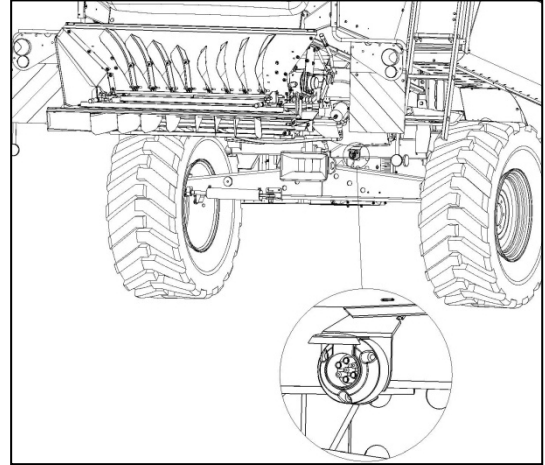

Operating the header transporter

Before operating the header transporter

Each time before you operate the header transporter, test it for proper road safety. In particular, test the brake system and all lights for correct operation, the tyres for correct inflation pressure and verify that all guards are in place and in good condition.

Each time before you operate the header transporter, bring all transporter and header parts that may pose a hazard to motorists into transport position.

Each time before you operate the header transporter, fold the jockey wheel into transport position and secure it.

Each time before you operate the header transporter, ensure the hitch ring is properly attached to the clevis, the breakaway cable is attached in a proper position on the towing vehicle (not to the clevis) and the electric line is connected.

Before the combination pulls away, ensure good operator visibility around the towing vehicle and the header transporter.

Driving, steering and braking the towing vehicle is very different when the header transporter is laden or unladen. Operators must be aware of this before they set out.

Avoid making sudden turns especially when driving across steep slopes and up- and downhill.

Always avoid situations in which the laden header transporter may be tilted significantly.

Use a helper when shunting in reverse and in obstructed visibility of the rear end of the transporter. Helpers must always stand in the visibility zone and must not step between the towing vehicle and the header transporter.

Check the brakes each time before you operate the combination!

Carry out a thorough inspection of the brake systems on a regular basis.

Repairs or set-up work on the brake system must be carried out solely by qualified dealerships.



Operating the header transporter

Forward speed

Never exceed the transporter's maximum speed. Exceeding the maximum speed reduces the load capacity and service life of the wheels.

Always adapt the forward speed to the prevailing conditions.

Placing the header on the transporter

Placing the header on the header transporter

Park the header transporter on firm, level ground. Apply the hand brake. Secure the transporter with wheel chocks or leave it coupled to the towing vehicle.

Bring all parts on the header into transport position before placing the header on the transporter. This means, remove the crop lifters and side knives (if fitted) and fit all guards that are required for road transport.

Verify that all securing pins on the transporter are removed from their locking position and in park position.

When placing the header on the transporter, observe all instructions regarding header attachment / removal as specified in the header / combine manual.



Then release the header from the combine's pendulum frame, disconnect the pto driveshaft and the multi-coupler / oil lines from the combine (see the combine manual).

Then, with the header still on the combine and the elevator raised as high as possible, inch the combine up to the transporter until the header is above the transporter. Align the middle of the reel with the guide rod. The header hovers now exactly above the header transporter.

Lower the elevator until the front edge of the header rests on the header supports.

As the hook catches approach the hooks lower header carefully onto the transporter. Ensure that both catches engage with the appropriate hooks. Next, remove the header from the combine as described in the combine manual.

Placing the header on the transporter

Lock the header in its transport position by inserting the locking pin. Secure the locking pin with the linch pin. Repeat on the other locking pin.

Before operating the header transporter, verify that the header is safely secured to avoid damage during transport.



Before travelling on public roads, attach the breakaway cable to the towing vehicle, retract the guide rod and secure it in its transport position. Connect and test the rear lights and move the light holders into transport position.



All locking pins must be secured, the cutterbar sections and crop lifters must be guarded and dividers (if fitted) folded up or removed before travelling on public roads.



To reattach the header to the combine, reverse the above procedure.



Placing the header on the transporter

Special header support kits

The Zürn header transporters can be specified with custom header supports for specific header models. A header transporter may transport only those header models it is specified for. Only use the manufacturer-specified mountings and brackets to secure a header.

See the following sections on “Securing the load” for detailed information on securing various header models to the transporter.



Placing the header on the transporter

The illustration shows the header after it has been placed on the transporter.

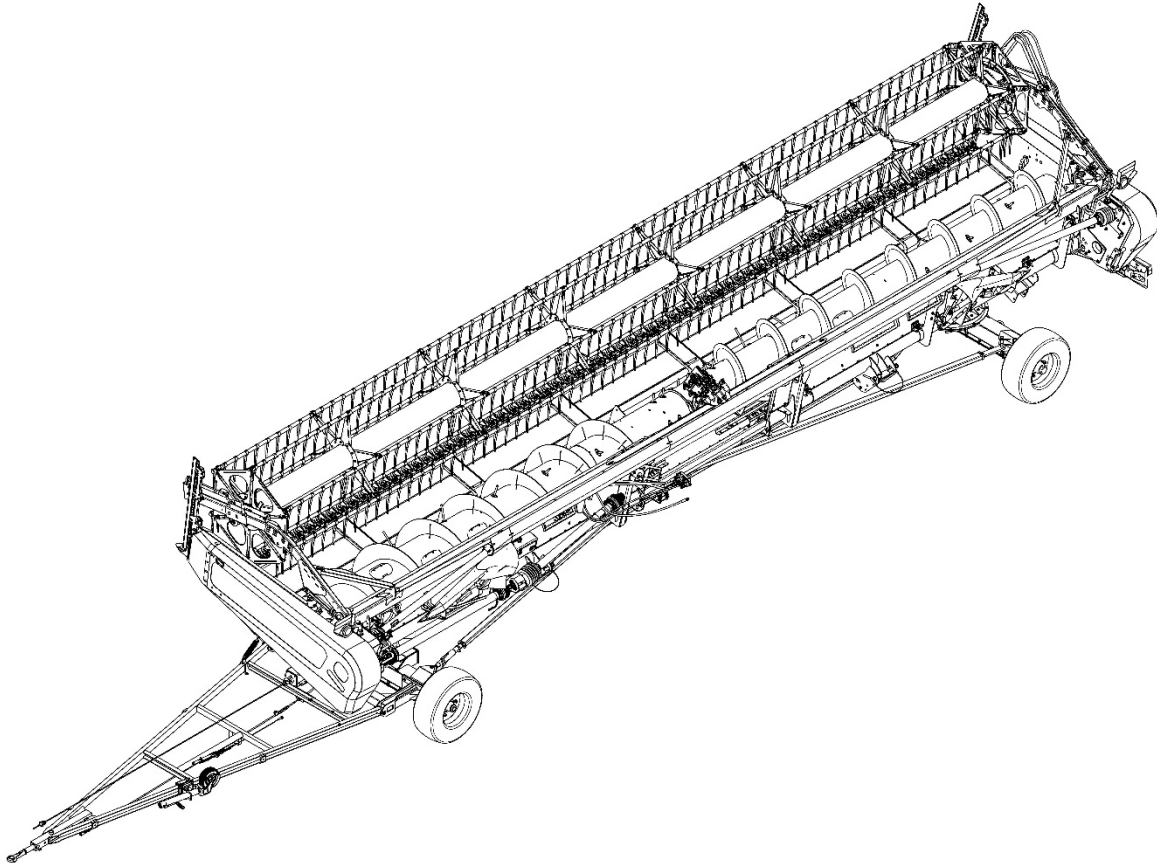

Securing the load

Securing ZÜRN 700PF headers

All instructions given below are merely recommendations. The actual settings are down to the specific combine make and model and its tyres. The proper adjustment of all load securing elements is essential for a smooth and safe handling of the header.

Adjusting the angle of the header supports

The angles of the header supports are adjusted individually and steplessly on the top link turnbuckles. Adjust each header support to the specific header before placing the header on the supports.

The recommended angle for 700PF headers is 25°.

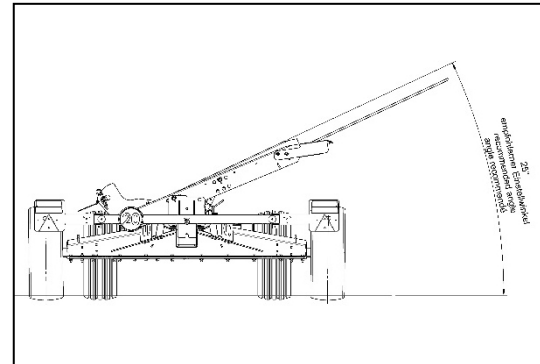

The illustration shows the best positions where the header supports should be bolted to their mountings and also the recommended length for the top links.

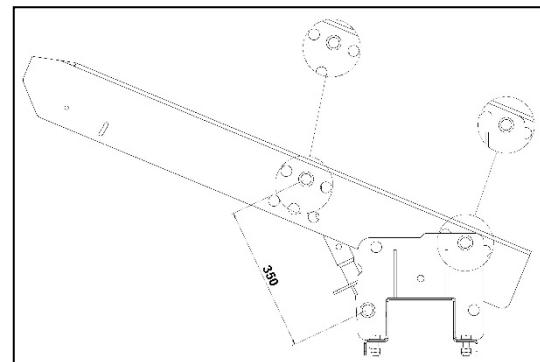
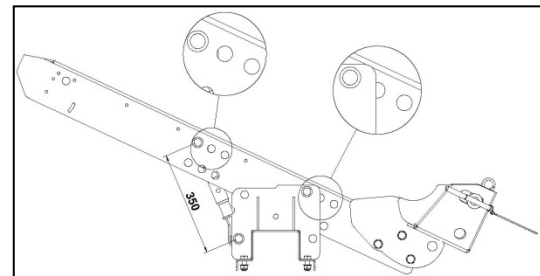

Securing the load

Ensure that both turnbuckles on the top link are set to equal lengths.

Adjust the turnbuckles, threading them at least 30 mm down. Do not undercut this depth, as this would put the header at risk of falling off the transporter.



Placing the header on the transporter

Remove the locking pins from the catches.

Then, with the header still attached to the combine and the elevator raised as high as possible, inch the combine up to the transporter until the header is above the transporter. Lower the elevator until the front edge of its floor contacts the header supports.

On the combine, remove the pins that secure the header to the machine. Reverse the combine while lowering the elevator and keep reversing until the header is being pulled against the stops.

Lower the elevator until it is possible to pull it out of the header by reversing the combine.

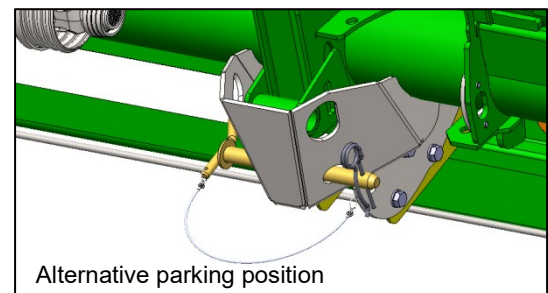
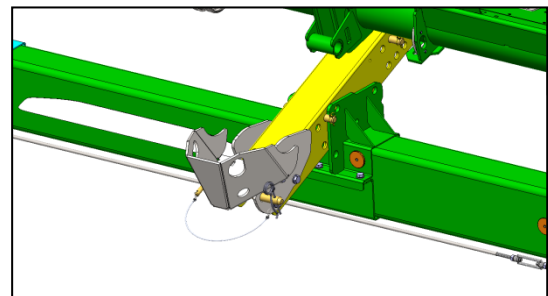

Securing the load

Securing the load

Fit and secure both locking pins with the R-clips provided.

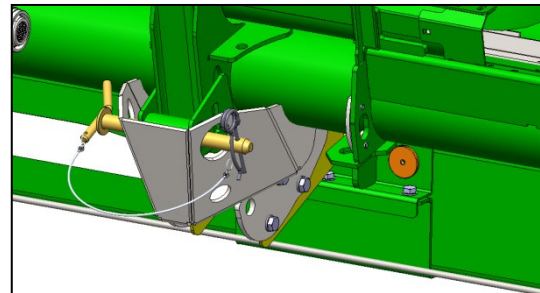
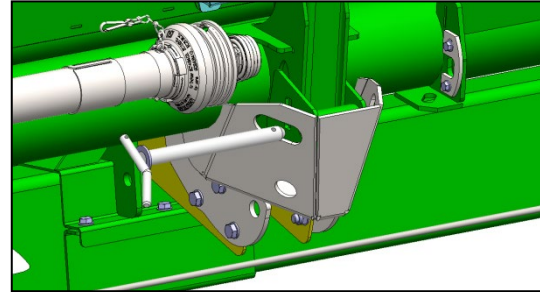

Removing the header from the transporter

Remove the R-clips from the locking pins, then remove both pins from the catches.

Inch the combine up to the transporter and header and raise / lower the elevator until it fits in the opening on the header.

Then raise the elevator, driving cautiously forward.

As the last step, attach the header to the combine by fitting the locking pins on the combine.

Securing the load

Securing John Deere RA / 600R / 600PF headers

All instructions given below are merely recommendations. The actual settings are down to the specific combine make and model and its tyres. The proper adjustment of all load securing elements is essential for smooth and safe handling of the header.

Adjusting the angle of the header supports

The angles of the header supports are adjusted individually and steplessly on the top link turnbuckles. Adjust each header support to the specific header before placing the header on the supportss.

The recommended angle for RA / 600R / 600PF headers is 25°.

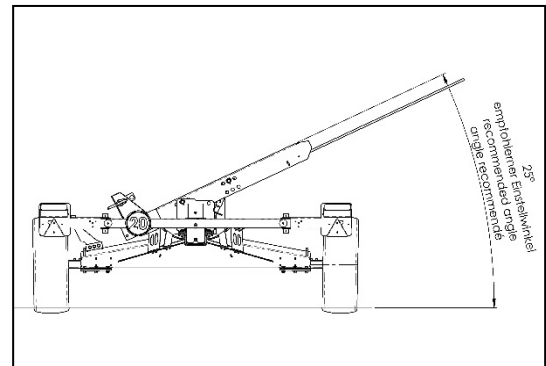

The illustration shows the best positions where the header supports should be bolted to their mountings and also the recommended length for the top links.

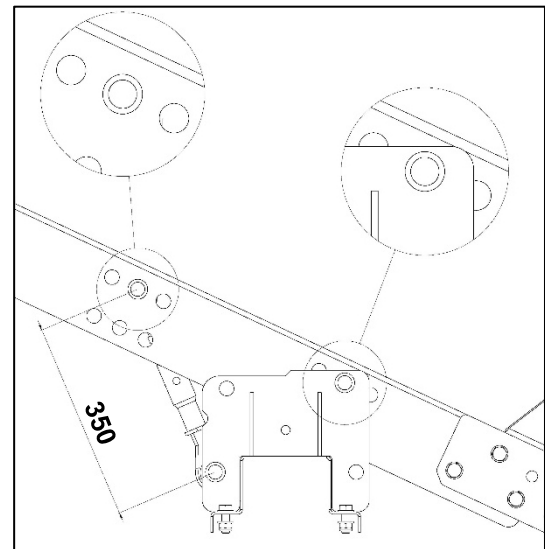

Ensure that both turnbuckles on the top link are set to equal lengths.

Adjust the turnbuckles, threading them at least 30 mm down. Do not undercut this depth, as this would put the header at risk of falling off the transporter.



Securing the load

Fitting the mechanical interfaces necessary to secure the header to the transporter

Bolt the two hook catches with four carriage bolts to the vertical header frame beam that is specified for the individual header size.

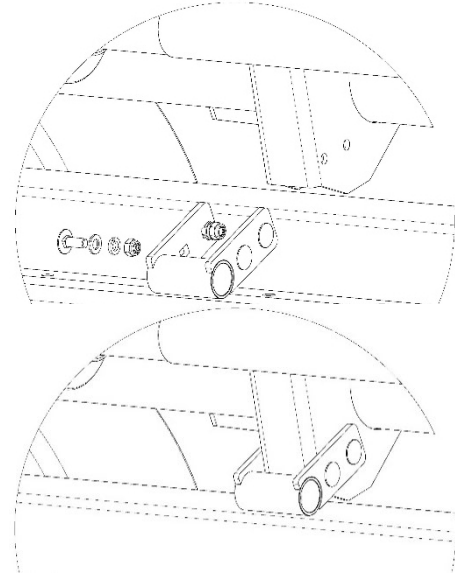

Placing the header on the transporter

The locking pins must be in their park positions.

Then, with the header still attached to the combine and the elevator raised as high as possible, inch the combine up to the transporter until the header is above the transporter. Lower the elevator until the front edge of its floor contacts the header supports.

On the combine, remove the pins that secure the header to the machine. Reverse the combine while lowering the elevator and keep reversing until the header is being pulled against the stops.

Lower the elevator until it is possible to pull it out of the header by reversing the combine.

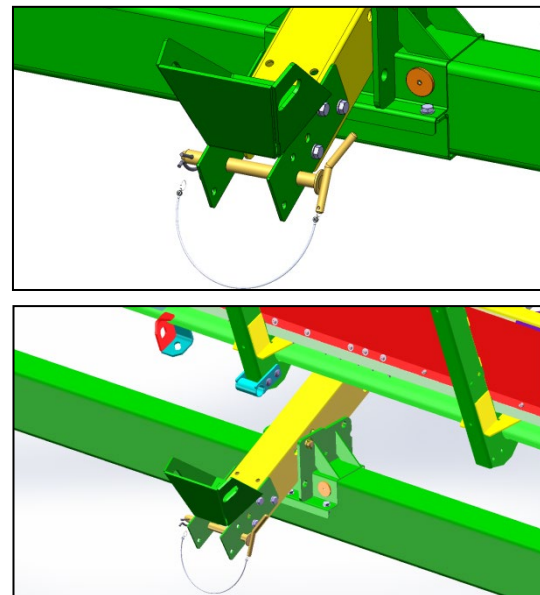

Securing the load

Securing the load

Fit and secure both locking pins with the R-clips provided.

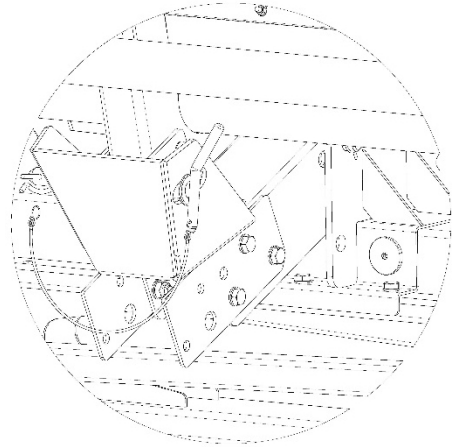

Removing the header from the transporter

Remove the R-clips from the locking pins, then remove both pins from the catches and fit them in their parking positions.

Inch the combine up to the transporter and header and raise / lower the elevator until it fits in the opening on the header.

Then raise the elevator, driving cautiously forward.

Next, secure the header to the combine by fitting the locking pins and lift the header off the transporter.

Securing the load

Securing John Deere XA / 600X headers

All instructions given below are merely recommendations. The actual settings are down to the specific combine make and model and its tyres. The proper adjustment of all load securing elements is essential for a smooth and safe handling of the header.

Adjusting the angle of the header supports

The angles of the header supports are adjusted individually and steplessly on the top link turnbuckles. Adjust each header support to the specific header before placing the header on the supports.

The recommended angle for XA / 600X headers is 22.5°.

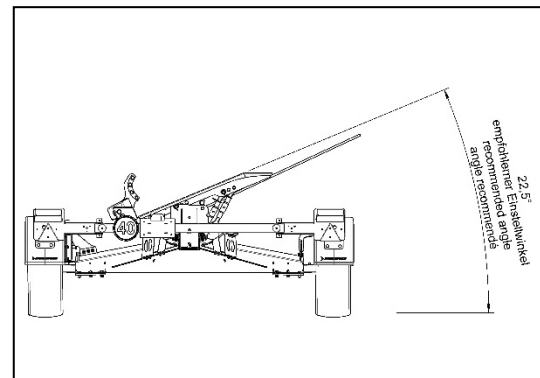

The illustration shows the best positions where the header supports should be bolted to their mountings and also the recommended length for the top links.

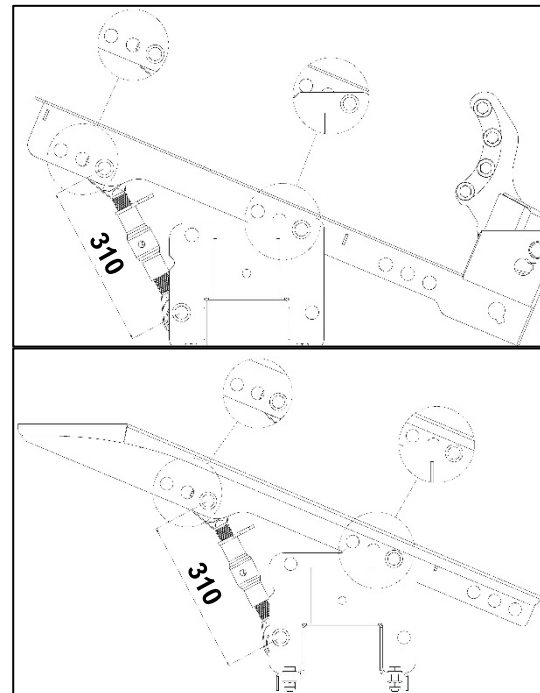

Securing the load

Ensure that both turnbuckles on the top link are set to equal lengths.

Adjust the turnbuckles, threading them at least 30 mm down. Do not undercut this depth, as this would put the header at risk of falling off the transporter.



Fitting the mechanical interfaces necessary to secure the header to the transporter

Bolt the two locking heads to the brackets on the header frame using eight bolts for each head.

The header transporter is supplied with (rust-free) chrome-nickel steel shims for filling small gaps and spaces.

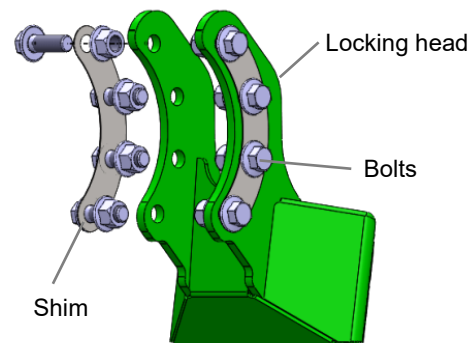

Use as many shims as necessary and fit them between the brackets and the sides of the locking heads. All elements will be set up correctly when there is only a minimum gap and no part is deformed permanently when being bolted in place.

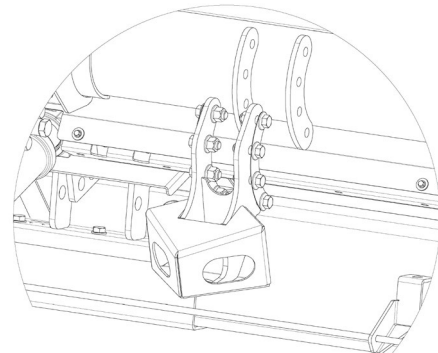

Securing the load

The load securing elements on an SWW-X6-625X transporter are not compatible with the mechanical interfaces on the header.



The following instructions apply to SWW-X6-625X models for transporting John Deere 625X headers.



This header has factory-fitted arched brackets on its back. The special geometries make it impossible to position and lock these brackets to their counterparts on the header transporter. Therefore it is necessary to relocate the header supports on the transporter, moving them inwards.

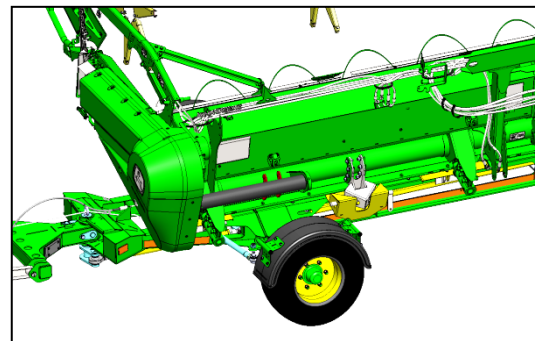

The header transporter is therefore supplied with four extra brackets that are welded to the header.

Two of these arched brackets must be welded to each end of the header. They serve as mountings for the locking heads.

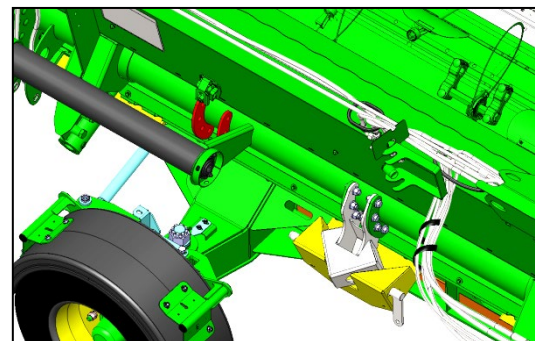

Securing the load

To position the brackets correctly on the header you will need two 16mm diameter steel tubes (preferably bank metal). These are not supplied with the transporter. Insert the two tubes into the two bottom holes on the factory-fitted brackets. Then push the two weld brackets onto the steel tubes. They should now be centred sufficiently well. The insides of their arches should lie flat on the curved header beam.

Next, slide the outer weld bracket on the round steel until it is spaced 547 mm from the inner factory-welded bracket. The gap between the two brackets to be welded is now 103mm.

Circle the weld area around the brackets with a pen. (Do not use a scribe!)

Sandpaper the area where you will apply the weld (around both brackets) down to the blank metal, removing the paint finish and primer.

As a next step, insert the round steels into the factory-fitted brackets and slide the two weld brackets onto the steel tubes, position them as illustrated and weld them to the header frame, applying an a3 fillet weld.

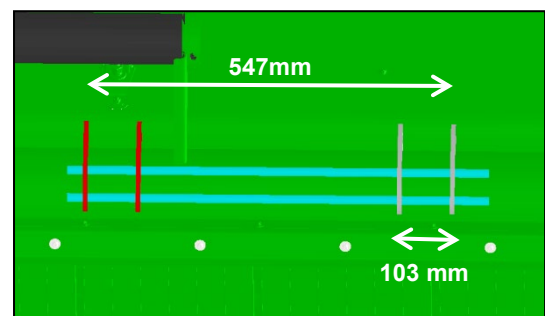
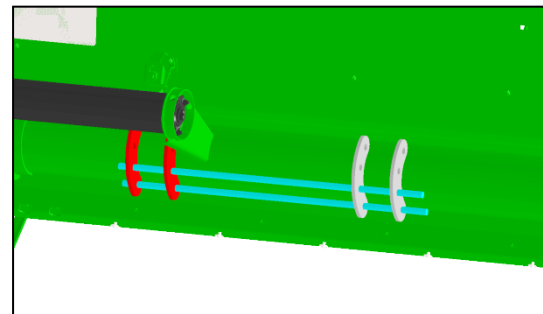

Caution! This weld must be carried out by a qualified welder.

The following welding techniques may be used:

111 (manual arc welding); minimum DIN EN ISO 2560-A E 35 0 RC 11 standard filler rod

135 (MAG welding); minimum ISO 14341-A-G 35 0 M21 3Si1 standard filler rod



Securing the load

After welding the brackets to the blank metal, prime the area and the welds. Wait until the primer has dried, then apply the paint coat.

Next attach the two locking heads to the welded brackets. Follow the instructions given above, using the fasteners supplied.

Securing the load

Placing the header on the transporter

Remove the locking pins from the prisms.

Then, with the header still attached to the combine and the elevator raised as high as possible, inch the combine up to the transporter until the header is above the transporter. Lower the elevator until the front edge of its floor contacts the header supports.

On the combine, remove the pins that secure the header to the machine. Reverse the combine while lowering the elevator and keep reversing until the header is being pulled against the stops on the prisms.

Lower the elevator until it is possible to pull it out of the header by reversing the combine.

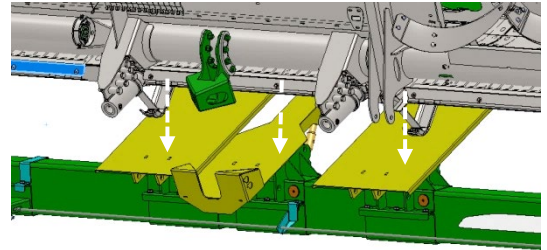

Securing the load

Fit and twist lock both locking pins to secure them from working loose.

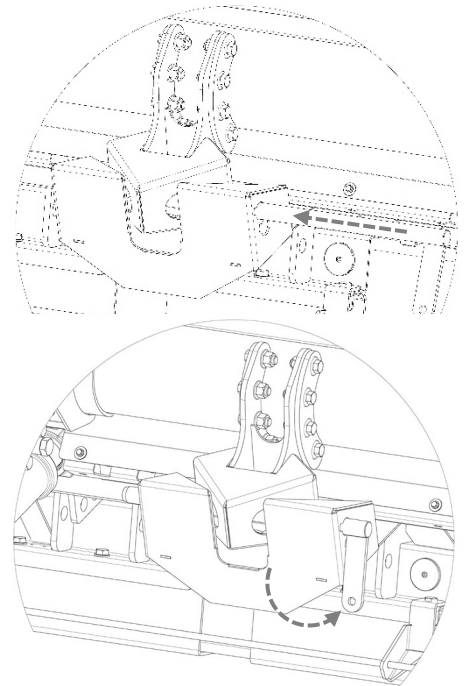

Securing the load

Removing the header from the transporter

Turn both locking pins until you can remove them from the prisms.

Pull out both pins until the hole in the prism is exposed and you can pull the locking heads from the prisms.

Store the locking pins on the bottom of the locking shims.

Inch the combine up to the transporter and header and raise / lower the elevator until it fits in the opening on the header.

Then raise the elevator, driving cautiously forward.

As the last step, attach the header to the combine by fitting the locking pins on the combine.

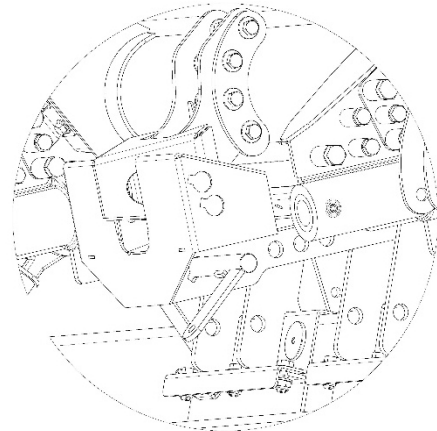
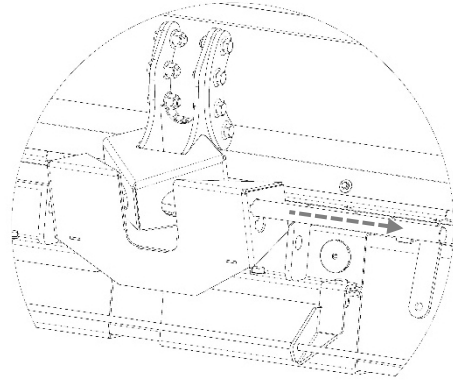

Securing the load

Securing John Deere RDF / 600FD / 700FD headers

All instructions given below are merely recommendations. The actual settings are down to the specific combine make and model and its tyres. The proper adjustment of all load securing elements is essential for a smooth and safe handling of the header.

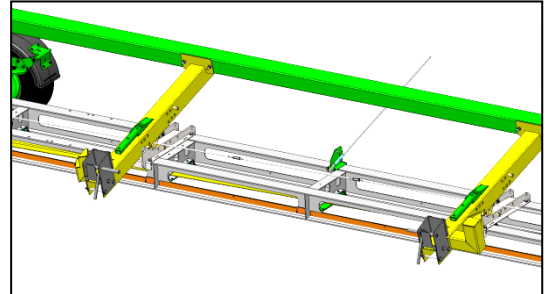

Adjusting the angle of the header supports

The angles of the header supports are adjusted individually and steplessly on the top link turnbuckles. Adjust each header support to the specific header before placing the header on the supports.

The recommended angle for RDF / 600FD / 700FD headers is 20°.

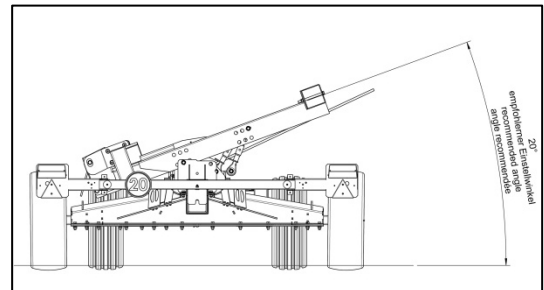

The illustrations show the best positions for installing the header supports to their mountings and also the recommended length for the top links.

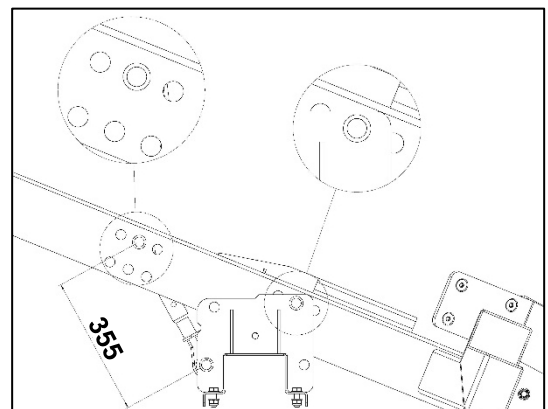
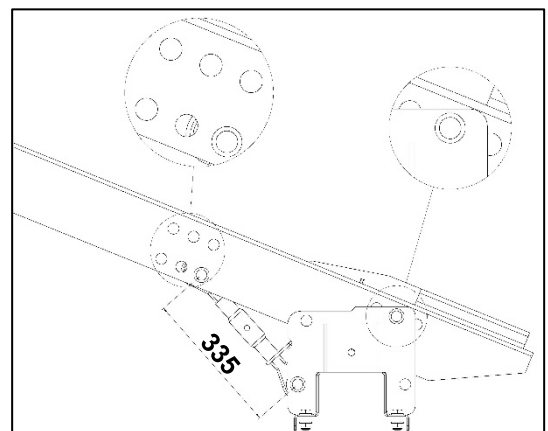

Securing the load

Ensure that both turnbuckles on the top link are set to equal lengths.

Adjust the turnbuckles, threading them at least 30 mm down. Do not undercut this depth, as this would put the header at risk of falling off the transporter.



Fitting the mechanical interfaces necessary to secure the header to the transporter

The header transporter is supplied with two extra plates that need to be welded to the header frame.

The bottom traverse on header frame has an overhang with four openings. Insert the four pins on the weld plate into these opening. This aligns the plate in its correct position. Circle the area around the plate with a pen. (Do not use a scriber!)

Sandpaper the area where you will apply the weld down to the blank metal, removing the paint finish and primer.

Weld the plate to the header frame, applying an a3 fillet weld all-round.

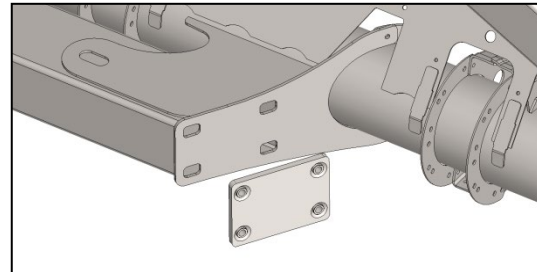

Caution! This weld must be carried out by a qualified welder.

The following welders may be used:

- 111 (manual arc welding); minimum DIN EN ISO 2560-A E 35 0 RC 11 standard filler rod
- 135 (MAG welding); filler rod to meet ISO 14341-A-G 35 0 M21 3Si1 standard as a minimum



Securing the load

After welding the plates to the header, prime the metal areas and welds. Wait until the primer has dried, then apply the paint coat.

Attach each of the two brackets with four countersunk screws to the M16 threads on the header frame.

Attach the weld plates and brackets to both ends of the header frame as described above. The header is now ready for placement on the transporter.

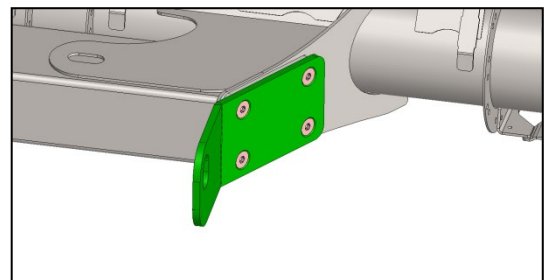
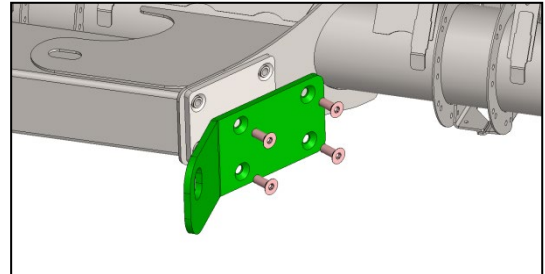

Placing the header on the transporter

Remove the locking pins from the stop catches.

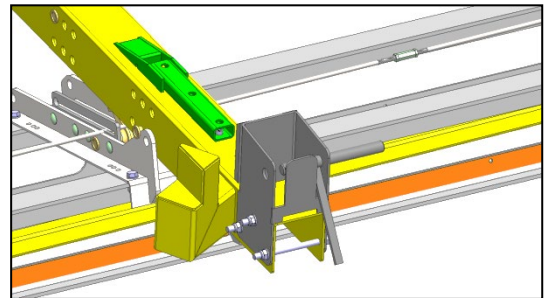

Then, with the header still attached to the combine and the elevator raised as high as possible, inch the combine up to the transporter until the header is above the transporter. Lower the elevator until the front edge of its floor contacts the axial beam that supports the cutterbar.

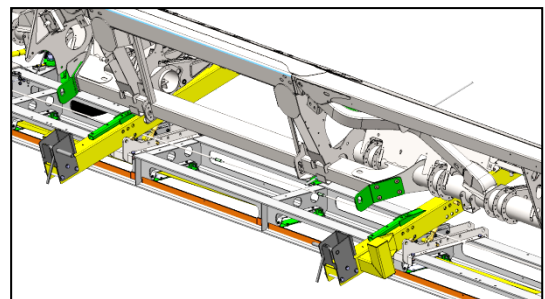

On the combine, remove the pins that secure the header to the machine. Reverse the combine while lowering the elevator and keep reversing until the header is being pulled against the faces on the stop catches.

Lower the elevator until it is possible to pull it out of the header by reversing the combine.

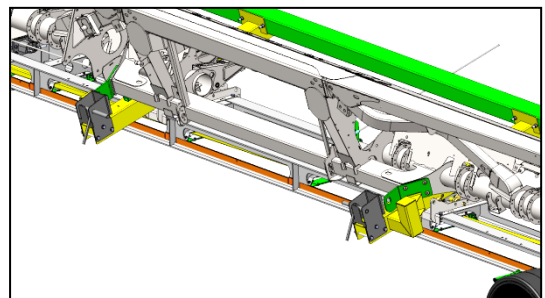

Securing the load

Securing the load

Insert both locking pins into the brackets that were bolted to the header and twist lock to secure them from working loose.

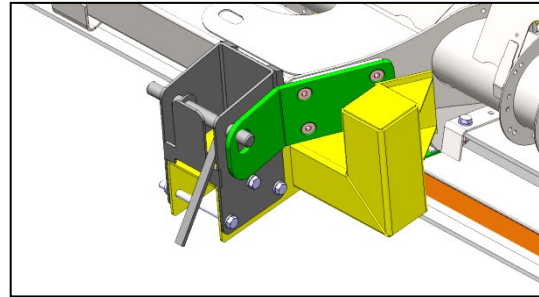

Removing the header from the transporter

Turn both locking pins until you can remove them from their brackets.

Pull both locking pins from the stop catches until the brackets are released and both locking pins lock into place.

Inch the combine up to the transporter and header and raise / lower the elevator until it fits in the opening on the header.

Then raise the elevator, driving cautiously forward.

As the last step, attach the header to the combine by fitting the locking pins on the combine.

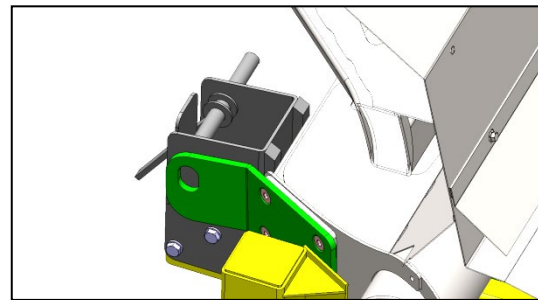

Setting up the steering system

Setting up the double-axle steering system

The double-axle steering system is set mechanically on the two tie rods (push-pullrods) (in straight ahead position).

Move the front axle into straight ahead position:

- Remove the pin(s) from the push-pullrod(s) on the front axle.
- Place a ruler, water level or a similar tool on the outside of the left tyre. Determine how much the ruler sticks out to the rear: Ensure this measure is the same on the right tyre.
- Measure the distance from the inside edge of the ruler on the left wheel to the chassis.
- Place the ruler on the outside of the right tyre.
- Measure the distance from the inside edge of the ruler on the right wheel to the chassis. Ensure this measure is identical on both sides.
- Steer the drawbar and thereby the front axle until the distance between the ruler and the chassis is identical on both sides.
- Mark the current position of the front axle on the turntable with a pen.

In the same way, steer the rear axle into the straight ahead position. Mark the current position of the rear axle on the turntable with a pen.

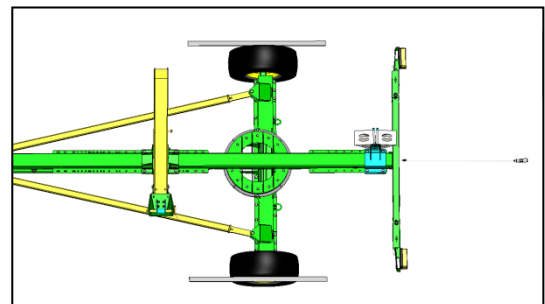
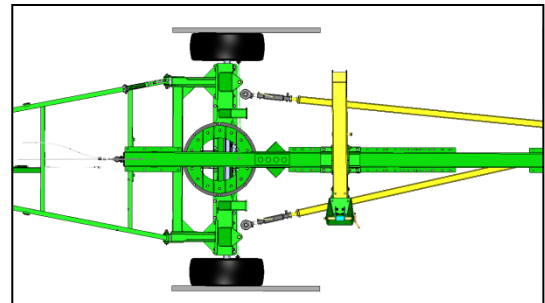
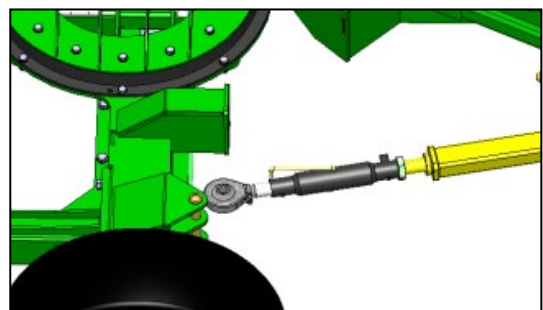
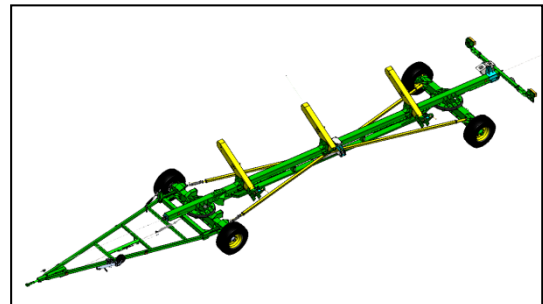

Setting up the steering system

- Alter the length of the push-pullrod by adjusting the top link tube until the pin can easily be inserted into the front axle.
- As you do this, ensure that neither axle is moving. Ensure they are in straight ahead position and in line with the mark on the turntable. If necessary, stop both axles from turning by fixing them with appropriate means.
- After the push-pullrods are adjusted correctly, tighten the locking nuts.

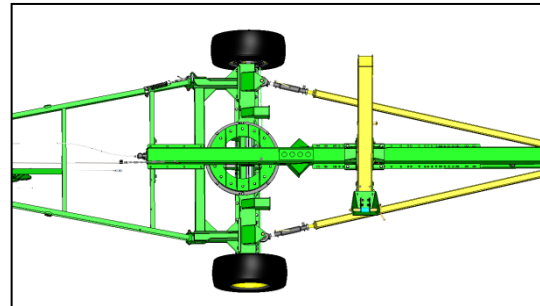
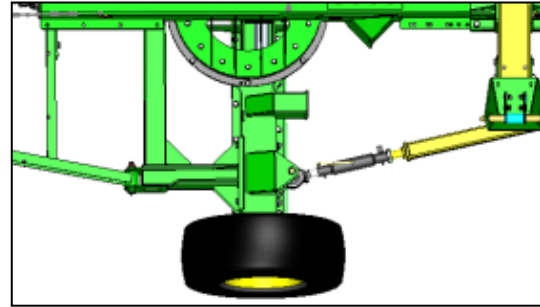

On transporters with two push-pullrods:

Twist both push-pullrods against each other by turning the top link tubes and extending the push-pullrods to minimise the leeway of the pins.

Information for transporters with one push-pullrod:

The steering system on transporters with one tie rod (25ft headers) is set up in analogy. Yet here the length is adjusted on one push-pullrod only.

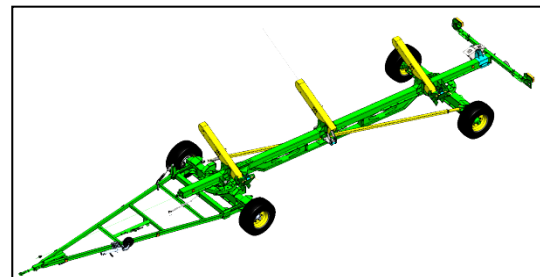

Setting up the braking system

Understanding the overrun brake and the auto reverse system

For a better understanding of how the brake systems are set up and serviced, the following paragraphs explain all major components that form the brake system.

General

All braked header transporters from Zürn Harvesting have a mechanical brake system (overrun brake). This consists of the overrun device on the drawbar, the system of cables or rods that transmit the brake force to the wheels and the brakes themselves.

Road traffic laws require all braked vehicles to have two independent braking systems – the service brake and the parking brake. The service brake is actuated by the overrun device. The parking brake is actuated by the hand brake lever which sits either on the drawbar or on one side of the header transporter.

Components of the overrun braking system (service brake)

The following components are found on all header transporters from Zürn Harvesting that have a service brake:

- Overrun head with hitch ring
- Bell crank
- Brake force transmitting system
- Transfer lever
- Wheel brakes

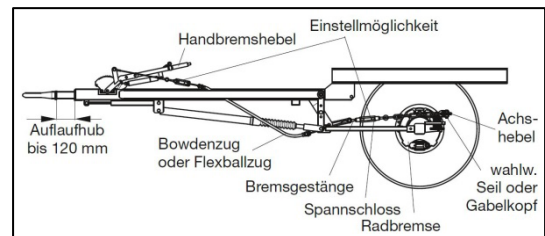

An overrun/service brake [Source: BPW]

Setting up the braking system

How the overrun brake system works

An overrun brake transforms kinetic energy into braking energy and applies the braking force as uniformly as possible to all wheels.

This is done by an angled mechanism that transforms the load of the overrunning trailer into pull on the brake rods.

When the service brake is applied, the pushrod that is attached to the hitch ring assembly or the hitch ring itself pushes the bell crank which is linked to rods and cables that act on the drum brakes of the header transporter. When the towing vehicle brakes, the trailer is pushing forward which triggers the brake.

The device has an integral oil damper that cuts out the jolting. This dampens the shock loading as the trailer is pushing forward and actuates the trailer brake more gently.

Adjusting the brake pads automatically

It is necessary to routinely inspect and adjust the brake pads and brake rods.

Worn brake pads or an excessive gap between the pads and brake drum will delay the brake response and result in a longer stopping distance. Therefore the brake pads on the wheels are adjusted automatically to ensure an optimum gap at all times.

The brake adjusts the gap between the drum and the pads automatically whenever it is too wide.

Setting up the braking system

The components of the service and parking brake systems (SWW-X2)

The SWW-X2 header transporter models feature the following components:

- Drawbar with integral overrun device
- The brake force transmitting system on the drawbar
- Hand brake lever with brake force transmitting elements
- Breakaway cable
- Transfer levers on the front and rear axle
- Wheel brakes on the front and rear axles

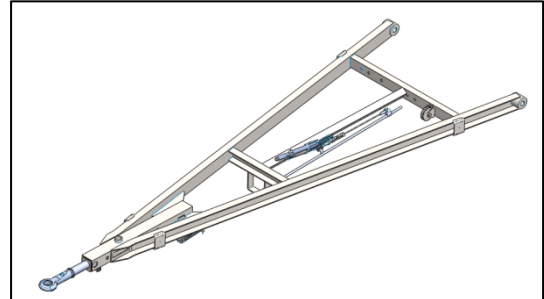

Drawbar with overrun device – SWW-X2

The drawbar with overrun device transfers the pulling and steering movements of the towing vehicle to the header transporter. The following components make up the drawbar on the SWW-X2 models:

- The drawbar proper,
- the hitch ring,
- the bell crank,
- the transmitting mechanism,
- the hydraulic damper,
- the height control and
- the connecting elements to the braking system.

The hand brake lever is mounted on the drawbar on the SWW-X2 models.

The following paragraphs describe the main components in their default (released) positions. These positions are a requirement for a safe and effective configuration of the brake system.

Setting up the braking system

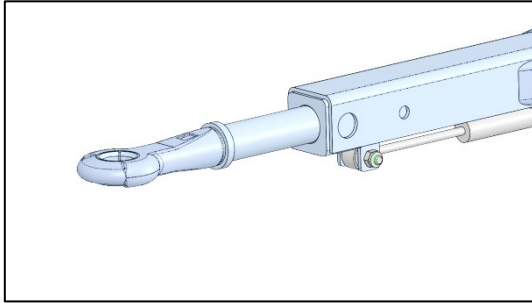

Overrun device – hitch ring in release position = default position, i.e. fully extended to 120mm

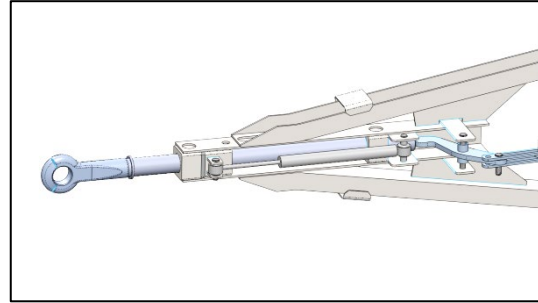

Hydraulic damper in release position = default position, i.e. fully extended to 120mm

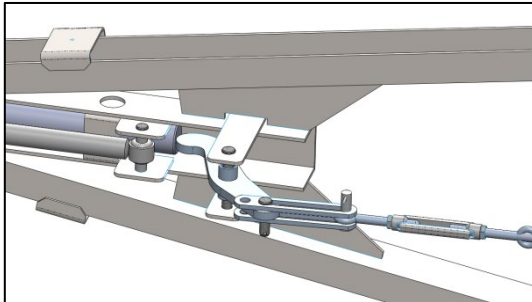

The overrun device: The bell crank linkage contacts the forward-facing rear plate of the hitch ring assembly = default position

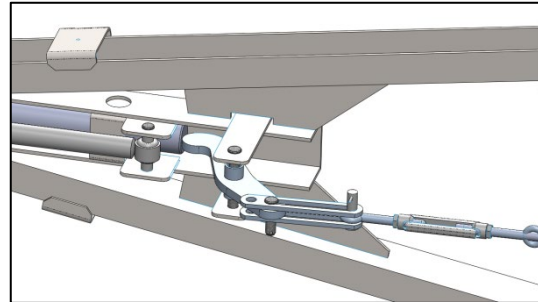

The overrun device: The bell crank linkage is connected to the linkage mechanism with the help of the pin.

Caution! Do not fit the pin in the front hole in the linkage mechanism but in the elongated hole!

In default position the bell crank linkage is tilted all the way forward and contacts the rear plate of the hitch ring assembly. The linkage mechanism and the eye bolt with turnbuckle

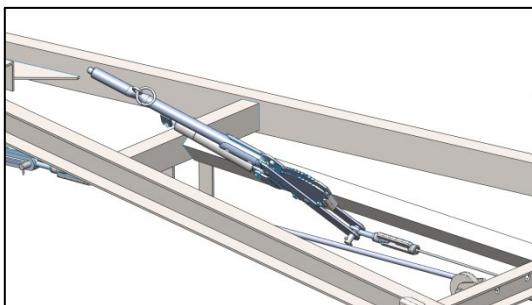

The hand brake lever in release position (default position) = it is fully released

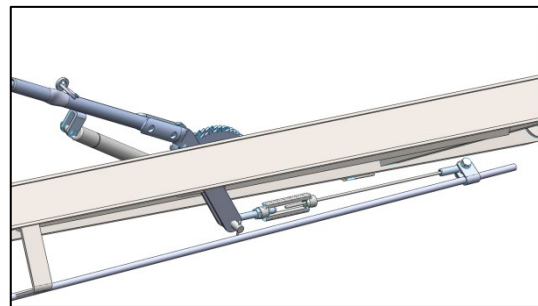

The hand brake lever with brake force transmitting system: In default position (the lever fully released), it should be possible to adjust the turnbuckle → Therefore thread in the pin all the way into the turnbuckle.

Setting up the braking system

Setting up the service brake (SWW-X2)

Bringing the overrun device and transmitting elements into default position

- Ensure that the hitch ring is extended all the way. Its full stroke is 120mm on the SWW-X2.
 - The top part of the bell crank linkage is inclined all the way forward.
 - Ensure that the pin at the bottom of the bell crank is inserted in the elongated hole of the linkage mechanism.
 - Ensure to pull the mechanism and the eye bolt with turnbuckle all the way to the rear.
 - When the hitch rings moves or when the hand brake lever is operated, the cable from the drawbar to the transfer lever behind the front axle must operate instantly and without any no-load stroke the transfer lever. This in turn operates the two pullrods on the left and right brakes on the front axle.
 - If this is not the case, alter the configuration between the drawbar and the transfer lever and eliminate any loose connections or no-load strokes.
 - The overrun device and the brake force transmitting system are now in default position and set up without play.
-

Setting up the braking system

Configuring the wheel brakes on the front axle – all SWW-X2 variants

- Ensure that the hand brake lever on the drawbar is in default position (= released)
- Jack up and raise the front axle and prop it with suitable blocks or similar items on both sides so the two wheels can rotate freely.
- Ensure to secure the transporter from slipping, falling or flipping.

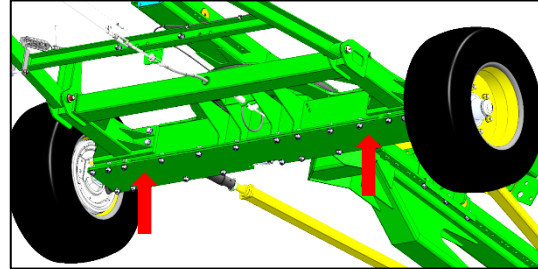

Jack up and raise the front axle and prop it with suitable elements.

- Also ensure that the brake cable to the front wheels is not connected to the transfer lever right behind the front axle while the following setting procedures are carried out. Also ensure that the brake linkages are under no strain during the procedure.

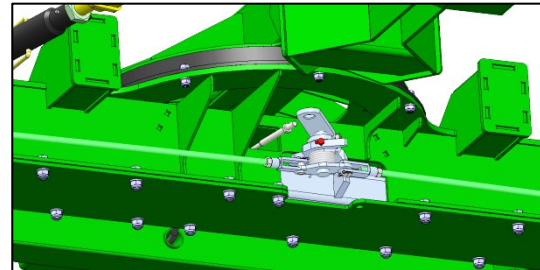

Disconnect the cables from the transfer lever when setting up the wheel brakes.

Setting up the braking system

Setting up the service brake on the front axle (SWW-X2 with 6t braked axle)

- for all SWW-X2 export versions (all header widths)
- for all SWW-X2 models for German homologation (up to 25ft headers)

- Next turn the nearside wheel in direction of travel.

The setting is correct, if you can hear a faintly grinding noise as the brake shoes drag on the drum. You should feel a slight resistance as you turn the wheels.

If you don't feel any resistance when turning the nearside wheel in forward direction, optimise the brake configuration on this wheel.

- To do this, lock the cam of the wheel brake using a less than 4mm diameter pin (tool A) and insert this in the pin hole (at least 50mm deep)
 - ▶ see section "Auto reverse system"
- Next, thread the adjuster bolt B into the carrier plate on the nearside brake, turning it clockwise until the wheel is fixed.
- Then thread it back out until you can no longer feel the wheel braking when you turn it in forward direction.

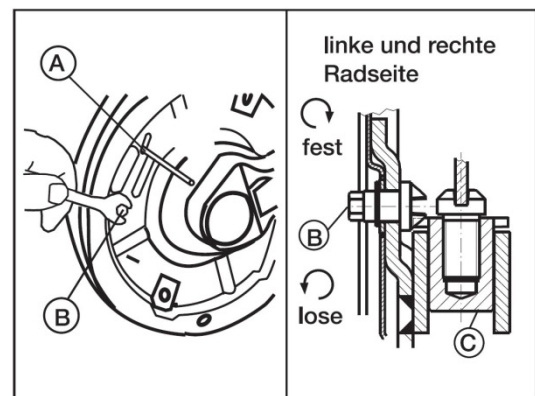
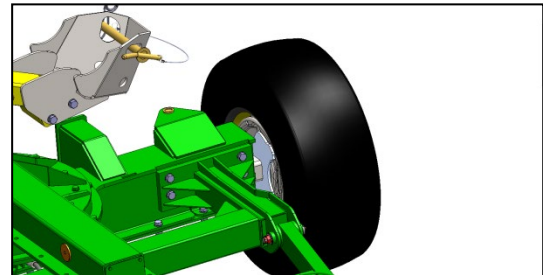

Source: BPW

Next, repeat the above procedure on the offside wheel.

- Caution! Only use the adjuster bolts to readjust the wheel brake!
- Tool = remove the locking pin A from the cam

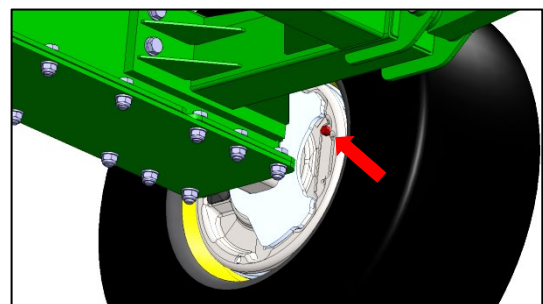

Turn the adjuster bolt clockwise to tighten it.

Setting up the braking system

- Next, reconnect the wheel brakes to the brake force transmitting system by refitting the brake cable to the bell crank linkage in front of the rear axle.
- Ensure that the hitch ring is in its default position, which means it is fully extended.
- Apply the hand brake lever only slightly and test whether an identical brake torque is applied to both wheels.
- Test whether all brakes are applied simultaneously.

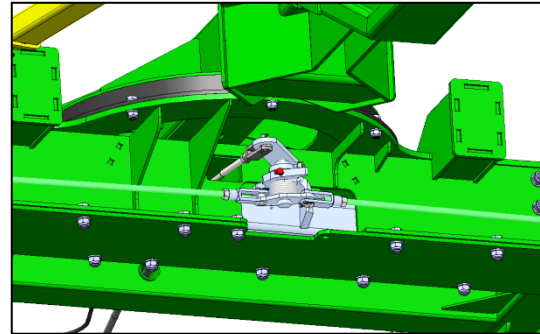

In general, the cables should be set rather tight before the machine is operated the first time. This is recommended, because the brake pads still need adapting to the brake shoes during the initial phase of operation. After that the shoes will apply a uniform pressure.

This completes the configuration of the service brake.

Lower the front wheels back to the ground and apply the parking brake to secure the header transporter from rolling. The next step is to set up the elements that carry the header.

Setting up the braking system

Setting up the service brake on the front axle (SWW-X2 with 8t braked axle)

– for all SWW-X2 models for German homologation (30ft and wider headers)

- Next turn the nearside wheel in direction of travel.

The setting is correct, if you can hear a faintly grinding noise as the brake shoes drag on the drum. You should feel a slight resistance as you turn the wheels.

If you don't feel any resistance when turning the nearside wheel in forward direction, optimise the brake configuration on this wheel.

- To do this, tighten the adjuster bolt on the wheel brake with a screw driver in direction of the arrow. Continue tightening until the wheel gives proper resistance in direction of travel. Note: The screwdriver should be kinked to get into the confined space between the axle cross member and the brake hub.

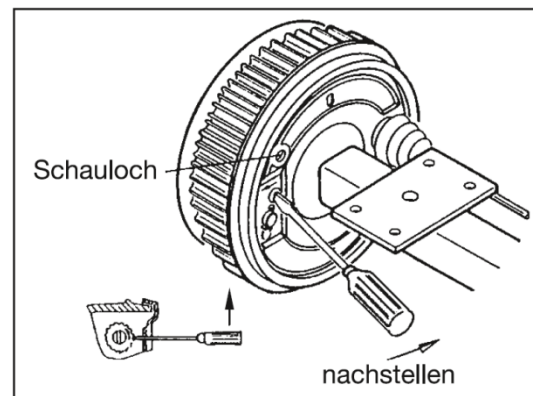
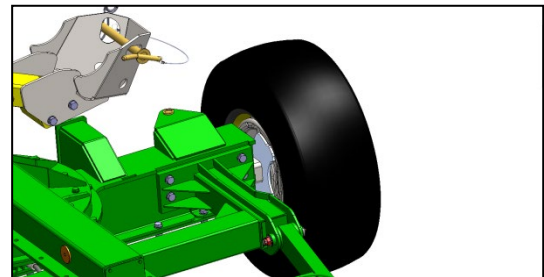

Source: BPW

- Turn the adjuster bolt back until you can no longer feel the wheel braking when you turn it in forward direction.

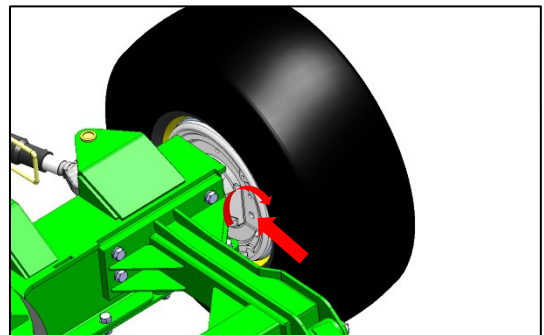

Insert the kinked screwdriver here and tighten the adjuster bolt inside the brake.

Setting up the braking system

Next, repeat the above procedure on the offside wheel.

- Caution! Readjust the wheel brake only on the adjuster bolt!
- Next, reconnect the wheel brakes to the brake force transmitting system by refitting the brake cable to the bell crank linkage in front of the rear axle.
- Ensure that the hitch ring is in its default position, which means it is fully extended.
- Apply the hand brake lever only slightly and test whether an identical brake torque is applied to both wheels.
- Test whether all brakes are applied simultaneously.

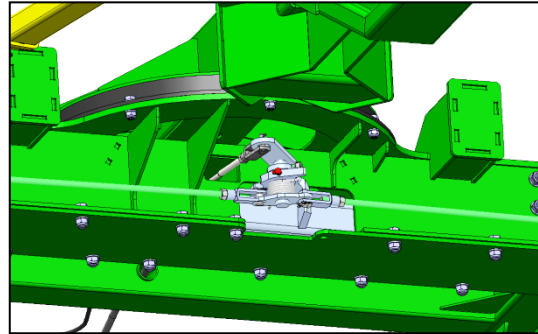

In general, the cables should be set rather tight before the machine is operated the first time. This is recommended, because the brake pads still need adapting to the brake shoes during the initial phase of operation. After that the shoes will apply a uniform pressure.

This completes the configuration of the service brake.

Lower the front wheels back to the ground and apply the parking brake to secure the header transporter from rolling. The next step is to set up the elements that carry the header.

Setting up the braking system

Checking the configuration of the service brake on the laden machine

The correct configuration of the service brake is verified on the laden machine. This completes the start-up operations. To do this, place the header on the transporter.

- After placing the header on the transporter and attaching the transporter to the towing vehicle, drive the combination at a moderate speed of 10-15km/h. Then brake the towing vehicle.
- Doing this, watch the header transporter and how it responds.
- You must feel that the transporter is slowing down.
- To 'train' the brake pads and increase the grip it is necessary to brake the towing vehicle about 20 times while driving at approx. 10-15km/h.
- After this 'training period' apply the brake again, this time while driving at approx. 15km/h.
- Watch the hitch ring and how it responds.
- If the hitch ring retracts all the way (120mm) to stop, the brake will need adjusting.
- To adjust the brake, adjust the turnbuckle in front of the front axle. As you do this, watch the brake lever behind the axle and whether it slightly moves forward.
- After the turnbuckle is adjusted, drive and brake the combination again at 15km/h, watching the hitch ring and how it responds.
- Should the hitch ring continue to retract all the way and even hit stop, adjust the brake again on the turnbuckle.
- Repeat the procedure until the hitch ring no longer retracts all the way or even hits stop when the transporter is operated and braked at its maximum forward speed.
- When this is the case, the service brake is correctly configured.
- As a last step, verify that the wheel brakes and the entire brake force transmitting system are correctly configured.
- This completes the start-up operations of the brake.
- After the above adjustments are completed, test the brake force transmitting system between the overrun head/drawbar and the axle for loose connections or damage.

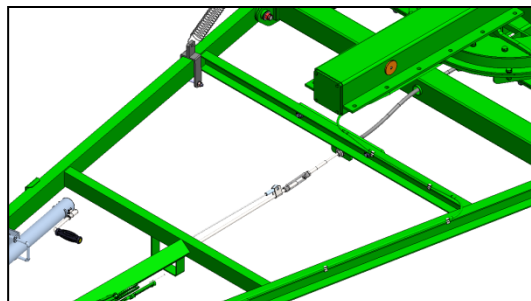

Setting up the braking system

Setting up the parking brake (SWW-X2)

After the service brake is configured correctly, it is necessary to set up the parking brake. This procedure is carried out on the unladen vehicle.

Checking the braking position of the hand brake lever

- Operate the lever.
- After the lever has covered about 1/3 of its path on the ratchet bracket it should be in its braking position and not move any further.
- Should this not be the case and the lever continues to move much further forward, undo the locking nut on the turnbuckle behind the hand brake lever.
- Next, increase the tension by reducing the length of the cable from the hand brake lever to the pullrod under the drawbar lever. This is done by adjusting the turnbuckle.
- As a last step, verify if applying the brakes restricts the path of the hand brake lever to about one third of the available circumference.
- The braking position is okay when the lever covers only about 1/3 on the ratchet bracket when the brake lever is applied.
- Retighten the locking nut.

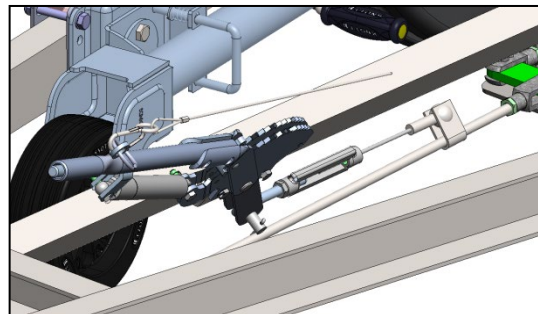
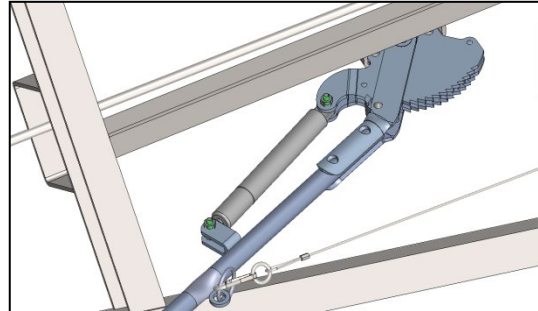

Setting up the braking system

Checking the configuration of the parking brake on the laden machine

As a last step, check the correct configuration of the parking brake on the laden machine. This completes the start-up operations. To do this, place the header on the transporter.

- Place the header on the transporter and attach the transporter to the towing vehicle.
 - Apply the parking brake.
 - Then start the tractor or combine and try to pull off with the header transporter in tow.
 - If the transporter wheels do not move, the parking brake is set correctly.
 - However, should the wheels on the transporter turn as the towing vehicle is pulling off, the parking brake will need optimising.
 - To do this, undo the locking nut on the turnbuckle behind the hand brake lever. Then adjust the turnbuckle to reduce the cable length and increase the tension.
 - Then apply the parking brake and start the towing vehicle, trying to pull off with the transporter in tow. Watch the wheels.
 - If they are not turning, the configuration of the parking brake is completed.
-

Automatic Reversing Mechanism

Function of the reversing mechanism

A special brake shoe support arrangement in the wheel brake cancelsthe braking effect while reversing and thereby ensures the vehicle can be backed up effortlessly at any time, even uphill. This therefore rendersunnecessary a reverse locking lever for mechanical locking operation. Normal brake operation is resumed immediately when driving forwards.

The associated overrun device is equipped with a gas pressure-assisted hydraulic shock absorber maximizing control in both driving and braking conditions. The individual components namely the wheel brake, transmission and overrun mechanism are designed as a system to ensure effective performance.

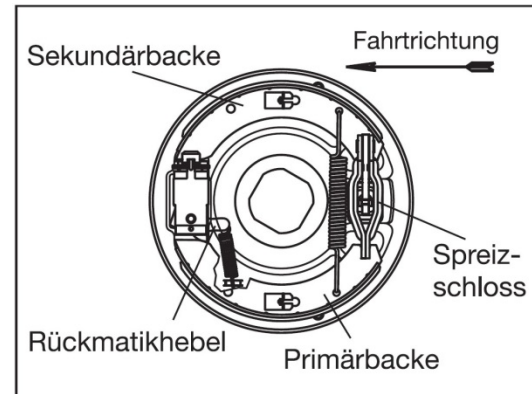

Quelle: BPW

Parking brake lever

The brake system operates fully automatically and requires no specific handling procedures. Please comply with the following information when operating the parking brake lever:

Firmly pull the parking brake lever beyond the dead centrepoint (min. 3 teeth). The parking brake lever will be retensioned automatically by the gas spring if the trailer has a tendency to roll backwards. Compressing the drawbar with the towing vehicle makes operation of the parking brake lever easier. In this case, the wheel brake is normally pushed into the automatic reversing mechanism and the parking brake lever can be pulled up to the end position (12 teeth).

The towing vehicle must be connected to the parking brake lever by means of a breakaway cable. In the event of the trailer breaking away from the towing vehicle, the trailer is stopped by the parking brake lever in conjunction with the breakaway cable.

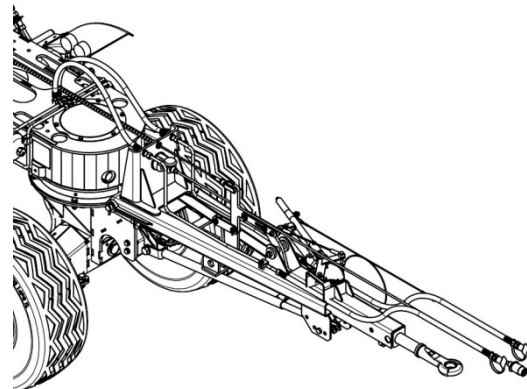

Automatic Reversing Mechanism

Adjusting the wheel brakeS 3006-7 RAZG

Secure the trailer to prevent it moving and jack it up. Release the towing linkage to the overrun device and to the parking brake lever. Using the aid (< 4 mm Ø pin), lock the swivel cam of the wheel brake from the outside by inserting the pin through the locking hole (insert to a depth of min. 50 mm). With the aid of a spanner, tighten the adjusting nuts (item C) on the adjusting pin (item B) at the wheel brakes until the wheel can no longer turn in the driving direction. Turn back the adjusting pin until the braking effect can no longer be felt when turning the wheel forwards.

Caution: The wheel brake should only be readjusted at the adjusting pin! Reconnect the towing linkage to the overrun mechanism and adjust so that it is free of play. For this purpose, the drawbar of the overrun mechanism must be completely extended and reversing must lever rest on the drawbar.

As a check, lightly apply the parking brake and check that the braking torque (in the driving direction) is the same at the wheels on the left and right. Check that the individual brakes take effect at the same time.

Caution: Remove the locking pin (< 4 mm Ø pin) from the swivel cam!

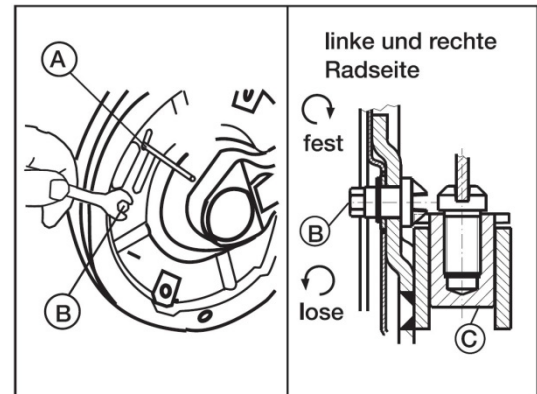

Quelle: BPW

Automatic Reversing Mechanism

Basic setting of the wheel brake

The basic setting is carried out at the factory prior to delivery. The basic setting only requires readjustment after the drawbar or parts of the mount assembly have been replaced. Proceed as follows:

Release the towing linkage to the overrun device and the parking brake lever. Remove pin (Fig. 2, item D) by releasing the retaining clips. Using the aid (Fig. 1, item A, < 4 mm Ø pin), lock the swivel cam of the wheel brake from the outside by inserting the pin through the locking hole (insert to a depth of min. 50 mm). With the aid of a spanner, tighten the adjusting nuts (Fig. 1, item C) on the adjusting pin (Fig. 1 item B) at the wheel brakes until the wheels can no longer turn in the driving direction. When making the initial setting, make sure that the holes in the yoke ends (Fig. 2, item E) exactly line up with the holes in the steering lever and the towing linkages are connected without play. Now reinstall the pins (Fig. 2, item D) and secure with clips.

Turn back the adjusting pin until the braking effect is no longer felt when turning the wheel forwards.

Caution: The wheel brake should only be readjusted at the adjusting pin!

Reconnect the towing linkage to the overrun mechanism and adjust so that it is free of play. For this purpose, the drawbar of the overrun device must be completely extended and the reversing lever rest on the drawbar. With the parking brake lightly applied in the forwards direction, check the position of the brake lever of the mount assembly (angle position approx. 40°, Fig. 3). Readjust the brake setting, if necessary. Check that the brakes respond uniformly when the parking brake is lightly applied. Readjust the brake setting, if necessary.

Caution: Remove locking pin (< 4 mm Ø pin) from the swivel cam!

With the parking brake lightly applied in the reverse direction, check the position of the brake lever in relation to the mount assembly (brake lever parallel to the axle beam). Readjust the brake setting, if necessary.

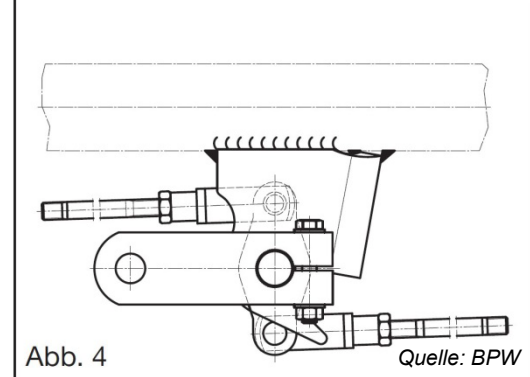
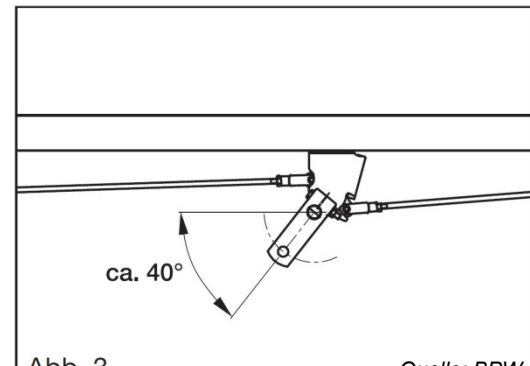
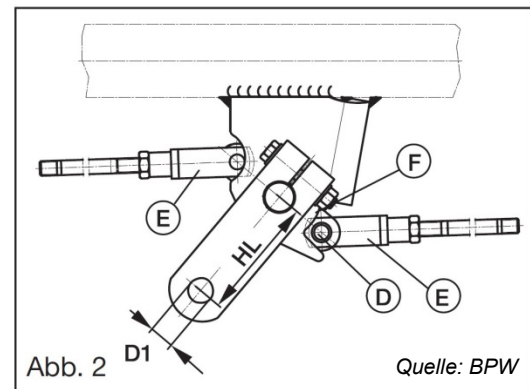
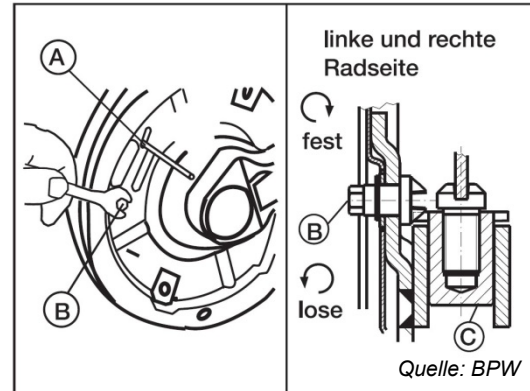

Axle Bearing

Checking the bearing play in the wheel hub

To check the bearing play in the wheel hub, raise the axle until the tyres are clear of the ground. Release the brake, place a lever between the tyre and the ground, and check for play.

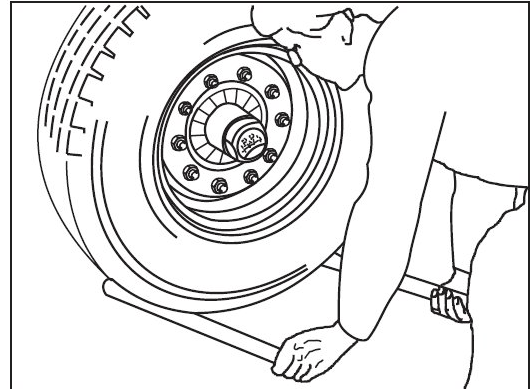

Quelle: BPW

Adjusting the bearing play

If you can feel play in the bearing:

Nachstellen der Kegelrollenlager an den Hinterachsen der Typen SWW500, SWW510, SWW550 und SWW560; bei den Typen SWW400HM, SWW450HM, SWW400L und SWW450L; bei allen 1-Achsern, sowie X2 und X6.

1. Remove the bearing cap, or hub end-cap.
2. Remove the split pin from the wheel nut.
3. Tighten the wheel nut while turning the wheel, until the turning of the hub is slightly impeded.
4. Turn back the axle nut to the nearest possible splint pin hole. If already in line, turn back to the next hole (maximum of 30°).
5. Insert the split pin and gently bend it over.
6. Refill the bearing cap with a little special long lifegrease (e.g. BPW ECO-Li 91) and tap or screw it back into the wheel hub

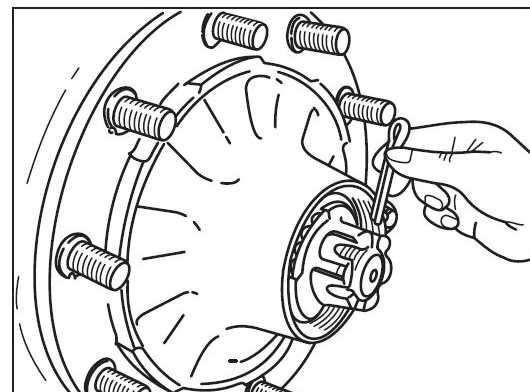

Quelle: BPW

Caution!

To sharp focus will cause bearing damage.



Wheel bearings

Replacing the compact bearings

Replacing the compact bearings on the front axle on SWW500, SWW510, SWW550 and SWW560 and on SWW400, SWW450, SWW460 and SWW460HM models.

The wheel bearings are absolutely maintenance-free. Should you notice a very loud noise on the wheels or substantial play in a bearing, replace the entire bearing. It is not possible to disassemble the sealed bearings.

1. Remove the wheel bearing dust cap (5)
2. Remove the flanged nut (4)
3. Remove the hub or brake drum (1). The compact bearing (2) sits inside the hub.
4. Remove the seeger circlip ring (3)
5. Remove the compact bearing (2)
6. Fit the new compact bearing (2); fit the seeger circlip ring (3)
7. Replace the hub or brake drum (1) on the steering knuckle
8. Fit a new flanged nut (4). The flanged nut needs replacing whenever the brake drum is removed.
9. Torque the flanged nut (4) to 280 Nm
10. Tap the dust cup on to the hub (5)

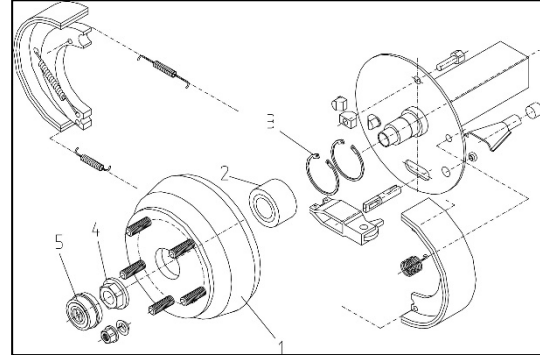

Source: Nieper

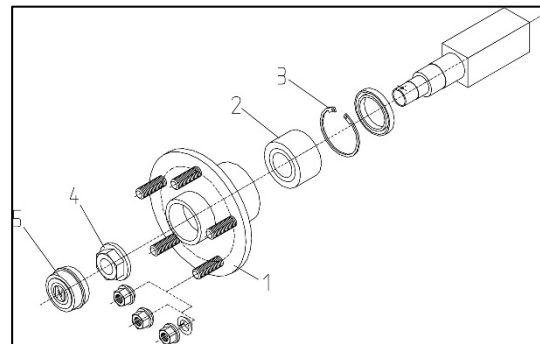

Source: Nieper

Wheels

Retighten wheel nuts

Check wheel nuts for tight fit.

Check that the wheel nuts are tight after the first laden journey, likewise after each wheel change and every 500 hours in operation or annually. Use a torque wrench to tighten the wheel nuts to the correct torque setting, as shown in the sticker (310Nm (228 ft.lb)).

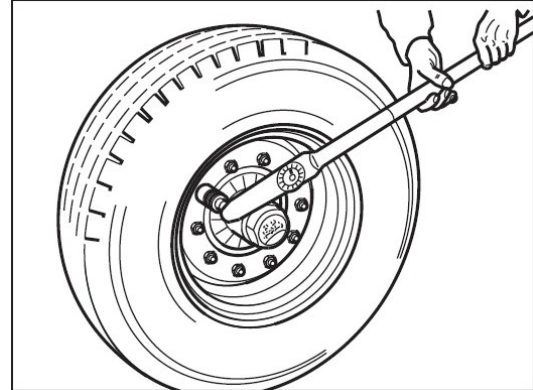

Quelle: BPW

Tighten the wheel nuts in the proper sequence.



Tightening torques for wheel bolts

| Type | Thread size | Tightening torque |
|-----------------------------------|----------------------|-------------------|
| SWW100 to SWW360 | M18x1,5 | 310 Nm |
| SWW450, SWW460 | M12x1,5 | 95 Nm |
| SWW450, SWW 460 | M14x1,5 | 125 Nm |
| SWW500, SWW510, SWW550, SWW560 | M14x1,5 (front axle) | 125 Nm |
| | M18x1,5 (rear axle) | 310 Nm |
| SWW-X2, SWW-X6 | M18x1,5 | 310 Nm |

Wheels

Tyres

Ensure the tyres have sufficient tread depth. The minimum tread depth should be 1.6 mm. Replace cracked or damaged tyres.

Use tyres and wheels that are specified for the header transporter.

Tyre pressure

The tyre pressure should be 5 bar on the 25km/h header transporters.

Increase the pressure to 7.1 bar on 40km/h models or when travelling long distances.

7,1 bar

Electrical Installation

Pin allocation DIN/ISO 1724 (7-Pin Connector)

| | |
|-------|--------|
| L/1 | yellow |
| 54g/2 | blue |
| 31/3 | white |
| R/4 | green |
| 58R/5 | brown |
| 54/6 | red |
| 58L/7 | black |

Maintenance

General service and maintenance instructions

Any service and maintenance work must be carried out by trained staff who are familiar with the mode of operation of the machine.

The engine of the towing vehicle must be shut off and all ancillaries must have come to stop before any service, maintenance or repair work can be carried out.

- Visually inspect the header transporter for damage, deformations and cracks in structural parts.
- Check the tyres for wear. The minimum tread depth is 1.6 mm and must not be undercut. Damaged tyres must be replaced.
- Check the lights for proper function.
- Replace defective components.

The manufacturer accepts no liability if the instructions on service and maintenance are not observed. The manufacturer neither accepts liability for any damage caused by improper service and maintenance.



Cleaning the machine regularly helps to preserve its paint finish. Cleaning the contaminated parts fairly promptly helps to prevent fading and corrosion. It is best to repair any damage to the paint coat immediately.

CAUTION! Avoid using a pressure washer to clean those areas that contain bearings and hydraulic components. A pressure washer that is set to an excessive pressure is at risk of damaging the paint finish.



Maintenance

Wear suitable protective clothing!

Disconnect the driveline before working on the mechanical drive components.

Always disconnect the electric line before working on the electrical system.

Maintenance

After the first 10 operating hours

After an initial period of driving, the brake linings will have adapted to the brake drum and the components of the transmission device will have settled. The resulting play must be taken up by readjustment.

Proceed as follows:

7. Adjust the wheel brake as described in
▶ chapter "Adjusting the brake system".
8. Then check the amount of overrun travel used by braking the vehicle to a stop. It should not exceed 50-60% of the maximum overrun range. If this is the case, repeat the wheel brake adjustment procedure
9. Now check whether the towing vehicle can easily push back the trailer. If the trailer is braked too much, the setting at the wheel brake should be released a little.
10. On completion of adjustment, ensure all lock nuts are firmly tightened.

Every 200 operating hours

Check the function of the brake system. Carry out the wheel brake adjustment procedure as described in ▶ chapter "Adjusting the brake system". Now proceed from point 2 as described under "after 10 operating hours".

Check the brake lining thickness. For this purpose, remove the plastic plug from the inspection hole in the brake anchor plate and carry out a visual inspection. New brake shoes must be fitted if the brake linings are damaged or less than 2 mm thick. Also replace any worn or damaged parts (springs, brake shoe expander, etc.).

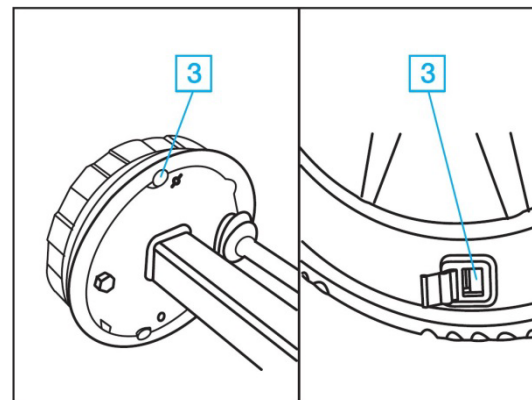

Source: BPW

Quarterly

Lubricate all bearing points at least every three months.



Maintenance

Every 1000 hours in operation (latest annually)

Changing the grease in the wheel hub bearing

Jack up and secure the trailer and release the brakes. Remove the wheels and bearing caps. Remove the split pin and unscrew the axle nut. Using a suitable retractor, withdraw the wheel hub with the brake drum, the roller bearings and the sealing elements from the axle stub. Label or mark the wheel hubs and bearing cages so that they do not become mixed up during re-assembly. Clean the brake, check for wear, make sure that it is intact and operates correctly, and replace any worn parts.

The inside of the brake must be kept free of grease and dirt. Clean the wheel hubs thoroughly on the inside and the outside, removing every trace of old grease. Clean the bearings and seals thoroughly (diesel oil) and check to ensure that they are suitable for re-use. Lightly grease the bearing seats before fitting the bearings, and then assemble all the parts in the reverse order. Carefully drive the parts into place on the bearing shells, without tilting or damaging them. Coat the bearings, the wheel hub cavity between the bearings and the bearing cap with grease before re-assembly. The quantity of grease should fill approximately a quarter to a third of the space in the assembled hub. Fit the axle nut and adjust the bearings and the brake.

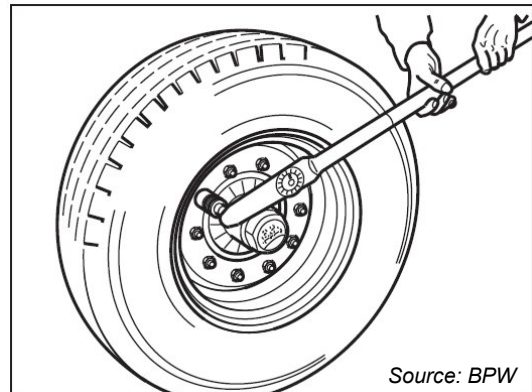
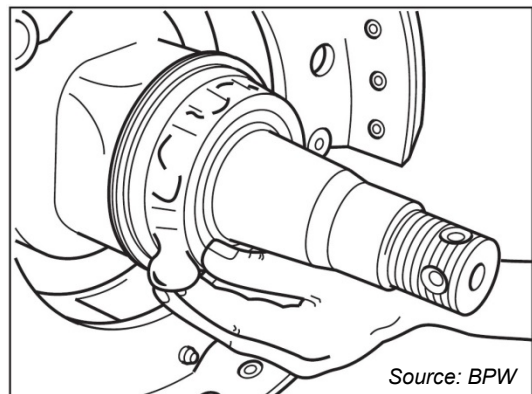
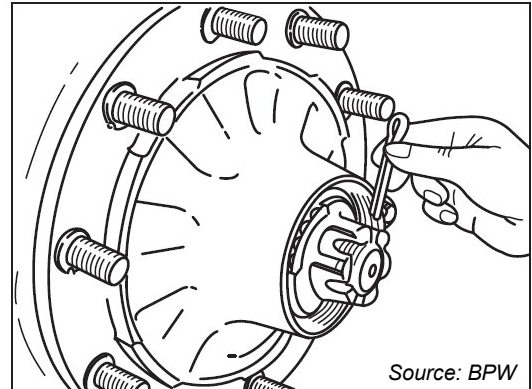

Finally, check that everything is in working order and carry out a suitable test drive, correcting any faults that you may discover. The wheel hubs must only be lubricated with special long life grease (ECO Li 91) with a drop point above 190°C. using the wrong grease or excessive quantities may lead to damage. Damage can be caused by the mixing of lithium-based grease with sodium-based grease, because of incompatibility.



Lubricants and oils

The service intervals given below are based on an average utilisation of the machine. Reduce these service intervals, if the machine is used at above-average levels.

The specific lubricant to be used is indicated by a symbol. These symbols are explained in the table below.

| Type of service | Type of lubricant | Comment |
|--------------------------------------------------------------------------------------------------------|-------------------------------------------|-------------------------------------------------------------------------------------------------------------------|
| Grease  | Multi-purpose grease | Grease nipples: Apply about two shots of grease from the grease gun. Remove any excessive grease from the nipple. |
| Lubricate  | Vegetable oils unless specified otherwise | Sliding surfaces: Apply a thin film of the oil with a brush or a spray can. Remove any excessive oil. |
| Oil  | | Apply a uniform film of oil on the surface. |

CAUTION!

Lubricants are a hazard to the environment if stored and disposed of incorrectly.

- Store the lubricants in suitable bins and in accordance with the legal requirements.
- Dispose of used lubricants in accordance with the legal regulations.



IMPORTANT!

Immediately replace missing grease nipples. Clean the grease nipples thoroughly before greasing them.



Lubricants and oils

Grease

Select the grease according to its NLGI grade and the anticipated outside temperatures in which the machine will be operated until the next service.

The use of the following greases is recommended:

Shell Alvania Grease RL 2, Gadus S2 V100 2, John Deere Grease-Gard Premium, Petronas Grease CA 00

Other greases can also be used provided they meet the required specification.

Lubricate Bowden cables with grease gun oils, do not use grease.

Service points

Service points on the drawbar and the front axle

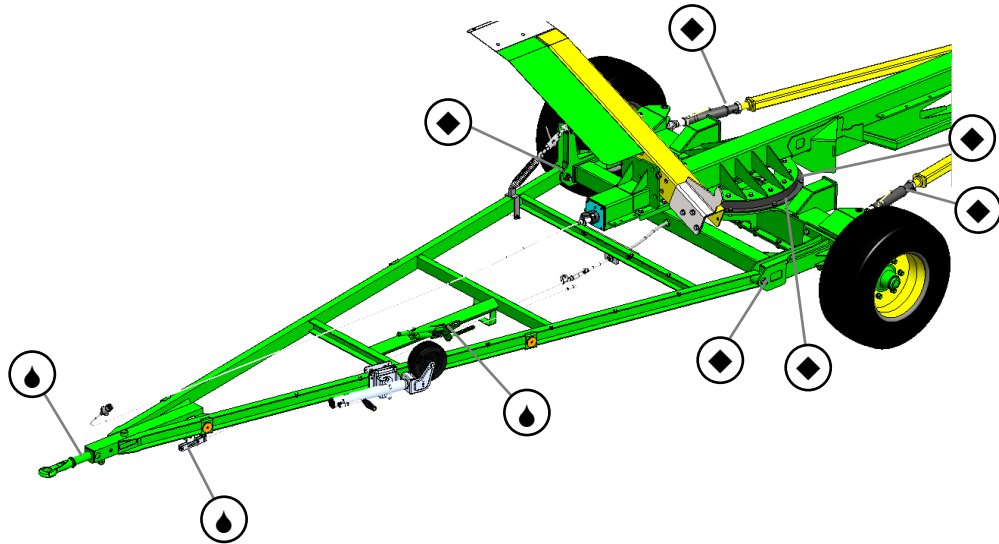

The hitch ring shaft is serviced with grease, penetrating oil or similar

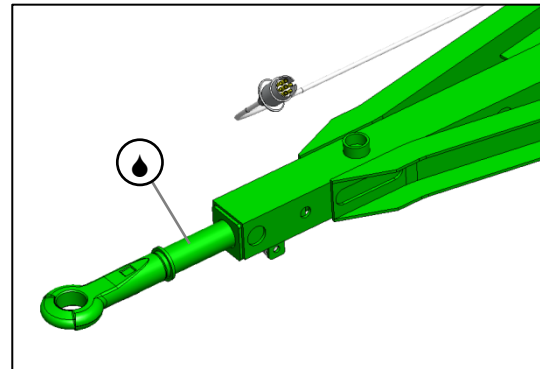

The hitch ring shaft and the linkage joints are serviced with grease, penetrating oil or similar

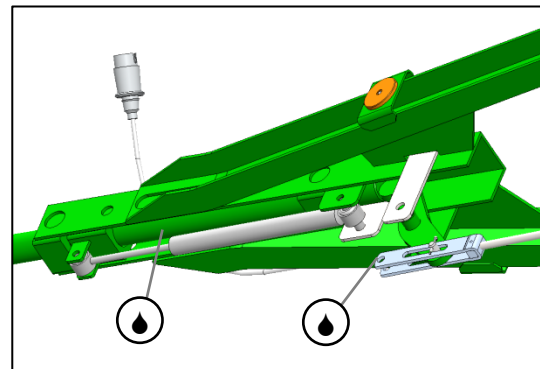

Service points

The joints on the hand brake lever are serviced with grease, penetrating oil or similar

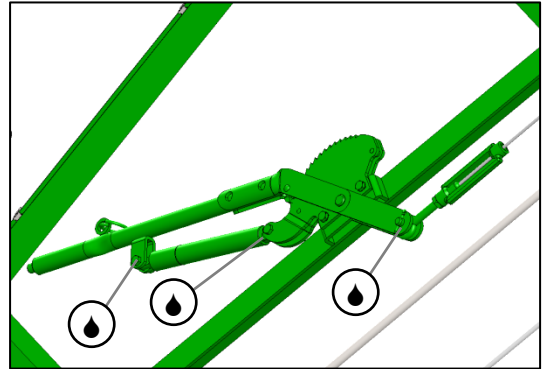

Grease nipple on the drawbar bearing

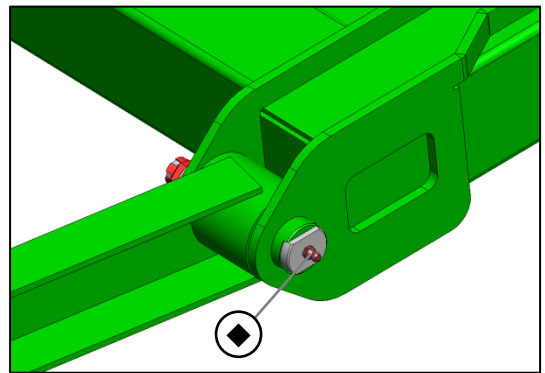

Grease nipple on the drawbar bearing

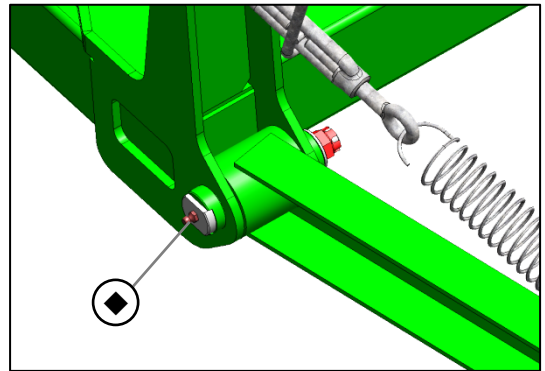

Three grease nipples on the circumference of the turntable. The turntable is greased.

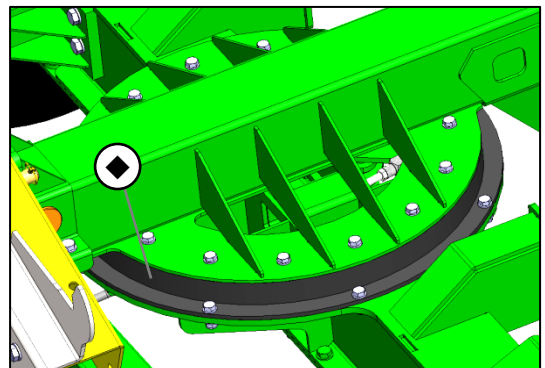

Service points

Grease nipples on the brake shaft bearing

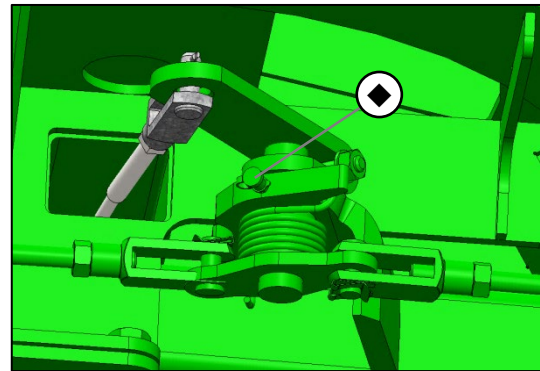
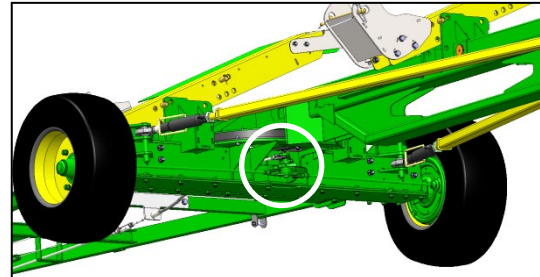

Grease nipples on the threads of the left / right turnbuckle

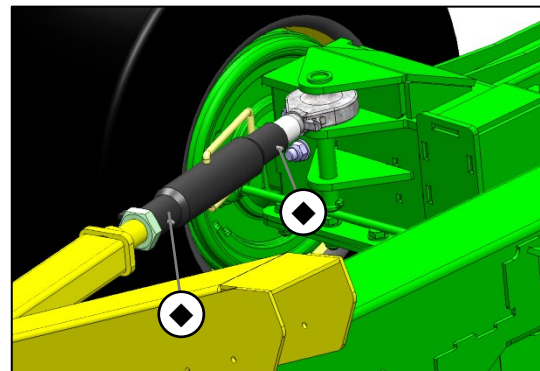
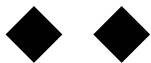

Grease nipples on the threads of the left / right turnbuckle

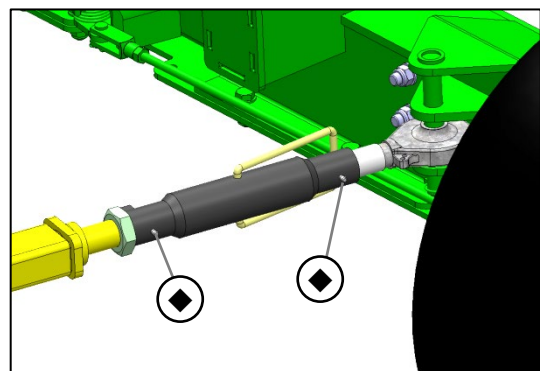
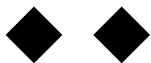

Service points

Service points on the rear axle

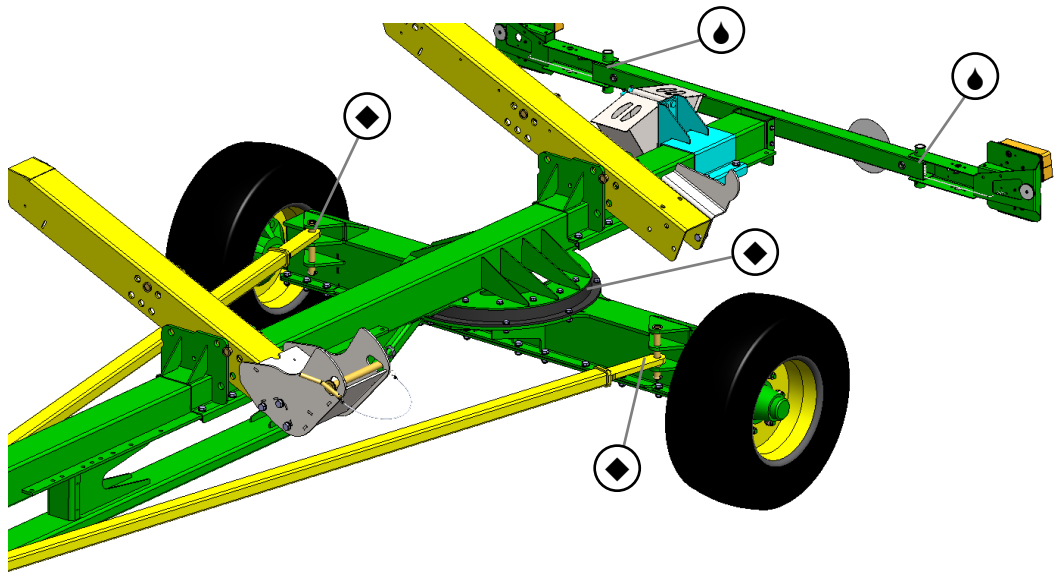

Three grease nipples on the circumference of the turntable. The turntable is greased.

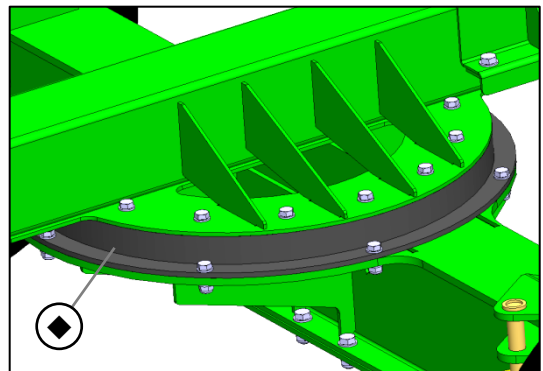

Lubricate the left-hand side push-pullrod connection on the steering system

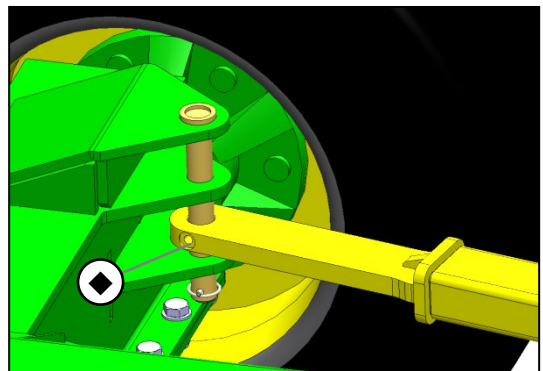

Service points

Lubricate the right-hand side push-pullrod connection on the steering system

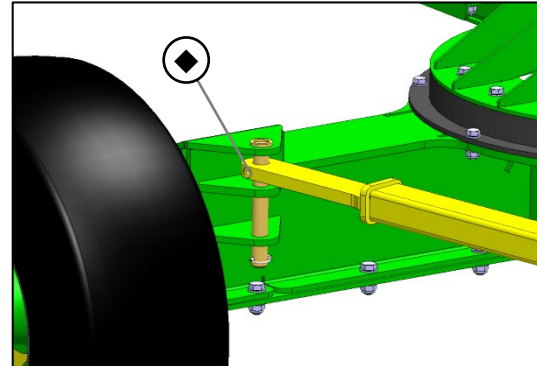

Apply penetrating oil or similar to the bearings on both light holders

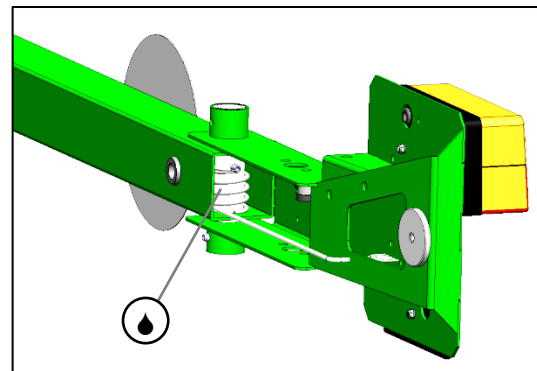

Torques for Metric Bolts

| Bolts | Grade 4.8 | | | | Grade 8.8 oder 9.8 | | | | Grade 10.9 | | | | Grade 12.9 | | | |
|-------|-----------|-------|------|-------|--------------------|-------|------|-------|------------|-------|------|-------|------------|-------|------|-------|
| | Oiled | | Dry | | Oiled | | Dry | | Oiled | | Dry | | Oiled | | Dry | |
| Size | N•m | lb-in | N•m | lb-in | N•m | lb-in | N•m | lb-in | N•m | lb-in | N•m | lb-in | N•m | lb-in | N•m | lb-in |
| M6 | 4,7 | 42 | 6 | 53 | 8,9 | 79 | 11,3 | 100 | 13 | 115 | 16,5 | 146 | 15,5 | 137 | 19,5 | 172 |
| M8 | 11,5 | 102 | 14,5 | 128 | 22 | 194 | 27,5 | 243 | 32 | 23,5 | 40 | 29,5 | 37 | 27,5 | 47 | 35 |
| M10 | 23 | 204 | 29 | 21 | 43 | 32 | 55 | 40 | 63 | 46 | 80 | 59 | 75 | 55 | 95 | 70 |
| M12 | 40 | 29,5 | 50 | 37 | 75 | 55 | 95 | 70 | 110 | 80 | 140 | 105 | 130 | 95 | 165 | 120 |
| M14 | 63 | 46 | 80 | 59 | 120 | 88 | 150 | 110 | 175 | 130 | 220 | 165 | 205 | 150 | 260 | 190 |
| M16 | 100 | 74 | 125 | 92 | 190 | 140 | 240 | 175 | 275 | 200 | 350 | 255 | 320 | 235 | 400 | 300 |
| M18 | 135 | 100 | 170 | 125 | 265 | 195 | 330 | 245 | 375 | 275 | 475 | 350 | 440 | 325 | 560 | 410 |
| M20 | 190 | 140 | 245 | 180 | 375 | 275 | 475 | 350 | 530 | 390 | 675 | 500 | 625 | 460 | 790 | 580 |
| M22 | 265 | 195 | 330 | 245 | 510 | 375 | 650 | 480 | 725 | 535 | 920 | 680 | 850 | 625 | 1080 | 800 |
| M24 | 330 | 245 | 425 | 315 | 650 | 80 | 820 | 600 | 920 | 680 | 1150 | 850 | 1080 | 800 | 1350 | 1000 |
| M27 | 490 | 360 | 625 | 460 | 950 | 700 | 1200 | 885 | 1350 | 1000 | 1700 | 1250 | 1580 | 1160 | 2000 | 1475 |
| M30 | 660 | 490 | 850 | 625 | 1290 | 950 | 1630 | 1200 | 1850 | 1350 | 2300 | 1700 | 2140 | 1580 | 2700 | 2000 |
| M33 | 900 | 665 | 1150 | 850 | 1750 | 1300 | 2200 | 1625 | 2500 | 1850 | 3150 | 2325 | 2900 | 2150 | 3700 | 2730 |
| M36 | 1150 | 850 | 1450 | 1075 | 2250 | 1650 | 2850 | 2100 | 3200 | 2350 | 4050 | 3000 | 3750 | 2770 | 4750 | 3500 |

The tightening torques given are guideline values. Do NOT use these values if a different torque or another securing method is specified for a specific application. For stainless steel bolts and nuts for stirrup bolts, see specific instructions. Tighten locking nuts with plastic insert or edge-raised steel locking nuts to the corresponding torque for dry bolts and nuts given in the table unless otherwise instructed.

Shear pins are designed to break at a certain load. When replacing shear pins, use only pins of the same grade. When replacing bolts and nuts, make sure that equivalent parts of the same or a higher grade are used. Tighten higher-grade nuts and bolts to the same torque as the originally used parts. Make sure that the thread is clean and the bolts correctly fitted. If possible, oil normal and galvanised nuts and bolts (except for locking nuts and wheel studs or nuts) unless specified otherwise for the specific application.

“Oiled” means that a lubricant, such as engine oil, is applied to the bolts or that phosphatized or oiled bolts with a size from M20 are used.

“Dry” means the use of normal or galvanised bolts without lubrication or bolts with a size between M6 and M18 that are zinc-coated.

Malfunctions and Remedies

| Malfunction | Cause | Remedy |
|-------------------------------------------------------------|---------------------------------------------|------------------------------------------------------|
| Poor brake response | The brake pads are not broken in | Apply the brake repeatedly to improve brake response |
| | The pullrod retracts all the way | Adjust the pullrod |
| | Excessive friction | Check the brake force transmitting system |
| Braking is difficult when reversing | The brake linkage is set too rigid | Re-adjust the brake linkage |
| Poor hand brake effect | The brake pads are not broken in | Apply the brake repeatedly to improve brake response |
| | Excessive friction | Check the brake force transmitting system |
| | The hand brake is not set up properly | Re-adjust the hand brake |
| The transporter is not tracking properly (2 steering axles) | The steering system is not set up correctly | Re-adjust the system |
| | The push-pullrod or tie rod is deformed | Replace the rod |

Technical data

Double-axle-steer header transporters for ZÜRN 700PF headers

| Model | Total length [mm] | Total width [mm] | Maximum height [mm] | Track width [mm] | Kerb weight [kg] | GVWR [kg] | Front axle load [kg] | Rear axle load [kg] |
|--------------|----------------------|---------------------|------------------------|---------------------|---------------------|--------------|-------------------------|------------------------|
| SWW-X2-725PF | 11,850 | 2,550 | 1,700 | 2,270 | 1,850 | 6,000 | 3,200 | 3,200 |
| SWW-X2-730PF | 13,670 | 2,550 | 1,700 | 2,270 | 1,895 | 8,000 | 4,200 | 4,200 |
| SWW-X2-735PF | 15,170 | 2,550 | 1,700 | 2,270 | 1,960 | 8,000 | 4,200 | 4,200 |

Double-axle-steer header transporters for John Deere RA (600R) headers

| Model | Total length [mm] | Total width [mm] | Maximum height [mm] | Track width [mm] | Kerb weight [kg] | GVWR [kg] | Front axle load [kg] | Rear axle load [kg] |
|-------------|----------------------|---------------------|------------------------|---------------------|---------------------|--------------|-------------------------|------------------------|
| SWW-X2-625R | 11,850 | 2,550 | 1,700 | 2,270 | 1,850 | 6,000 | 3,200 | 3,200 |
| SWW-X2-630R | 13,670 | 2,550 | 1,700 | 2,270 | 1,895 | 8,000 | 4,200 | 4,200 |
| SWW-X2-635R | 15,170 | 2,550 | 1,700 | 2,270 | 1,960 | 8,000 | 4,200 | 4,200 |

Technical data

Double-axle-steer header transporters for John Deere XA (600X) headers

| Model | Total length [mm] | Total width [mm] | Maximum height [mm] | Track width [mm] | Kerb weight [kg] | GVWR [kg] | Front axle load [kg] | Rear axle load [kg] |
|-------------|----------------------|---------------------|------------------------|---------------------|---------------------|--------------|-------------------------|------------------------|
| SWW-X2-625X | 11,850 | 2,550 | 1,500 | 2,270 | 2,030 | 6,000 | 3,200 | 3,200 |
| SWW-X2-630X | 13,670 | 2,550 | 1,500 | 2,270 | 2,190 | 8,000 | 4,200 | 4,200 |
| SWW-X2-635X | 15,170 | 2,550 | 1,500 | 2,270 | 2,260 | 8,000 | 4,200 | 4,200 |

Double-axle-steer header transporters for John Deere RDF (600/700FD) headers

| Model | Total length [mm] | Total width [mm] | Maximum height [mm] | Track width [mm] | Kerb weight [kg] | GVWR [kg] | Front axle load [kg] | Rear axle load [kg] |
|--------------|----------------------|---------------------|------------------------|---------------------|---------------------|--------------|-------------------------|------------------------|
| SWW-X2-630FD | 13,670 | 2,550 | 1,500 | 2,270 | 2,245 | 8,000 | 4,200 | 4,200 |
| SWW-X2-635FD | 15,170 | 2,550 | 1,500 | 2,270 | 2,310 | 8,000 | 4,200 | 4,200 |

General terms of guarantee

Zürn Harvesting GmbH & Co. KG, Kapellenstraße 1, D-74214 Schöntal-Westernhausen (hereinafter “**Zürn Harvesting**”) hereby certifies for each customer who has purchased a new Zürn Harvesting machine from an authorised dealer that the materials and workmanship of this machine are guaranteed under the conditions specified below, providing that the machine is put into operation and maintained in accordance with the specifications in the operating instructions.

Duration of the guarantee

The guarantee period is one year from delivery of the machine by Zürn Harvesting and is valid for up to 500 operating hours within this period. The replacement of individual parts or repair will not prolong the above guarantee period for the machine.

Scope of the guarantee

The guarantee embraces only the reimbursement or repair of the parts and reimbursement of work time required in order to effect the repair, based on the repair times allowed by Zürn Harvesting, under the prerequisite that the fault was determined by our technical customer service department and was acknowledged by Zürn Harvesting to be attributable to faulty materials or workmanship. Replaced parts will become the property of Zürn Harvesting. The customer must allow services received from the vendor/dealer under warranty to be credited to the guarantee.

The guarantee does not cover any further claims against Zürn Harvesting. This means in particular that travel and transport costs will not be reimbursed, nor will Zürn Harvesting be liable for consequential damage, such as loss of harvest or losses of income.

Limitations of the guarantee

The guarantee does not apply to defects or faults that are attributable to:

- usual wear and tear;
- failure to heed operating, storage or transport instructions contained in the operating manual;
- use other than as intended, inadequate maintenance, inexperienced operation or excessive use;
- damage caused to the machine or its equipment caused during transportation or loading; machines, equipment and parts are shipped at the risk of the recipient;
- external influences on the machine, e.g. third-party damage, weathering or other natural occurrences;
- circumstances that were known to the buyer at the time of purchase.

The guarantee will be rendered null and void if technical modifications are made to the machine without the written consent of Zürn Harvesting or if spare parts other than original Zürn Harvesting spare parts are installed and/or if repairs were not carried out by an authorised dealer. The guarantee is likewise voided if the machine was not put into service for the first time by the dealer in accordance with the instructions of Zürn Harvesting.

General terms of guarantee

Assertion of the guarantee

The terms of the guarantee are dependent upon precise observance of the following regulations by both the dealer and the purchaser:

- The guarantee card (machine card) completed by the dealer and customer must be returned to Zürn Harvesting by post or e-mail as soon as the machine has been delivered to the customer.
- Applications for guarantee claims must be formulated on the corresponding Zürn Harvesting form and presented to Zürn Harvesting by the dealer within one calendar month of discovery of the defect/fault.
- The application must be completed legibly and must contain the following information:
 - Name, address and dealer customer number
 - Name and address of the purchaser
 - Exact machine type and designation
 - Complete serial number of the machine
 - Date of delivery to the dealer and to the purchaser
 - Date of the claim
 - Number of operating hours or acreage harvested by the machine
 - Exact description of the damage and information regarding the probable cause
 - Quantity, item numbers and description of damaged parts

The parts reported as damaged must be returned to Zürn Harvesting free of charge for appraisal, complete with a copy of the guarantee claim application. Any costs incurred for returning the parts replaced or repaired will be borne by the sender.

If the guarantee claim application is refused, the dealer or the customer has a period of 15 days, starting from the day the Zürn Harvesting decision was received, to demand return of the damaged parts. Once this period has elapsed, the parts will be disposed of.

Additional clauses

Claims under the guarantee may not be transferred to third parties without the prior, written consent of Zürn Harvesting.

The dealer has neither the right nor the authority to make declarations or to enter into a commitment etc., whether express or implied, in the name of Zürn Harvesting.

The technical support for repair of the machine given by Zürn Harvesting or their representatives excludes any further liability whatsoever by Zürn Harvesting and has no influence whatsoever on the existing terms of guarantee.

Zürn Harvesting reserves the right to modify the design of the machine without prior notice. It is not obliged to transfer such modifications to machines which have already been sold or are in use.

Furthermore, due to the rapid development of the state of the art, no guarantee can be given for the machine descriptions contained in these operating instructions or other technical leaflets and data sheets.

EG- Konformitätserklärung

EG- Konformitätserklärung nach Maschinenrichtlinie 2006/42/EG

Bitte sorgfältig aufbewahren, jedoch nicht im Fahrzeug

EU CERTIFICATE OF CONFORMITY According to Machinery Directive 2006/42/EG

Please keep safely, not inside the vehicle

| | | |
|-----------------------------------------------------------------------------------------------------------------------------------------------------------------------------------------------------------------------------------------------------------------------------------------------------------------|--------------------------------------------------------------------------------------------------------------------------------|---------------------------------|
| Hiermit bestätigt die <i>Hereby declares</i> | Zürn Harvesting GmbH & Co. KG | |
| in alleiniger Verantwortung dass das landwirtschaftliche Anbaugerät <i>the full responsibility for the agricultural implement</i> | Fabrikmarke <i>Brand</i> | Zürn Harvesting GmbH |
| | Typ <i>Type</i> | SWW X2 |
| genehmigt in <i>approved in</i> | Schoental | |
| am <i>on</i> | 19.01.2017 | |
| durch den <i>by the</i> | Hersteller / manufacturer | |
| den grundlegenden Sicherheits- und Gesundheitsanforderungen der Richtlinie 2006/42/EG entspricht. <i>to full fill the complete safety- and health requirements according to machinery directive 2006/42/EG.</i> | | |
| Zur sachgerechten Umsetzung der in den EU- Richtlinien genannten Sicherheits- und Gesundheitsanforderungen wurden folgende Normen herangezogen: <i>For proper implementation according to the EU- Directives for health and safety requirements, the following standards were used:</i> | DIN EN ISO 4254-1 (06/06) DIN EN 745 (08/99) | |
| Geschehen zu <i>Done at</i> | Schoental | |
| am <i>on</i> | 05/03/17 | |
|  |  Rolf Zürn Geschäftsführer, CEO | |

Zürn Harvesting GmbH & Co. KG
Eichenstraße 27
D-74747 Ravenstein-Merchingen

Tel.: +49 6297 92885-0
Fax: +49 6297 92885-19
E-Mail: info@zuern-harvesting.de

Internet: www.zuern-harvesting.de