

PremiumFlow

Cutting Platform

Operator's Manual

PremiumFlow

Cutting Platform

Model:	
Serial Number:	
Year of Production:	

Introduction

Foreword

INTENDED USE: This cutting platform is designed solely for use in customary agriculture or similar operations. Use in any other way is considered as contrary to the intended use. The manufacturer accepts no liability for damage or injury resulting from misuse, and these risks must be borne solely by the user. Compliance with and strict adherence to the conditions of operation, service and repair as specified by the manufacturer also constitute essential elements for the intended use.

READ THIS MANUAL carefully to learn how to operate and service your machine correctly. Failure to do so could result in personal injury or equipment damage. This manual and the safety signs on your machine may also be available in other languages (see your John Deere dealer to order).

THIS MANUAL SHOULD BE CONSIDERED a permanent part of your machine and should remain with the machine when you sell it.

MEASUREMENTS IN THIS MANUAL are given in metric. The U.S. equivalents are still quoted, however. Use only correct replacement parts and fasteners. Metric and inch fasteners may require a specific metric or inch wrench.

RIGHTHAND AND LEFTHAND sides are determined by facing in the direction of forward travel.

WRITE SERIAL NUMBERS in the proper table in the beginning of this manual. Please note all numbers exactly. In the event of theft, these numbers may prove vital in tracing your property. Your dealer also needs these numbers when you order parts. File the identification numbers in a secure place off the machine.

BEFORE DELIVERING THIS MACHINE, your dealer performed a predelivery inspection. After operating for the first 20 to 50 hours, schedule an aftersale inspection with your dealer to ensure best performance.

THIS CUTTING PLATFORM SHOULD BE OPERATED serviced and repaired only by persons familiar with all its particular characteristics and acquainted with the relevant safety rules (accident prevention). The accident prevention regulations, all other generally recognized regulations on safety and occupational medicine and the road traffic regulations must be observed at all times. Any arbitrary modifications carried out on this combine will relieve the manufacturer of all liability for any resulting damage or injury.

Contents

Introduction	2
Contents	3
Predelivery Inspection	5
Identification View	6
Safety	7
Safety Decals	14
Adjusting Cutting Platform	15
Attaching and Detaching	27
Transporting	31
Operating the Platform	32
Basic Positions for Different Crops	33
Decal Bandgeschwindigkeit	34
Attaching Side Knife for Oil Seed Rape	35
Double Speed Belt-Drive	36
Fast-change system chain sprocket belt speed	38
Positioning of Side Knife for Oil Seed Rape	39
Adjusting Reel Support for Oil Seed Rape	40
Adjusting Auger Height Hydraulically	40
Adjusting Rear Stripper (Oil Seed Rape-Stripper) (618-630)	45
Safety Appliances/Devices	47
Skid Plates with HEADERTRAK	48
Basic Setting of Reel	49
Crop Dividers	51
Installing Lifters	54
Knife Protection Guard	55
Adjusting Angle of Tilt of the Cutting Platform	55
Adjusting Auger Height	56
Adjusting Auger Finger Timing	57
Adjusting Auger Fore/Aft	58
Adjusting Rear Stripper	59
Adjusting Auger Chain	59
Chain Tension of Belt Drive	60
Auger Floor Stripper Extension	62
Auger Anti-Wrap Shields	62
Cleaning underneath the Belt Body	63
Lubricants, Oil and Capacities	65
Lubrication Charts, Periodic Service	67
Table of Service	68
Troubleshooting	69
Service	73
Adjusting Reel Speed Ratio Sensor	73
Replacing Cutterbar Knife	74
Aligning Knife Head and Knife Drive Alignment	79
Replacing Knife Sections	83
Aligning Guards	84
Replacing Auger Fingers and Retainers	84
Remove and Install Knife Drive Belt and Checking the Tension	86
Adjusting Skid Plates for Automatic Header Control	87
Rephasing Reel Lift Cylinders	88
Bleeding the Reel Lift Cylinders	88
Removing the Belt Body	89
Removing the Belt Body	90
Dismantling the Belt Body	91
Storage of the Cutting Platform	96
Beginning of Season Service	97

Specifications	98
EC DECLARATION OF CONFORMITY	99
According to Machinery Directive 2006/42/EEC	99
Metric Bolt and Screw Torque Values	100
Unified Inch Bolt and Screw Torque Values	101
Serial Number	102
Serial Number Plate	102
Subject Index	103

Predelivery Inspection

The following checks, adjustments and service jobs were performed prior to delivery of the machine:

Predelivery Inspection

- | | |
|---|---|
| <input type="checkbox"/> 1. Is cutterbar drive gear case oil level correct? | <input type="checkbox"/> 7. Is the cutting platform lubricated? |
| <input type="checkbox"/> 2. Are all belts properly tensioned and running correctly? | <input type="checkbox"/> 8. Are all hydraulic lines free from leaks and tight? |
| <input type="checkbox"/> 3. Can reel tines be adjusted properly? | <input type="checkbox"/> 9. Are all guards, shields etc. installed? |
| <input type="checkbox"/> 4. Are knives centered in cutterbar? | <input type="checkbox"/> 10. Paint and decals smooth and neat? |
| <input type="checkbox"/> 5. Is reel lift device working correctly? | <input type="checkbox"/> 11. Have cutting platform operation and safety rules been explained to the operator? |
| <input type="checkbox"/> 6. Is reel fore-and-aft adjusting device working properly? | |

Signature Dealer/Service Technician:

Date:

Identification View

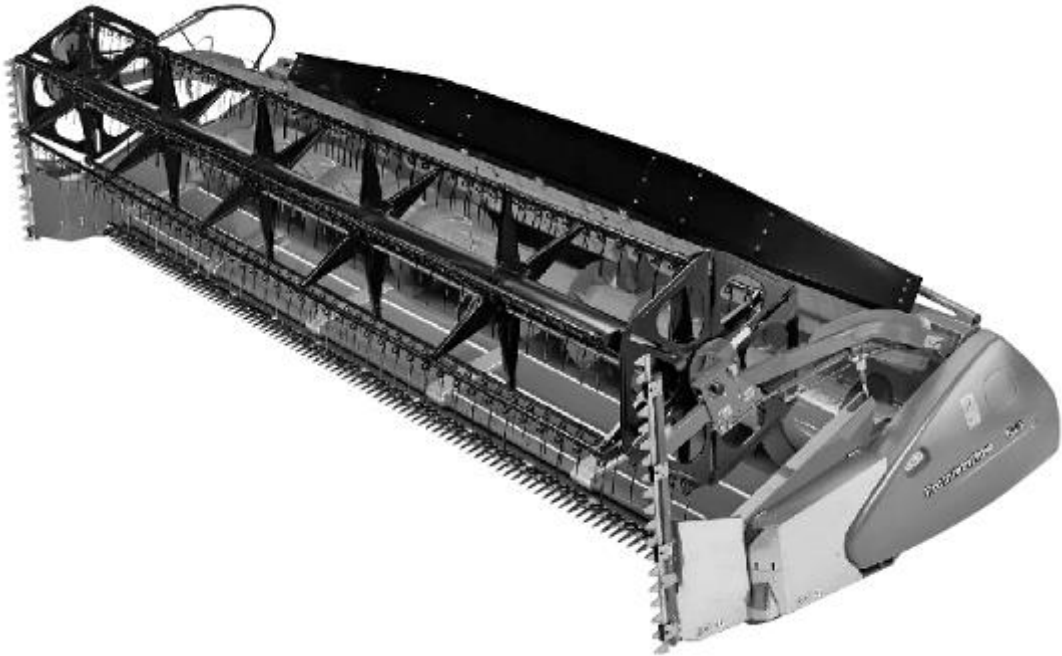

600PF Series Cutting Platform

Safety

Recognize Safety Information

This is a safety-alert symbol. When you see this symbol on your machine or in this manual, be alert to the potential for personal injury.

Follow recommended precautions and safe operating practices.



Follow Safety Instructions

Carefully read all safety messages in this manual and on your machine safety signs. Keep safety signs in good condition. Replace missing or damaged safety signs. Be sure new equipment components and repair parts include the current safety signs. Replacement safety signs are available from your John Deere dealer.

Learn how to operate the machine and how to use controls properly. Do not let anyone operate without instruction.

Keep your machine in proper working condition. Unauthorized modifications to the machine may impair the function and/or safety and affect machine life.

If you do not understand any part of this manual and need assistance, contact your John Deere dealer.

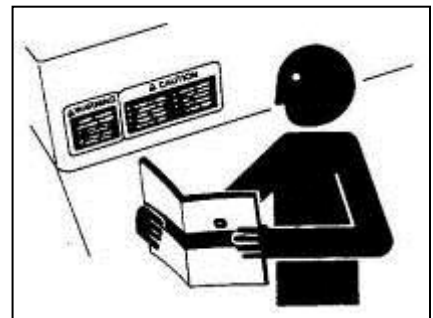

Observe Road Traffic Regulations

Always observe local road traffic regulations when using public roads.

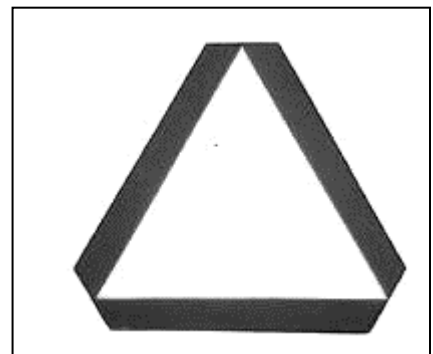

Safety

Use Safety Lights and Devices

Slow moving tractors, self-propelled equipment and towed implements or attachments can create a hazard when driving on public roads. They are difficult to see, especially at night. Avoid personal injury or death resulting from collision with a vehicle.

If legally permitted, use flashing warning lights or rotary beacons whenever driving on public roads. To increase visibility, use the lights and devices provided with your machine. For some equipment, install additional flashing warning lights.

Keep safety items in good condition. Replace missing or damaged items. An implement safety lighting kit is available from your John Deere dealer.

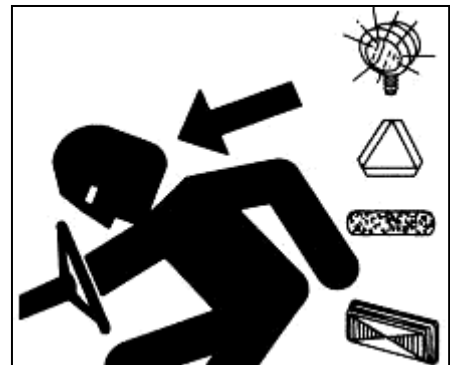

Prepare for Emergencies

Be prepared if a fire starts.

Keep a first aid kit and fire extinguisher handy.

Keep emergency numbers for doctors, ambulance service, hospital, and fire department near your telephone.

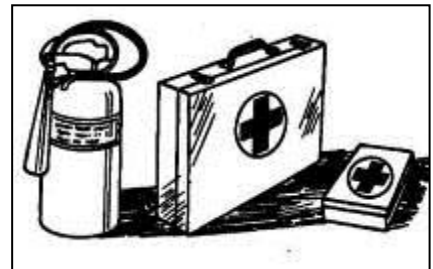

Wear Protective Clothing

Wear close fitting clothing and safety equipment appropriate to the job.

Prolonged exposure to loud noise can cause impairment or loss of hearing.

Wear a suitable hearing protective device such as earmuffs or earplugs to protect against objectionable or uncomfortable loud noises.

Operating equipment safely requires the full attention of the operator. Do not wear radio or music headphones while operating machine.

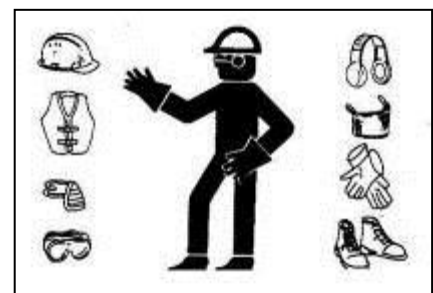

Safety

Store Attachments Safely

Stored attachments such as dual wheels, cage wheels, and loaders can fall and cause serious injury or death.

Securely store attachments and implements to prevent falling. Keep playing children and bystanders away from storage area.

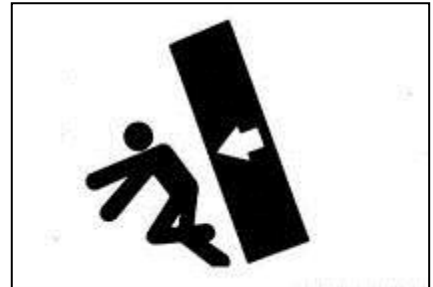

Guards and Shields

Keep guards and shields in place at all times. Ensure that they are serviceable and installed correctly.

Always disengage main clutch, shut off engine and remove key before removing any guards or shields.

Keep hands, feet and clothing away from moving parts.

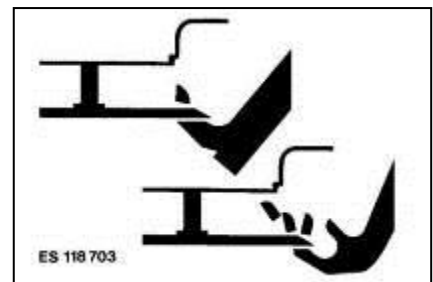

Stay Clear of Harvesting Units

Cutterbar, auger, reel and feed rolls cannot be completely shielded due to their function. Stay clear of these moving elements during operation. Always disengage main clutch, shut off engine and remove key before servicing or unclogging machine.



Keep Hands Away From Knives

Never attempt to clear obstructions in front of or on harvesting unit unless main clutch is disengaged, engine shut off and key removed.

Everyone must be clear of the machine before starting the engine.



Safety

Stay Clear of Rotating Drivelines

Entanglement in backshaft rotating driveline can cause serious injury or death.

Keep driveline shields in place at all times.

Wear close-fitting clothing. Stop the combine engine and be sure driveline is stopped before making adjustments, connections, or cleaning out header or its drive components.



Stay Clear of Cutterbar When Rotating Auger

The cutterbar knife and cross auger use a common belt drive. Whenever the auger is rotated by hand the cutterbar will move. Use extreme caution to keep hands, feet and clothing clear of the cutterbar and its knives when attempting to rotate cross auger for service, adjustment, inspection or unplugging.



Ballasting for Safe Ground Contact

Operating, steering and braking performance of combine can be considerably affected by heavy front end attachments which alter the center of gravity of the combine. To maintain the necessary ground contact, ballast the combine at the rear end as necessary. Observe the maximum permissible axle loads and total weights.

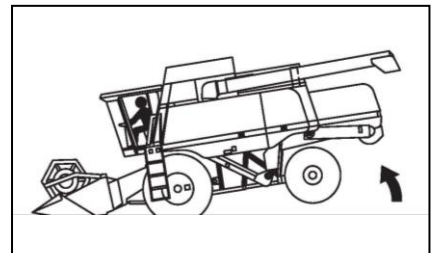

Safety

Practice Safe Maintenance

Understand service procedure before doing work. Keep area clean and dry.

Never lubricate, service, or adjust machine while it is moving. Keep hands, feet, and clothing from power-driven parts. Disengage all power and operate controls to relieve pressure. Lower equipment to the ground. Stop the engine. Remove the key. Allow machine to cool.

Securely support any machine elements that must be raised for service work.

Keep all parts in good condition and properly installed. Fix damage immediately. Replace worn or broken parts. Remove any build-up of grease, oil, or debris.

On self-propelled equipment, disconnect battery ground cable (-) before making adjustments on electrical systems or welding on machine.

On towed implements, disconnect wiring harnesses from tractor before servicing electrical system components or welding on machine.



Service Machines Safely

Tie long hair behind your head. Do not wear a necktie, scarf, loose clothing, or necklace when you work near machine tools or moving parts. If these items were to get caught, severe injury could result.

Remove rings and other jewellery to prevent electrical shorts and entanglement in moving parts.

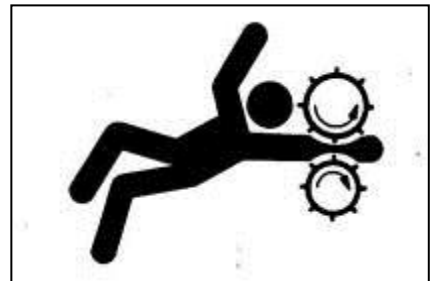

Safety

Support Machine Properly

Always lower the attachment or implement to the ground before you work on the machine. If the work requires that the machine or attachment be lifted, provide secure support for them. If left in a raised position, hydraulically supported devices can settle or leak down.

Do not support the machine on cinder blocks, hollow tiles, or props that may crumble under continuous load. Do not work under a machine that is supported solely by a jack. Follow recommended procedures in this manual.

When implements or attachments are used with a machine, always follow safety precautions listed in the implement or attachment operator's manual.

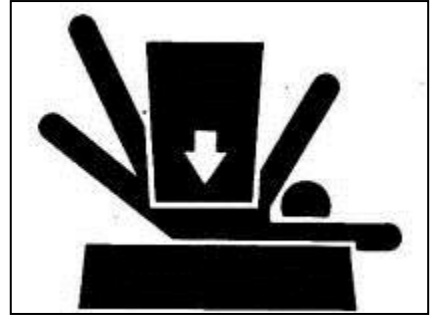

Protect Against Noise

Prolonged exposure to loud noise can cause impairment or loss of hearing.

Wear a suitable hearing protective device such as earmuffs or earplugs to protect against objectionable or uncomfortable loud noises.

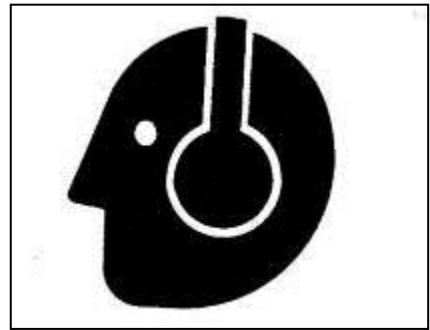

Avoid Heating near Pressurized Fluid Lines

Flammable spray can be generated by heating near pressurized fluid lines, resulting in severe burns to yourself and bystanders. Do not heat by welding, soldering, or using a torch near pressurized fluid lines or other flammable materials. Pressurized lines can accidentally burst when heat goes beyond the immediate flame area.



Safety

Avoid High-Pressure Fluids

Escaping fluid under pressure can penetrate the skin causing serious injury.

Avoid the hazard by relieving pressure before disconnecting hydraulic or other lines. Tighten all connections before applying pressure.

Search for leaks with a piece of cardboard. Protect hands and body from high pressure fluids.

If an accident occurs, see a doctor immediately. Any fluid injected into the skin must be surgically removed within a few hours or gangrene may result. Doctors unfamiliar with this type of injury should reference a knowledgeable medical source. Such information is available from Deere & Company Medical Department in Moline, Illinois, U.S.A.

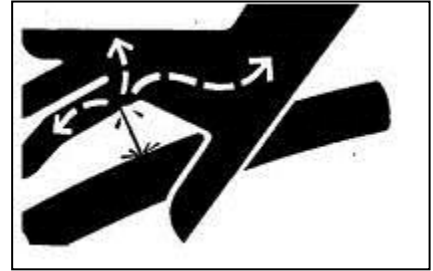

Dispose of Waste Properly

Improperly disposing of waste can threaten the environment and ecology. Potentially harmful waste used with John Deere equipment includes such items as oil, fuel, coolant, brake fluid, filters, and batteries.

Use leakproof containers when draining fluids. Do not use food or beverage containers that may mislead someone into drinking from them.

Do not pour waste onto the ground, down a drain, or into any water source.

Air conditioning refrigerants escaping into the air can damage the Earth's atmosphere. Government regulations may require a certified air conditioning service center to recover and recycle used air conditioning refrigerants.

Inquire on the proper way to recycle or dispose of waste from your local environmental or recycling center, or from your John Deere dealer.

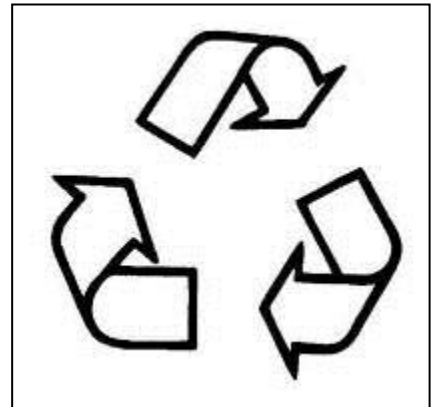

Safety Decals

Pictorial Safety Signs

At several important places of this machine safety signs are affixed intended to signify potential danger. The hazard is identified by a pictorial in a warning triangle. An adjacent pictorial provides information how to avoid personal injury. These safety signs, their placement on the machine and a brief explanatory text are shown below.



Cutting Platform

DANGER- Stay clear of header. Disengage header drive, shut off engine and remove key before servicing or unclogging header.

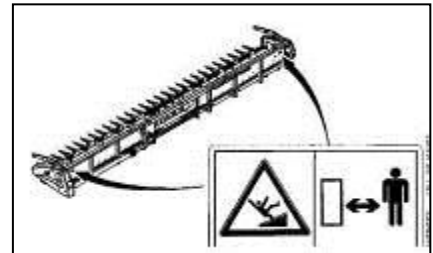

Cutting Platform Drive Shaft

Stay clear of rotating drive shaft to avoid personal injury!

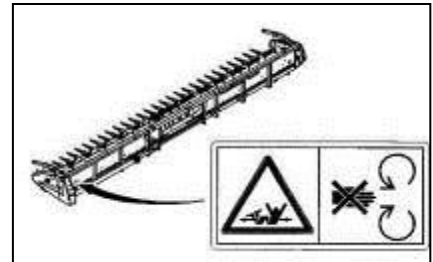

Shields on Cutting Platform Drives

Do not open or remove safety shields while the engine is running.

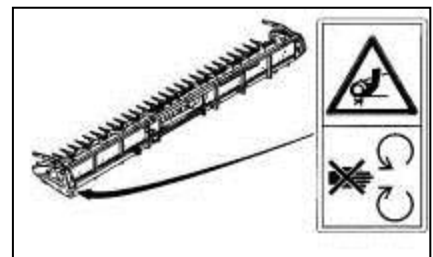

Reel Lifting Cylinder

Secure lifting cylinder with locking device before entering hazardous area.

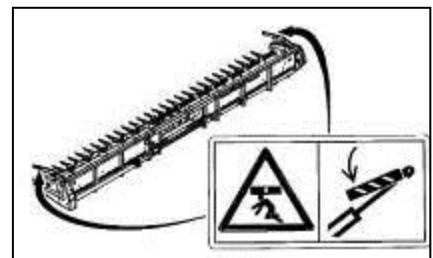

Adjusting Cutting Platform

Checking Auger Stripper Location

Caution:

Whenever the auger is rotated by hand the cutterbar will move. Use extreme caution to keep hands, feet and clothing clear of the cutterbar and its knives when attempting to rotate cross auger for service, adjustment, inspection or unplugging

Note:

Auger and strippers of the cutting platform must be adjusted to the combine to ensure optimum feeding of material from the cutting platform to the feeder house. Adjusting the cutting platform to the combine will result in even feeding of material across the entire width of the feeder house. This will result in even distribution of the material within the separator and high threshing performance.

Adjusting cutting platform for W650, W660, T660, T670 Auger

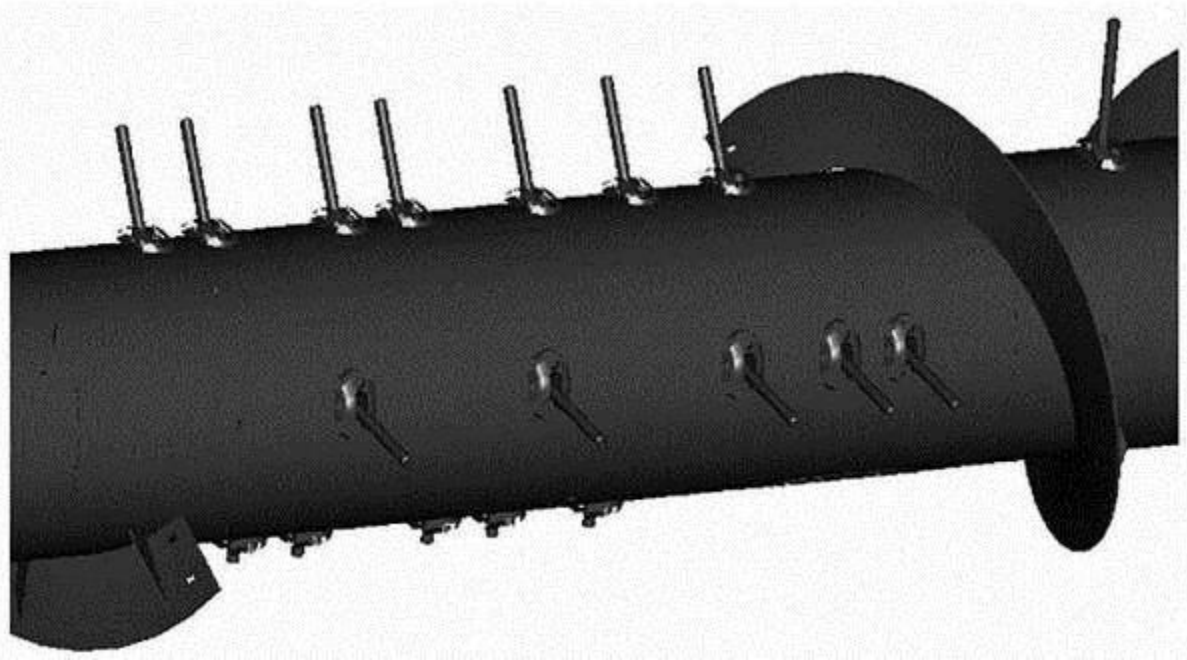

If the cutting platform is attached to a W650, W660, T660 or T670 combine, the maximum possible number of auger fingers (22) must be installed. The flight extensions must be completely removed.

Adjusting Cutting Platform

Stripper

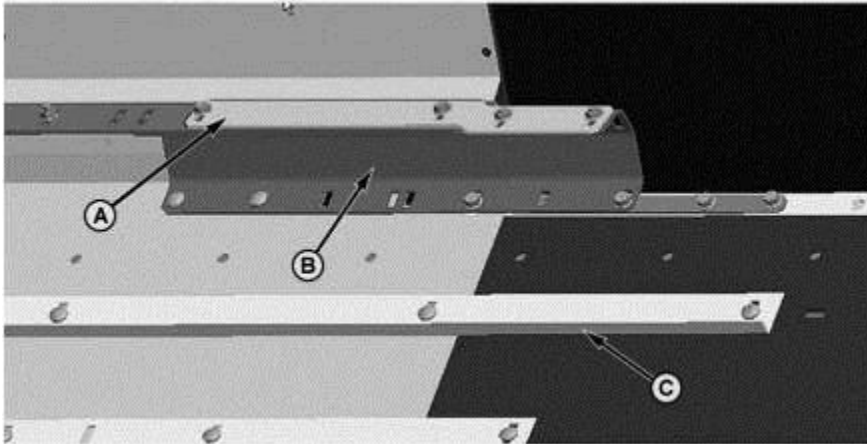

A- Stripper H210729

B- Stripper Bracket

C- Floor stripper

Align the long end of stripper (A) towards the outside of the cutting platform and place the stripper onto bracket (B). Align the shoulder of the stripper with the vertical end edge of the cutting platform rear wall and fix with screws.

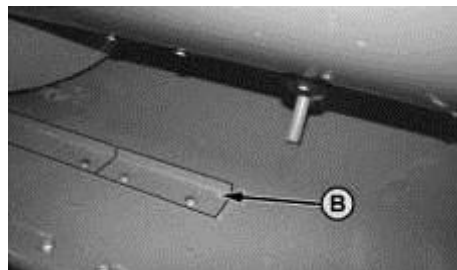
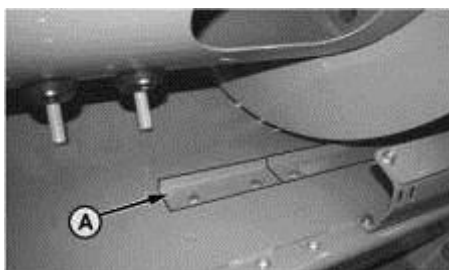
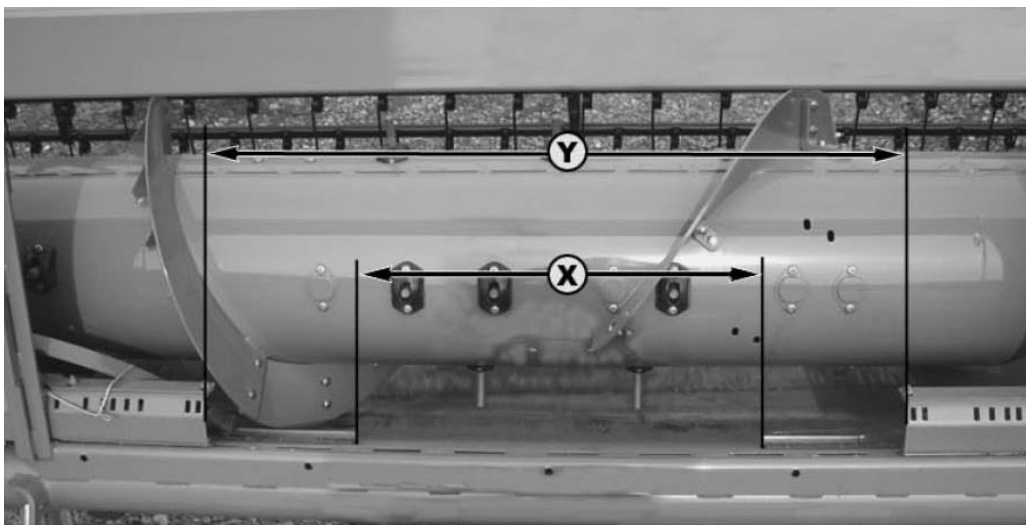

A- Right floor stripper extension

B- Left floor stripper extension

X- Clearance of floor strippers, 1080mm (42.50 in.)

Y- Clearance of rear strippers, 1450mm (57.00 in.)

Remove right and left extensions (A and B) of the floor stripper.

Adjusting Cutting Platform

Adjusting cutting platform for W650, W660, T660, T670 HillMaster Auger

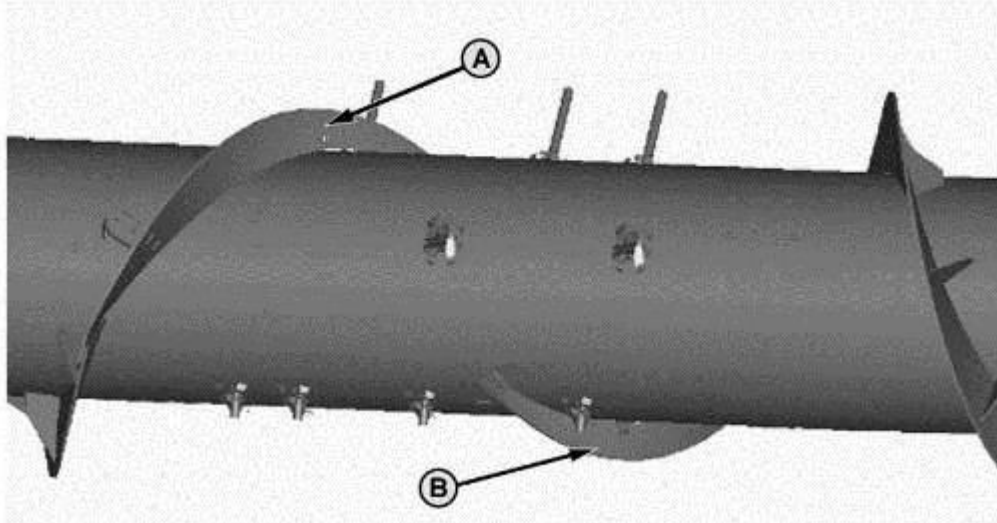

A- Left flight extension, Z106382

B- Right flight extension, Z106383

If the cutting platform is attached to a W650, W660, T660, T670 HillMaster combine, 18 auger fingers must be installed. At four locations caps are installed. The flight extensions are installed on the right and left.

The locations marked by arrows are not provided with intake fingers. The openings are sealed with caps.

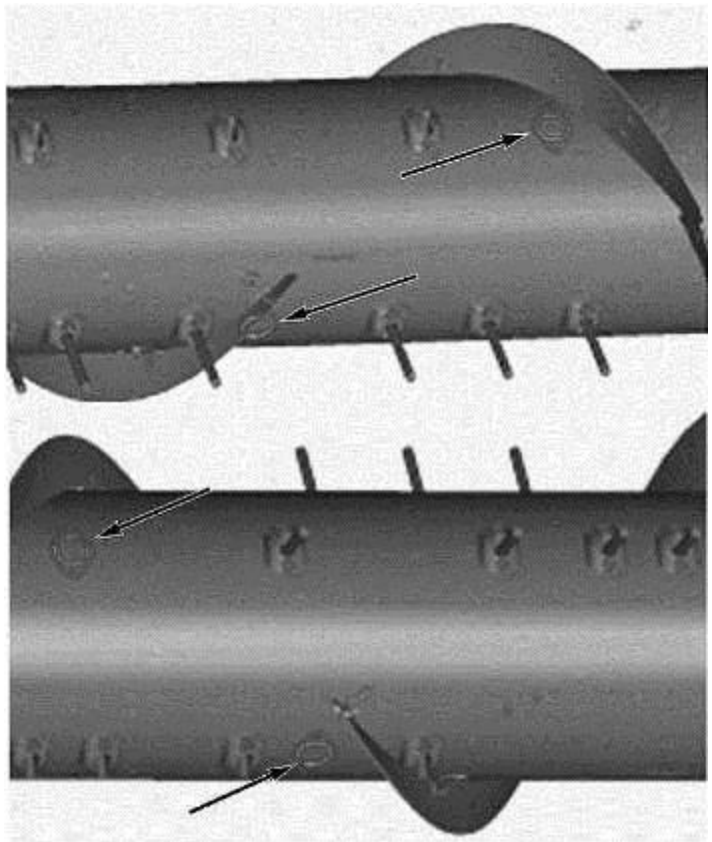

Adjusting Cutting Platform

Stripper

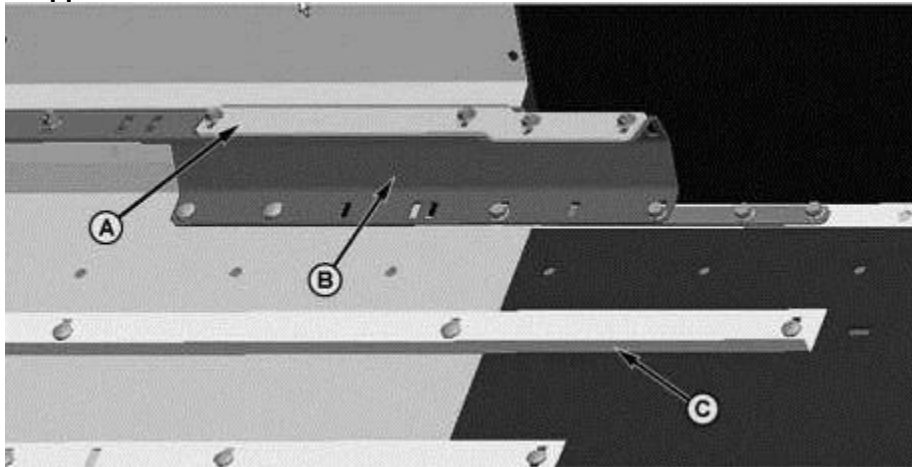

A- Stripper H210729

B- Stripper bracket

C- Floor stripper

Align the long end of stripper (A) towards the outside of the cutting platform and place the stripper onto bracket (B). Align the shoulder of the stripper with the vertical end edge of the cutting platform rear wall and fix with screws.

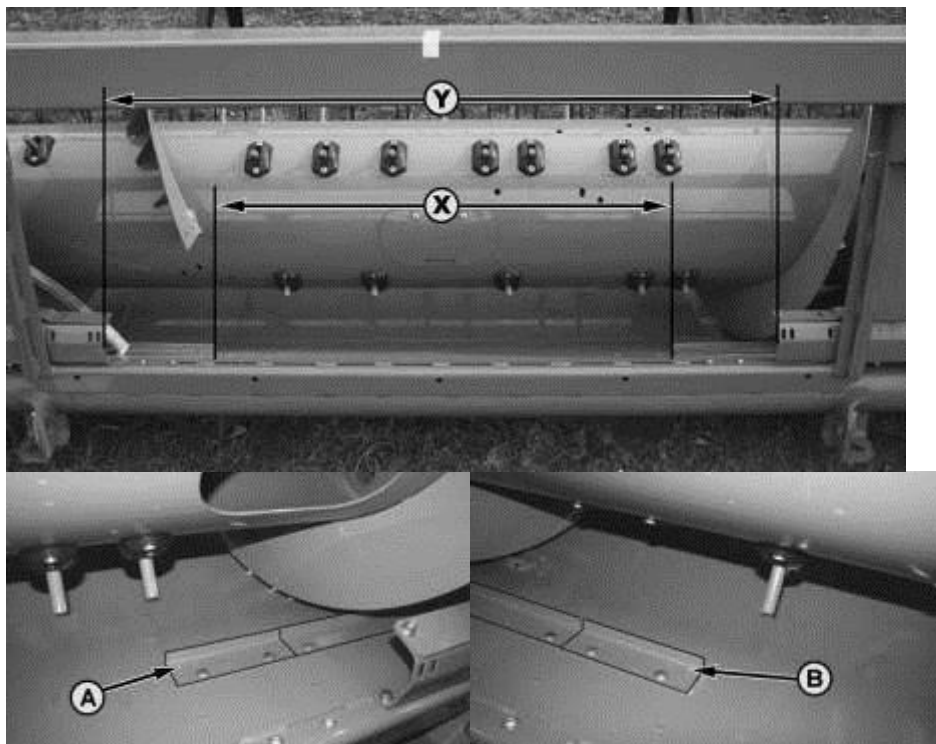

Remove right and left extensions (A and B) of the floor stripper.

A- Right Floor Stripper Extension

B- Left Floor Stripper Extension

X- Clearance of Floor Strippers, 1080 mm (42.50in.)

Y- Clearance of Rear Strippers, 1450 mm (57.00in.)

Adjusting Cutting Platform

Adjusting cutting platform for W540, W550, T550, T560 Auger

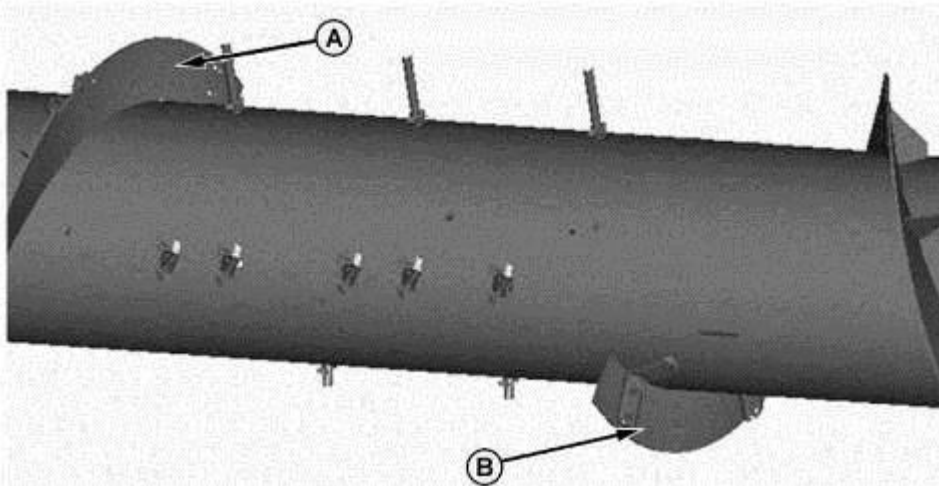

A- Left Flight Extension, Z106380
B- Right Flight Extension Z106381

If the cutting platform is attached to a W540, W550, T55 or T560 combine, 15 auger fingers must be installed. At seven locations a cover plate is installed. The flight extensions are installed on the right and left.

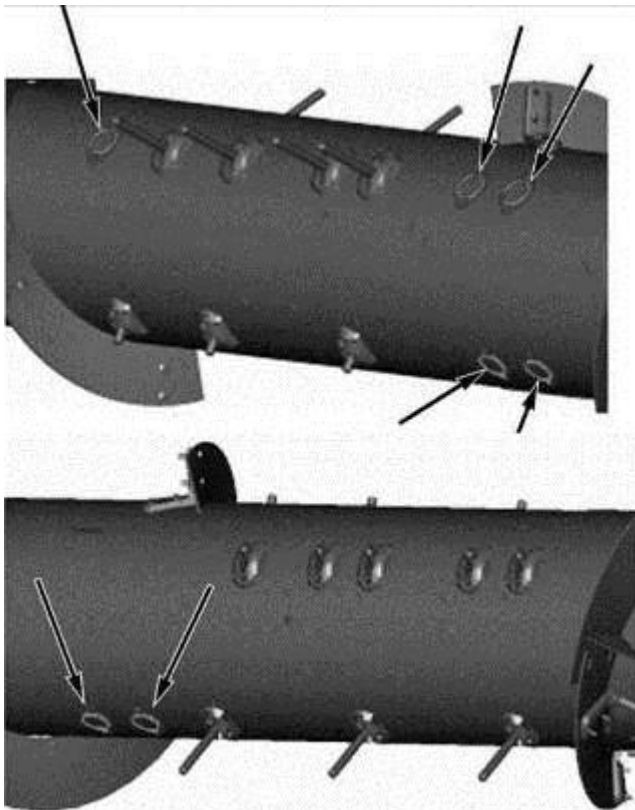

The locations marked by arrows are not provided with intake fingers. The openings are sealed with caps.

Adjusting Cutting Platform

Stripper

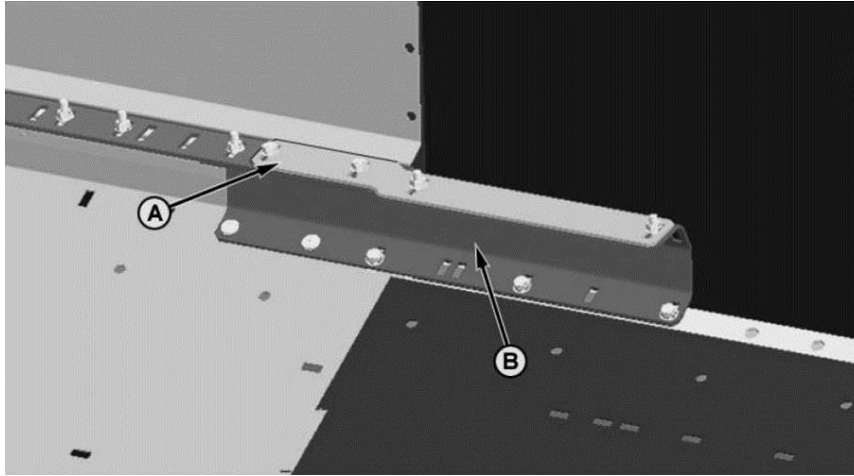

A- stripper H210729

B- Stripper bracket

Align the long end of stripper (A) towards the inside of the cutting platform and place the stripper onto bracket (B). Align the shoulder of the stripper with the vertical end edge of the cutting platform rear wall and fix with screws.

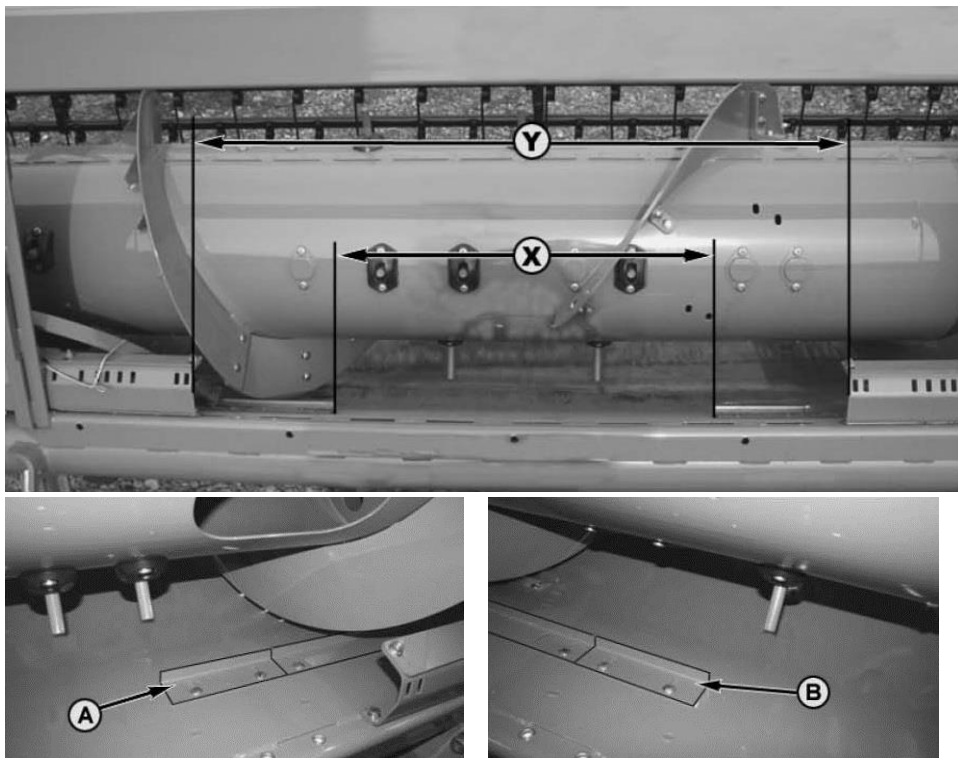

Install right and left extensions (A and B) on the floor stripper using screws.

A- Right Floor Stripper Extension

B- Left Floor Stripper Extension

X- Clearance of Floor Strippers, 740 mm (29.00in.)

Y- Clearance of Rear Strippers, 1150 mm (45.30in.)

Adjusting Cutting Platform

Adjusting cutting platform for W540, W550, T550, T560 HillMaster Auger

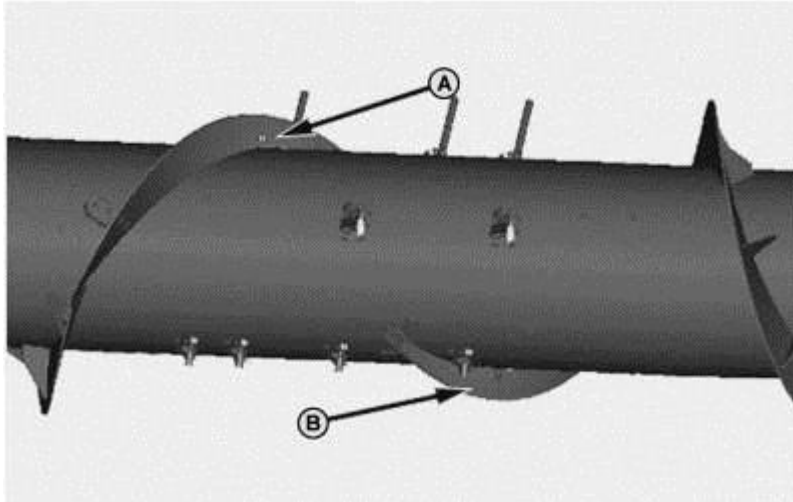

A- Left Flight Extension, Z106382

B- Right Flight Extension, Z106383

If the cutting platform is attached to a W540, W550, T550 or T560 HillMaster combine, eleven auger fingers must be installed. At eleven locations a cover plate is installed. The flight extensions are installed on the right and left.

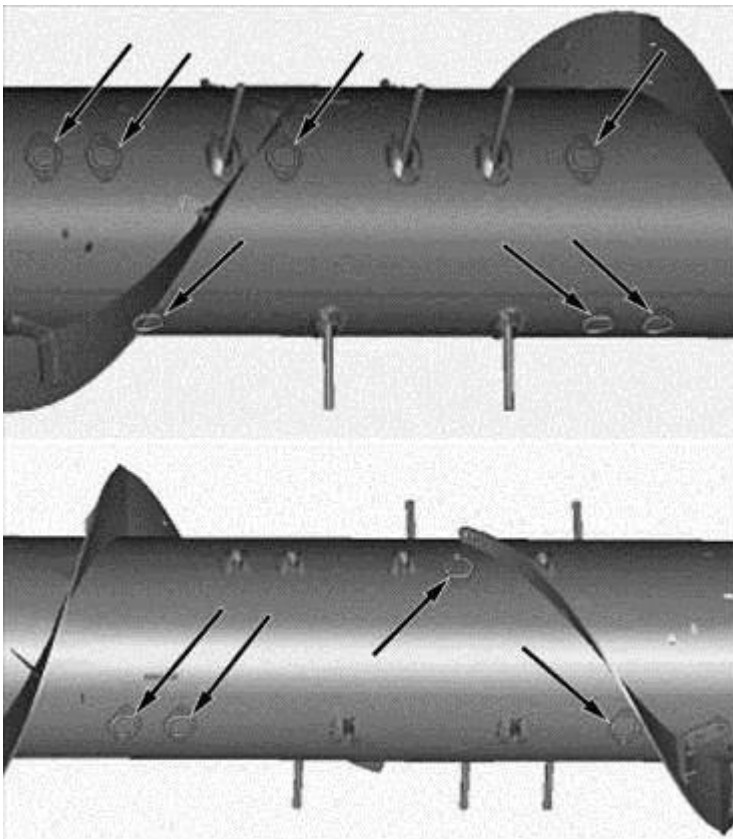

The locations marked by arrows are not provided with intake fingers. The openings are sealed with caps.

Adjusting Cutting Platform

Stripper

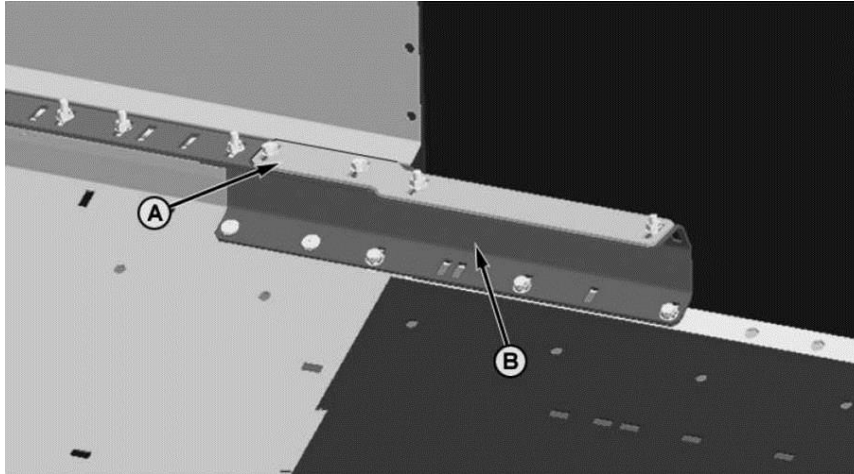

A- stripper H210729

B- Stripper bracket

Align the long end of stripper (A) towards the inside of the cutting platform and place the stripper onto bracket (B). Align the shoulder of the stripper with the vertical end edge of the cutting platform rear wall and fix with screws.

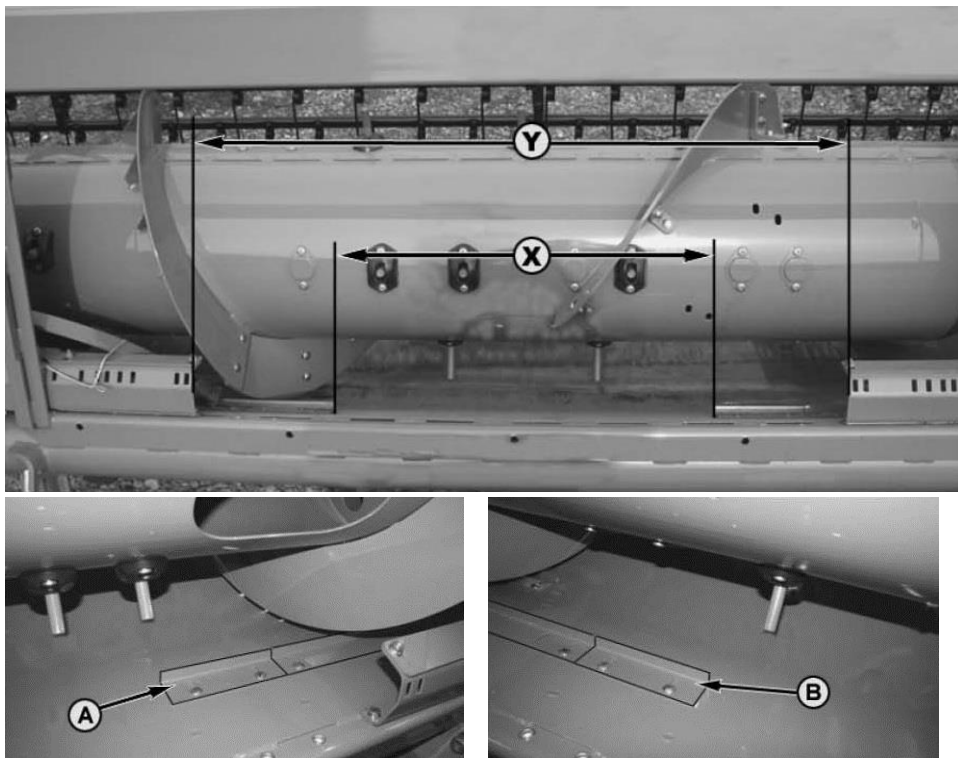

Install right and left extensions (A and B) on the floor stripper using screws.

A- Right Floor Stripper Extension

B- Left Floor Stripper Extension

X- Clearance of Floor Strippers, 740 mm (29.00in.)

Y- Clearance of Rear Strippers, 1150 mm (45.30in.)

Adjusting Cutting Platform

Adjusting cutting platform for S660, S670 Auger

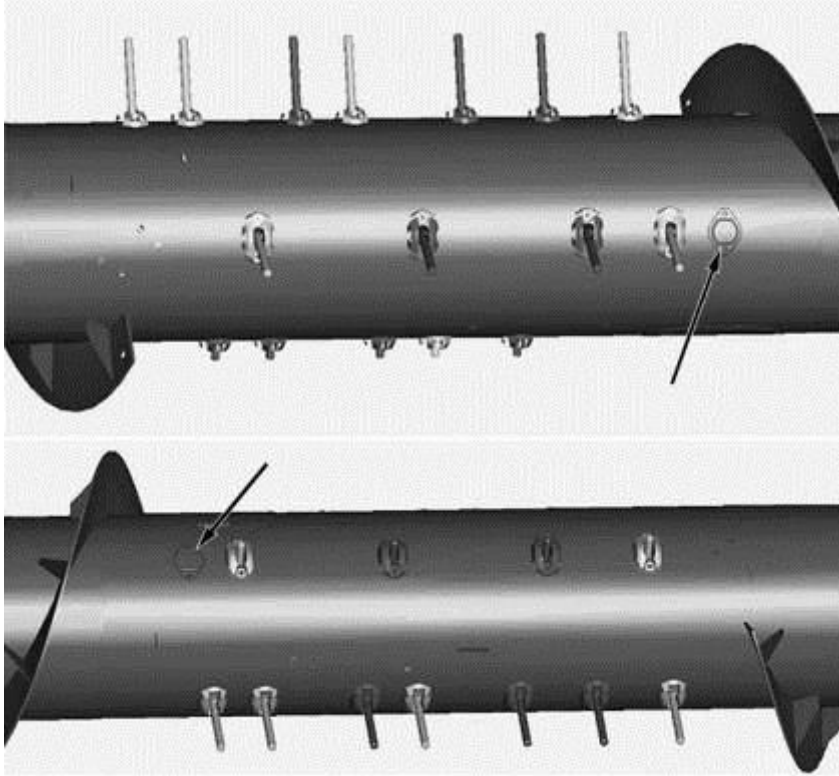

If the cutting platform is attached to a S660, S670 combine, 20 auger fingers must be installed. At two locations marked by arrows caps are installed. The flight extensions must be completely removed.

Adjusting Cutting Platform

Adjusting cutting platform for S680, S690 only for 30/35FT Auger

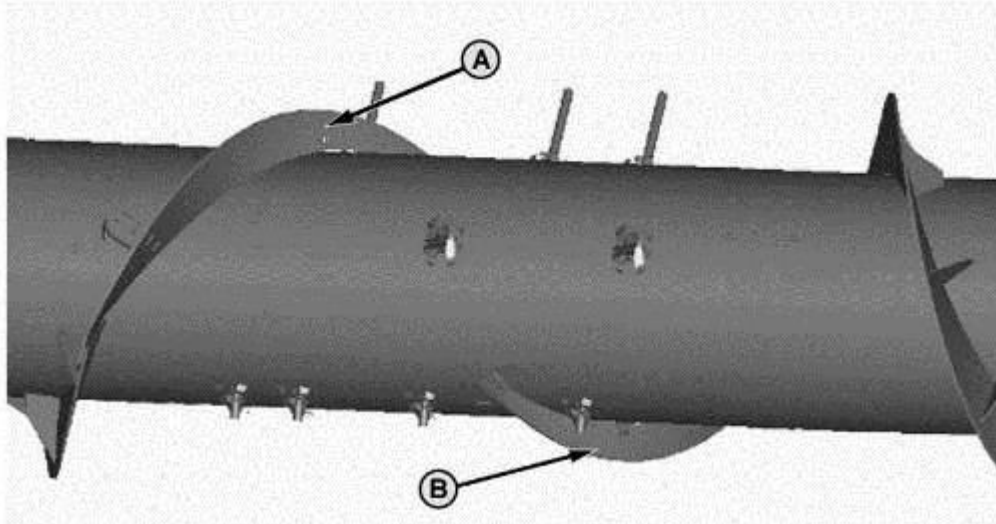

A- Left flight extension, Z106382

B- Right flight extension, Z106383

If the cutting platform is attached to a S680, S690 combine, 18 auger fingers must be installed. At four locations caps are installed. The flight extensions are installed on the right and left.

The locations marked by arrows are not provided with intake fingers. The openings are sealed with caps.

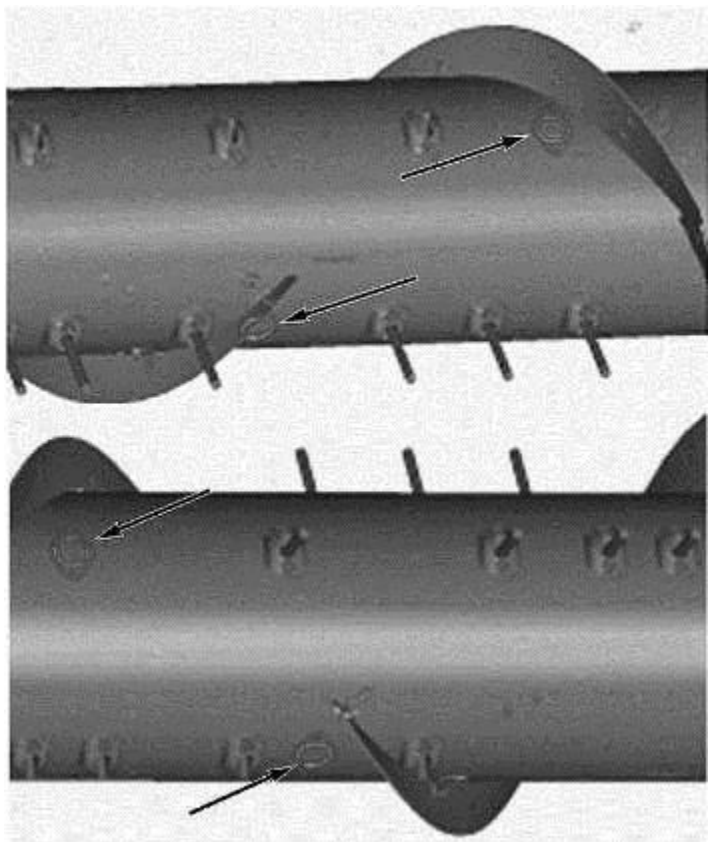

Adjusting Cutting Platform

Stripper

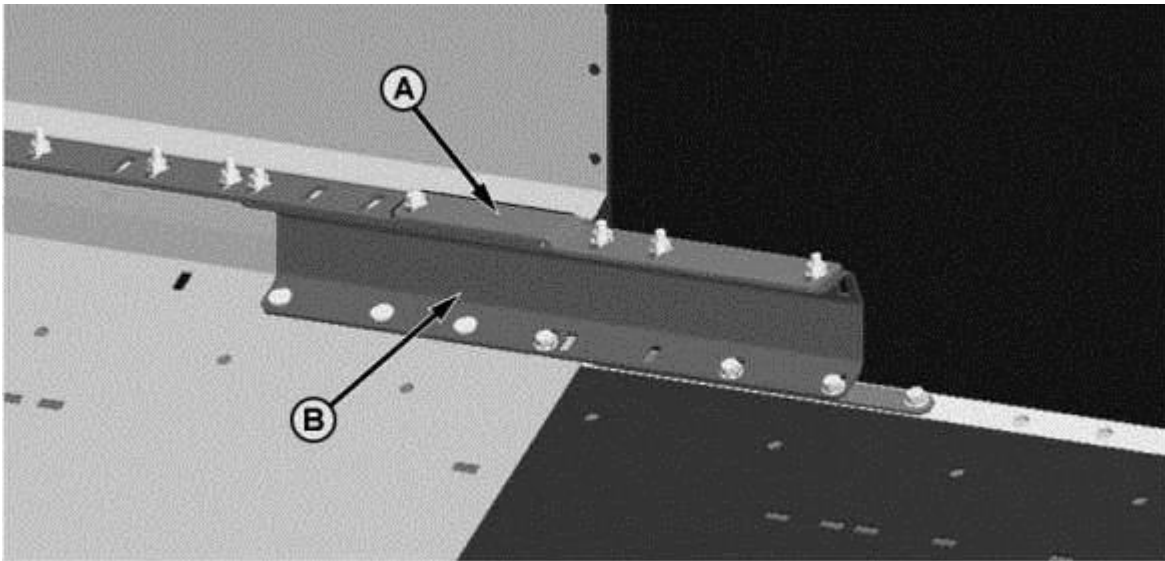

- A- Stripper
- B- Stripper Bracket

Align the long end of stripper (A) towards the inside of the cutting platform and place the stripper onto bracket (B). Align the shoulder of the stripper with the vertical end edge of the cutting platform rear wall and fix with screws.

The Stripper has to fix for permanent supporting cutting platforms on S-combine and change for provided Stripper angle (C) and Stripper (D). In the 35ft cutting platforms are the Stripper serially adjusted for the S-combines.

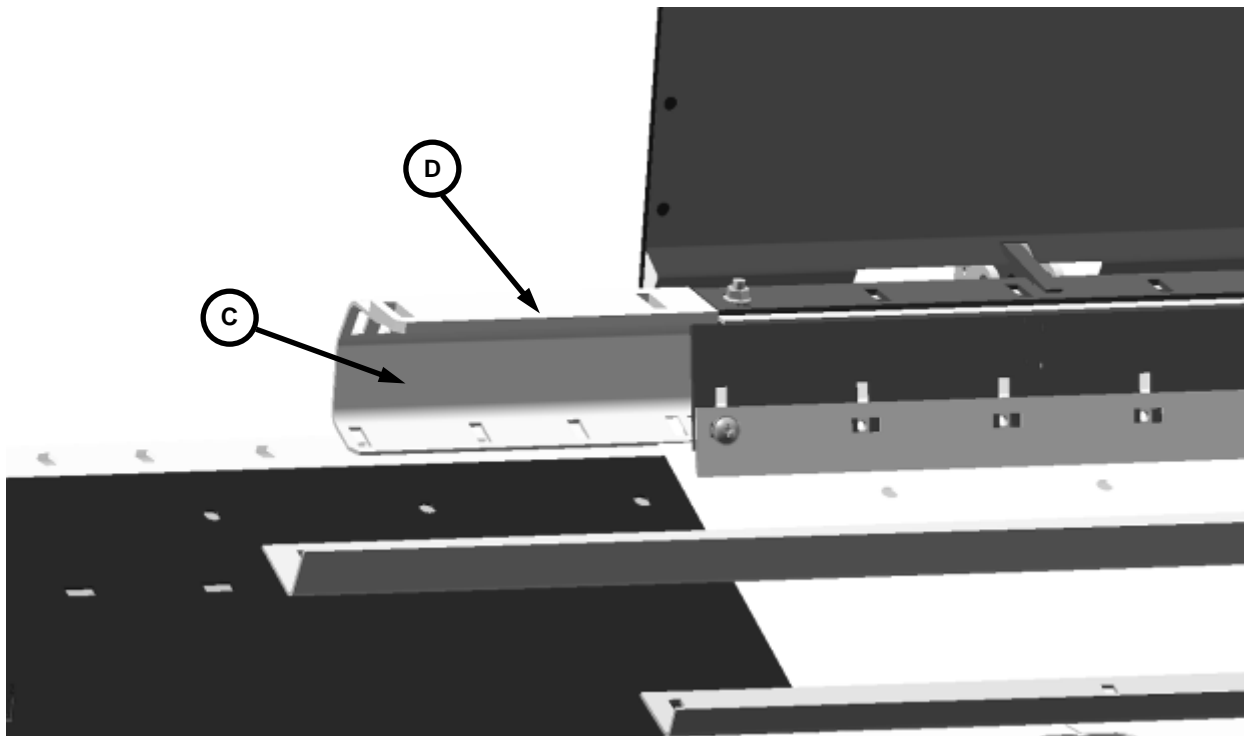

Adjusting Cutting Platform

Floor Stripper Extension

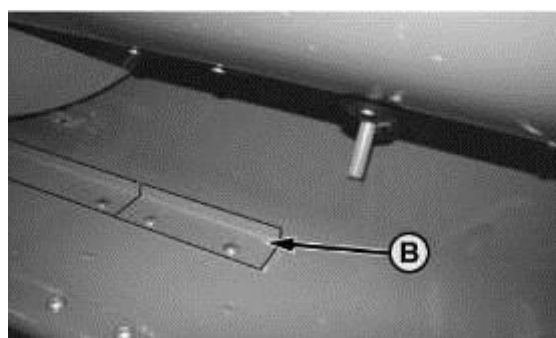
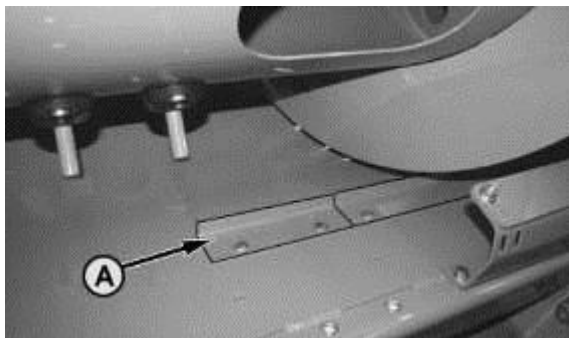
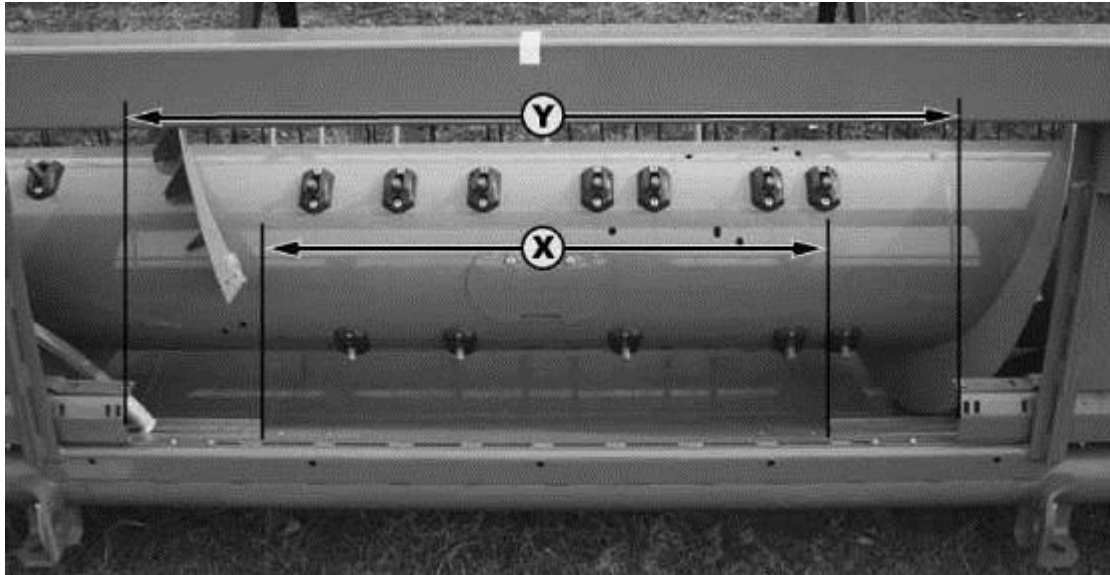

A- Right Floor Stripper Extension

B- Left Floor Stripper Extension

X- Clearance of Floor Strippers, 1080 mm (42.50in.)

Y- Clearance of Rear Strippers, 1285 mm (50.60in.)

Install right and left extensions (A and B) on the floor stripper using screws.

Attaching and Detaching

Adjust Lock

Distance (X) from locking pin (B) to adjusting plate (A) must not exceed 5 mm (0.2 in.). For adjustment, loosen screws (C) and slide plate (A) vertically. Retighten screws (C).

Important: When locking the cutting platform, make sure that locking pin (B) is able to extend completely after vertical adjustment of plate (A).

A- Adjusting Plate

B- Locking Pin

C- Screw

X- Dimension, 5 mm (0.2 in.) maximum

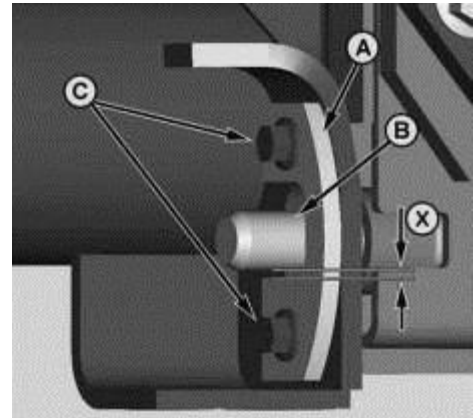

Attach Cutting Platform to Combine

Drive combine slowly forward until feeder house is centered in platform opening. Raise the feeder house, making sure two hooks (A) on feeder house catch front side of top beam of platform.

A- Hook

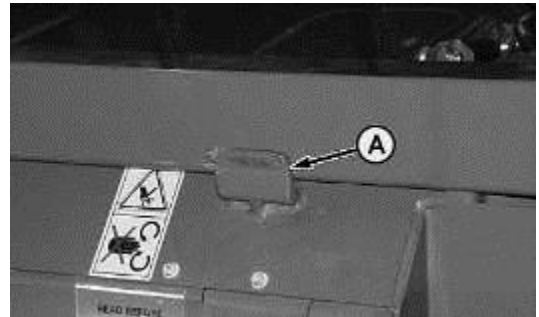

Connect u.j. shaft to feeder house countershaft, making sure the quick-attach collar (B) locks fully.

B- Quick-Attach Collar

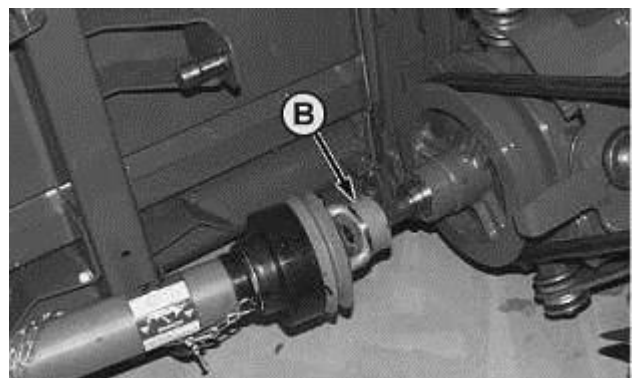

Attaching and Detaching

At the feeder house, connect multicoupler (D) to support for multicoupler (E) and secure it with strap (F).

Note: Turning strap (F) over at the same time locks the platform to the feeder house.

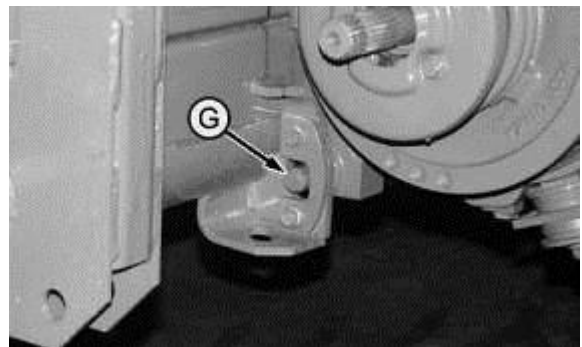
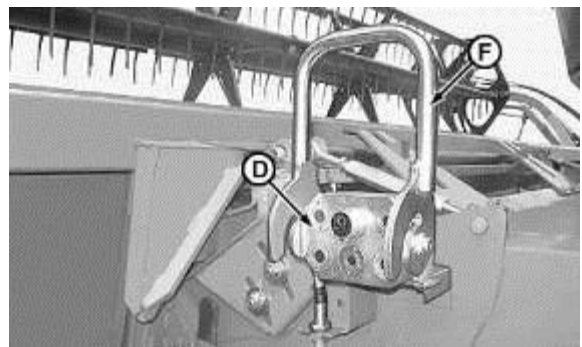
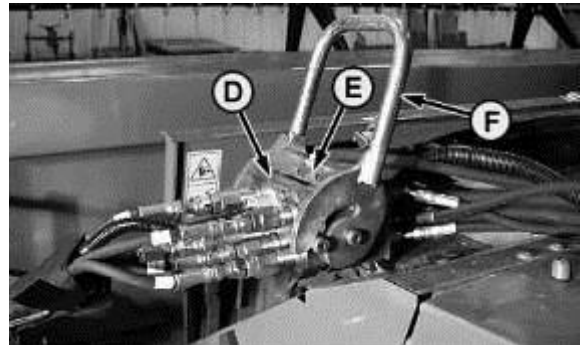

- D- Multi-Coupler
- E- Support for Multi-Coupler
- F- Strap
- G- Platform Lock

Attaching and Detaching

Detach Cutting Platform

Note: Opening strap (F) at the same time unlocks the platform from the feeder house.

Open strap (F) and detach multicoupler (D) from its support (E).

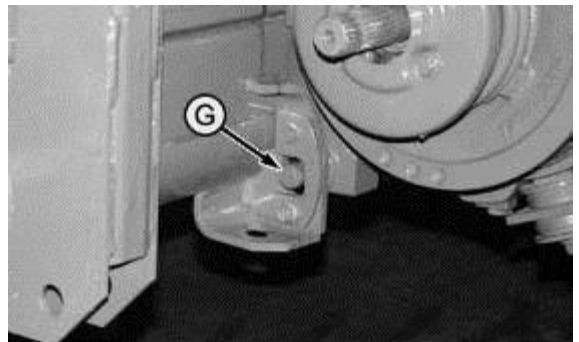
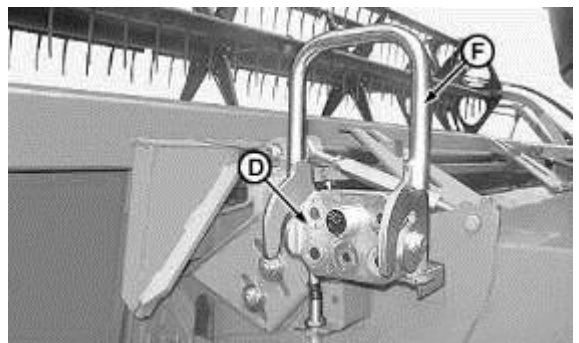
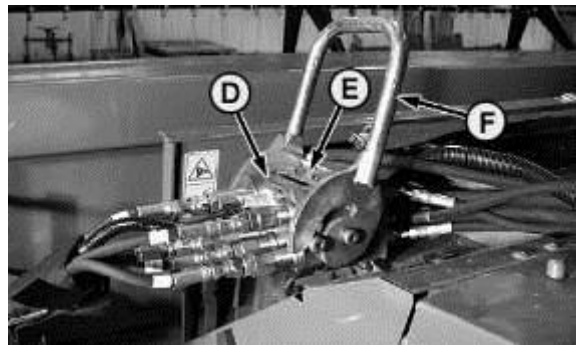

- D- Multi-Coupler
- E- Support for Multi-Coupler
- F- Strap
- G- Platform Lock

Attaching and Detaching

Put multicoupler (D) in its storage position, and secure with strap (C).

C- Strap
D- Multi-Coupler

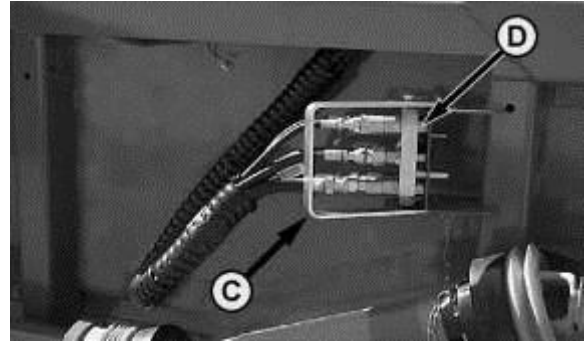

Slide collar (B) back and take off the u.j. shaft. Put the u.j. shaft on the pin (H) that holds it in its rest position.

B- Quick-Attach Collar
H- Pin for Holding the U.J.Shaft in its Rest Position

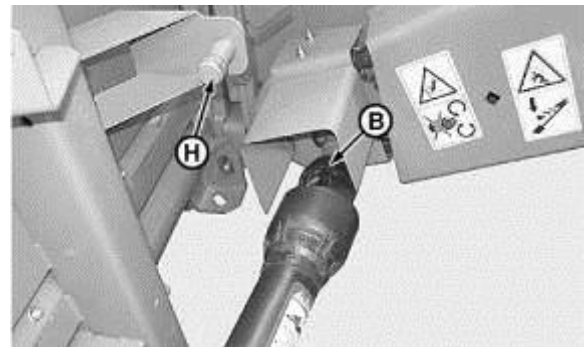
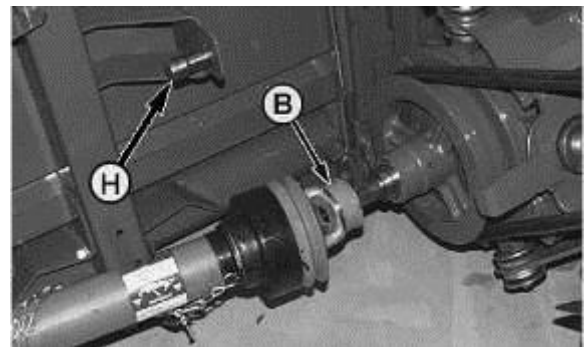

Transporting

Transporting the Cutting Platform

Because of its excessive width, the cutting platform must be placed on a suitable trailer before it is moved by road.

The short John Deere crop dividers have to be removed for transporting and must be placed either within the platform or on the platform trailer.

For further road transport instructions, see the combine Operator's Manual.

The Road Traffic Licensing Regulations must be complied with.



Operating the Platform

Cutting Platform Operation

To operate the cutting platform properly, pay attention to the following:

- Ground speed
- Cutting height
- Reel setting
- Auger setting

Cutting Height

To avoid grain losses, make sure that hanging grain heads are not damaged by the knives. Use lifting guards when harvesting down and tangled crops.

Cutting Platform Controls

For details of the cutting platform functions listed opposite, see relevant combine operator's manual.

- Raising and lowering cutting platform
- Cutting platform height resume control
- Reel fore-and-aft adjustment
- Reel speed adjustment
- Raising and lowering reel
- Reel height resume control
- Reel fore-and-aft resume control

Reel speed

The reel speed depends on several factors:

- High or low crop
- Stand density
- Standing crop or down crop

Basically, a too high reel speed entails grain losses.

Basic Positions for Different Crops

	Position auger auger fore/aft	Position reel	Position rear stripper	for 635P Only (and other headers with double belt speed)
Wheat	Lowest position	Slightly in intervention Reel-cart in position „grain“	3mm distance to auger	auger: see first column Belt drive speed: 60 teeth sprocket
Barley	Lowest position	Slightly in intervention Reel-cart in position „grain“	3mm distance to auger	auger: see first column Belt drive speed: 60 teeth sprocket
Rye	Lowest position	Slightly in intervention Reel-cart in position „grain“	3mm distance to auger	auger: see first column Belt drive speed: 60 teeth sprocket
Sunflowers	Lowest position	Install Sunflower-kit for reel Reel slightly in intervention	3mm distance to auger	auger: see first column Belt drive speed: 20 teeth sprocket, 38 teeth at shaft
Oil Seed Rape down	Eventually lowest position	Reel Reel-cart in position “Oil Seed Rape“	3mm distance to auger	auger: see first column Belt drive speed: 20 teeth sprocket
Oil Seed Rape high	Highest position auger fore/aft should be in its fully extended position !!! Before lowering the auger, the auger should be set in the rear position	Reel slightly in intervention Reel-cart in position “Oil Seed Rape“	3 mm distance to auger quick adjustment with Oil Seed Rape strippers (If necessary)	auger: see first column Belt drive speed: 20 teeth sprocket
Rice	Lowest Position	Install rice-kit for reel Standing Rice reel slightly in intervention Rice that is down reel in front of cutting system	3mm distance to auger (eventually closer)	
All Crops in Damp Ground Conditions	Lowest Position	Reel in retracted position More extended if crops are greener	3 mm distance to auger (eventually a little more aggressive)	auger: possibly 20mm elevated Belt drive speed: 40 teeth sprocket
All Laid Crops	Lowest position	Reel stronger in position. Eventually in front of the cutting system and lifting guards	3 mm distance to auger (eventually a little more aggressive)	auger: possibly 20mm elevated Belt drive speed: 40 teeth sprocket

Decal Belt Speed

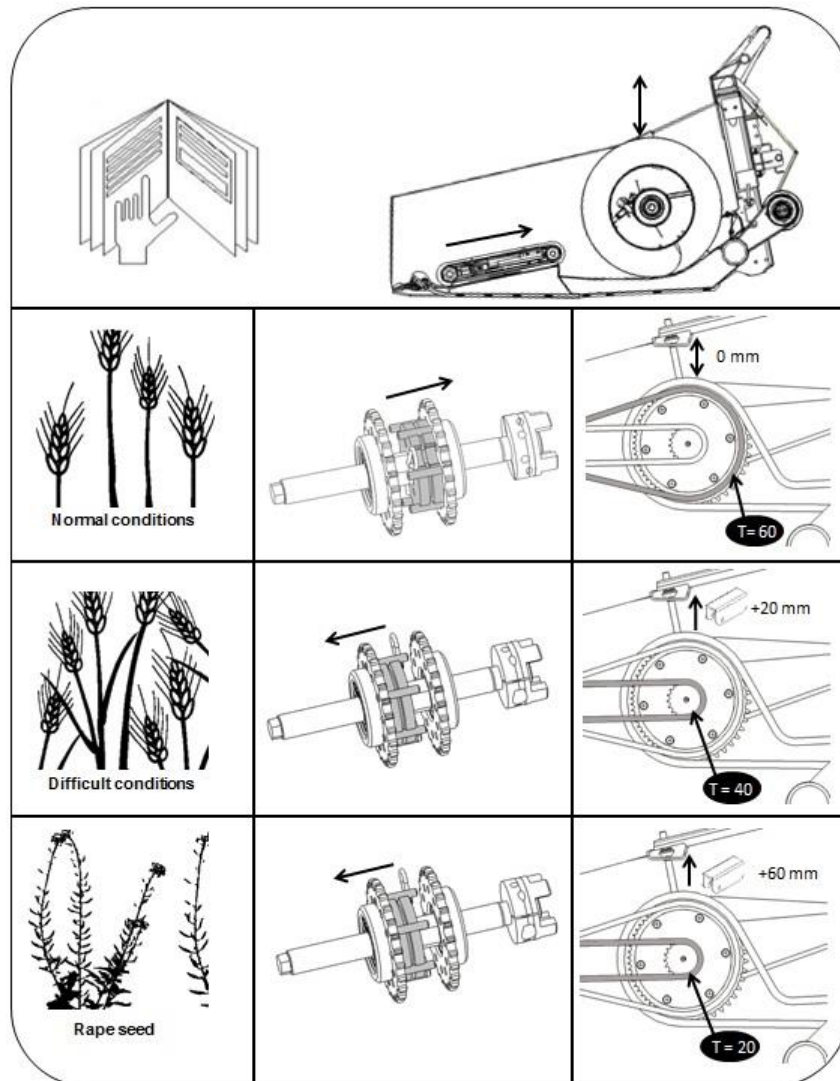

<p>Normal conditions</p> <p>Normale Erntebedingungen:</p>	<p>Middle to high yields, standing grain, mature straw</p>	<p>Switch shift collar on the inside sprocket of the drive shaft, drive chain is running on the inside sprocket with 60 teeth</p>
<p>Difficult conditions</p> <p>Schwierige Erntebedingungen:</p>	<p>Very high yields (especially in barley), lying grain, very green straw</p>	<p>Switch shift collar on the outside sprocket of the drive shaft, drive chain is running on the outside sprocket with 40 teeth (see on page 38 – fast change system chain sprocket). Lift the auger and lock with the retaining clip 20mm (see hydraulic auger height adjustment on page 41-44)</p>
<p>Rape seed</p> <p>Raps:</p>		<p>Switch shift collar on the outside sprocket of the drive shaft, drive chain is running on the outside sprocket with 20 teeth (see on page 38 – fast change system chain sprocket).</p> <p>Lift the auger and lock with the retaining clip 63mm (see hydraulic auger height adjustment on page 41-44)</p>

Attaching Side Knife for Oil Seed Rape

Remove crop divider and triangular side sheet extension



Remove side knife from transport position; the triangular side sheet extensions can be installed in the same position. For the cutting platforms 18 Ft (5,5m) and 20 Ft (6,1m) the Side knife holder is located at the platform trailer. For the cutting platforms 22 Ft (6,7m), 25 Ft (7,6m) and 30 Ft (9,15m), the side knife holder is located at the back side of the platform.



Hook the Oil Seed Rape Side Knives into the keyholes and connect the drive shaft with the horizontal cutting knife.



Attaching Side Knife for Oil Seed Rape

Important:
Pay attention to install a distance ring on both sides of the ball joint (see arrows) and tighten the screw.

(Left side of the platform: drive side)

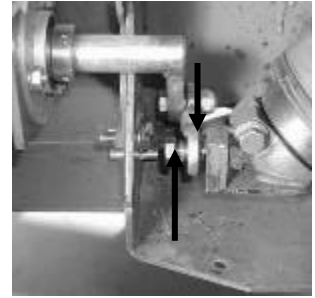

(Right side of the platform)



Double Speed Belt-Drive

To adjust the belt speed to the different harvesting Conditions the header has a double-stage chain drive, which can be changed by moving the selector.

Cereals: The selector is connected to the inner sprocket the outer chain is running without load. Oil Seed Rape/ Sunflowers: The selector is connected to the outer sprocket the inner chain is running without load.



Attention:

To reduce the wear, we propose to remove the chain which is not used to, in times when a change of speed is no longer required. (When header is only running in wheat)

The selector is connected to the inner sprocket. Position for the fast Belt speed

A



Double Speed Belt-Drive

Change the belt speed:

1. By turning the header bring the splint pin (A) in a position to pull it out easily.

A



2. Move the selector on the shaft until the pins of the Selector are no longer connected with the inner sprocket.



3. Turn the shaft with a wrench (Size 19) to align the pin of the selector to the holes in the sprocket, to connect these two parts.



4. Move the selector as close as possible to the outer sprocket and lock it with the splint pin.



Fast-change system chain sprocket belt speed

Open the chain lock of the outside belt drive chain and remove the chain. Loosen the flat counter nut and the nut on the sprocket of the adapter disc and remove the chain sprocket 20 teeth.

Put the chain sprocket 40 teeth on the center pins of the adapter disc and fix it with the nut. Lock the nut with the flat counter nut. Fit the new chain for the sprocket 40 teeth and check the chain tension.

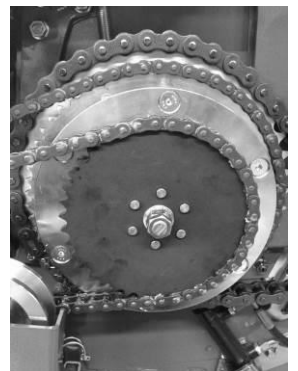
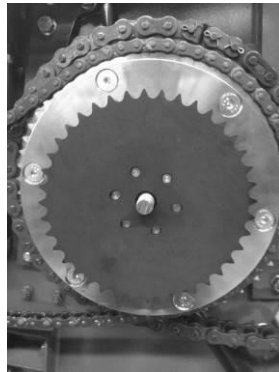
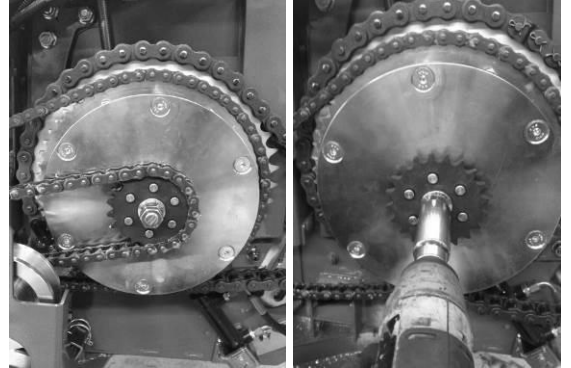

Positioning of Side Knife for Oil Seed Rape

The threaded rods of the side-knives have to be installed in that way that the section (B and C) are in the middle, to make sure that you have same over cut on both sides.

If necessary adjust the threaded rods (A).

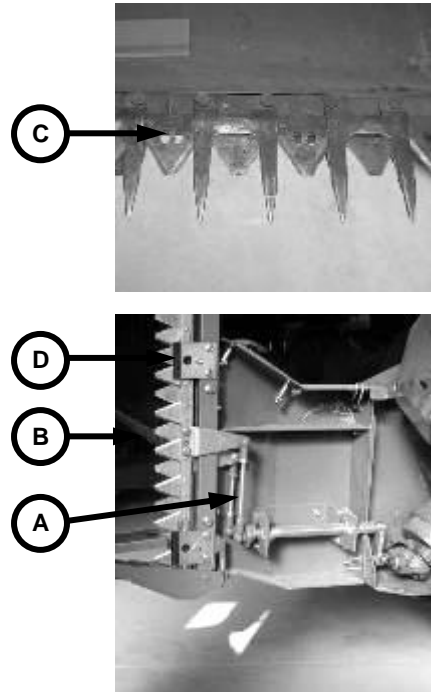

Adjusting Reel Support for Oil Seed Rape

This adjustable reel-cart extends the range of possible reel positions:

- In „Oil Seed Rape“- position the reel is closer to the auger and helps feeding the crop into the auger and into the feeder house.
- In “Grain” - position the reel is closer to the knife and helps bringing short material or laid down crops into the cutting platform.

Put reel arm in horizontal position, loosen security ring of bolt (A) and remove the bolt. Move reel by hand into the respective position. Slide bolt in the new position through reel-support and connection of cylinder and secure with security ring.

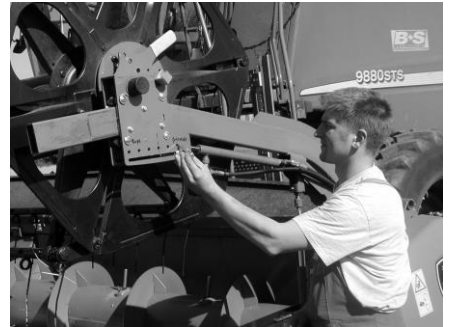

Install bolt into the cart

Backfitting into “Grain” – position is performed in reversed order.



Two icons help to find the right position at the reel-cart:
Grain
Oil Seed Rape



Adjusting Auger Height Hydraulically

Loosen the sprocket support nut M16
Loosen nuts M 16
Loosen hex head bolt M16 of sprocket.



Push sprocket support upwards. And fix it with the bolt in the upper position by putting the bolt (A) into bottom hole of the sprocket support

A

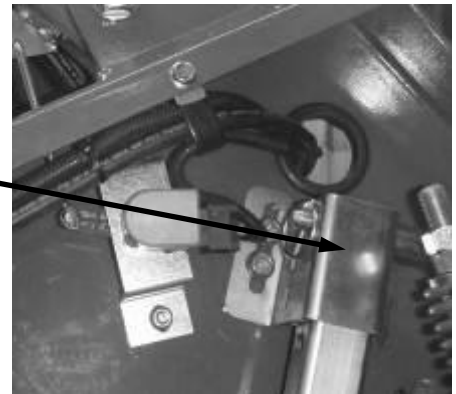

Set pump control lever to “lift”-position and lift auger up to maximum height/level.



Adjusting Auger Height Hydraulically

Install security plates (A) on both sides and secure with a circlip.

A



Stand-by-position of both security plates (A) at platform

(Right side of the platform)



(Left side of the platform: drive side)



Set pump control lever to the "lower"- position so that the auger comes down to the security plate. Leave pump control lever in this position. And set the system under pressure.



Adjusting Auger Height Hydraulically

Check tension of auger chain and if necessary adjust it with the threaded rod. Tighten the sprocket holder (nut M16).



Tension the chain only if necessary. The automatic chain tensioning is normally sufficient (series as of 2008). Tension the chain for conveyor belt drive by turning down the sprocket (when tightening the sprocket in the next step, the chain gets additional tension so do not tension too hard).



Tighten the sprocket.

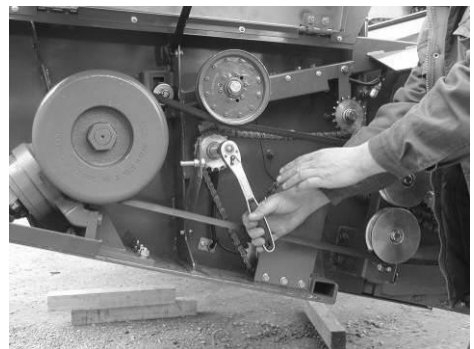

Adjusting Auger Height Hydraulically

- Adjust the outer chain (canola seed).

Loosen the sprocket (look the following picture) and adjust the chain. (When tightening the sprocket the chain tightens, so don't adjust the chain to tight)

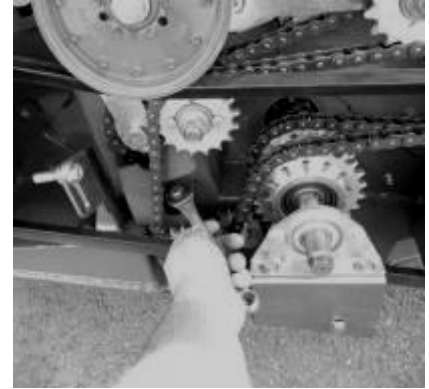

Loosen/Tighten the sprocket

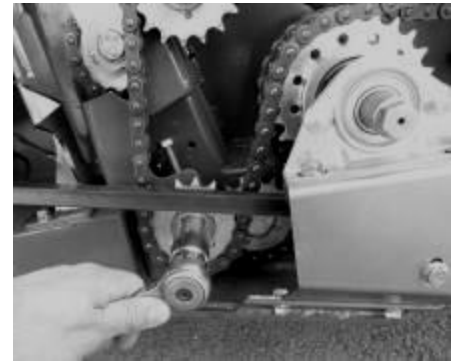

Caution:

Make sure that all bolts are tightened and check the tension of both chains. All chains / sprockets have to be turned manually to make sure that the chain tension is right in every position. Chains which are too tight could cause chain- and bearing damage! Check if safety plates are in place and the pump control lever is in the "lower" position.

Important:

If you want to lower the auger you have to do the same steps in reverse order.

Adjusting Rear Stripper (Oil Seed Rape-Stripper) (618-630)

Loosen stripper bars M 16 nut of the eyebolts (16 Ft, 18 Ft, 20 Ft, 22 Ft 4 screws each, and 25 Ft und 30 Ft 6 screws each) and turn back counter nuts.



Push the stripper bar as much forward as possible.

Tighten the nuts and cover the hole with the rubber washer.



Caution:

**Make sure that all bolts are tightened and check the tension of both chains.
All chains / sprockets have to be turned manually to make sure that the chain tension is right in every position.**

**Chains which are too tight could cause chain- and bearing damage!
Check if safety plates are in place and the pump control lever is in the "lower" position.**

Important:

If you want to lower the auger you have to do the same steps in reversed order.

Adjusting Rear Stripper (Oil Seed Rape-Stripper) (635)

Following Adjusting Auger Height Page 38

1. Remove the clips of each locking pin and remove all pins.



2. Lift up the stripper by using the pump lever, and fix it by using the locking pin and the clip in each bracket.

Please repeat these steps on the other side of the header

Note:

To Lift up the stripper is only necessary in very hard harvesting Conditions. (Lot of soil contamination or in very humid condition)



If there are some difficulties to insert the locking pin, adjust the Locking plates.



Safety Appliances/Devices

Safety Stop for Platform Raising Cylinder

Caution:

Before working under the platform, raise it fully and put safety stop (A) on the hydraulic cylinder.

Lower safety stop (A) onto the hydraulic cylinder rod.

(A)



Setting the Safety Stops on th Reel Raising Cylinder

Caution:

Lower both safety stops (A) when working under or on the reel.

Fully raise reel.

Unhook stop (A) from storage clip, lower stop completely and ensure lock snaps over cylinder rod.

Set safety stop on other end.

(B)



Skid Plates with HEADERTRAK

Special Skid Plates for automatic Header control (AHC=Automatic Header Control), are installed as standard. Skid plates contact the ground up to a maximum height of 280 mm and control cutting height and lateral tilt of platform.

Number of skid plates: up to 6.10 m => 2 pieces
up to 6.70 m => 3 pieces



Note:

The calibration with three skid plates is performed according to the John Deere specifications.

Addresses in E01:

22 left hand sensor
24 sensor in the middle
26 right hand sensor

Addresses in LC1:

28 left hand headertrak sensor
29 headertrak sensor in the middle
30 right hand headertrak sensor

Addresses in LC1 MY2012:

21 left hand headertrak sensor
22 headertrak sensor in the middle 1
23 headertrak sensor in the middle 2
24 right hand headertrak sensor

Basic Setting of Reel

Basic Setting of Reel

Important:

Cutterbar fore-and-aft setting must be set before the reel is set to its minimum height.

1. Lower the reel all the way down.
2. Loosen locknut (A).
3. Turn cylinder rod (B) to raise or lower the reel. Ensure both ends of reel are set equally and that clearance between reel tines and knife meets specification.



B

A

Specification

Reel Tines to Knife-Minimum clearance (30' cutting platform)..... 45 mm

Reel Tines to Knife-Minimum clearance (22' to 25' cutting platform)..... 35 mm

Reel Tines to Knife-Minimum clearance (14' to 20' cutting platform)..... 45 mm

4. Tighten the locknut.

Adjusting Reel Tine Position

Caution:

Shut off the engine before working on the reel.

Pull out and secure the locking pin (A).

On 25' and 30' cutting platforms, go to the other end of the reel and release the lock there as well.

Turn handle (B) to set the reel tines to the desired angle.

Return to original end and set accordingly.

Once the adjustment has been completed, insert locking pin (A) to maintain the setting.

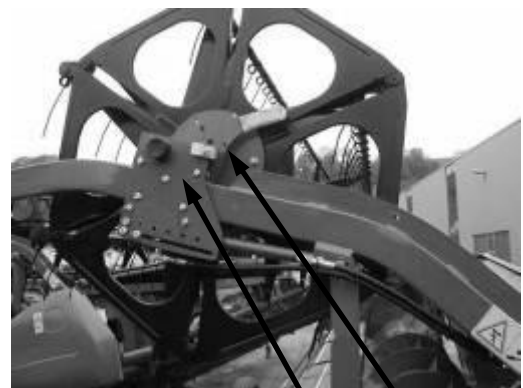

A

B

Basic Setting of Reel

Basic Setting for Reel Raising Cylinder

To adjust reel raising cylinder, remove pins (A) on both sides, extend or retract cylinder rods to align hole with desired position, and install pins.

(A)

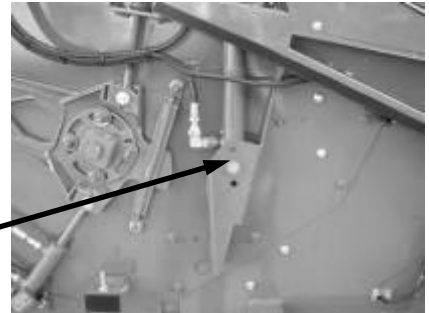

Note:

The cylinders have to be adjusted if they are not extended evenly when working. For that purpose the hydraulic system must be bled. That happens with aid of the bleeding screw (B) on the left hand reel raising cylinder.

(B)



See Page 85

„Reeloperation“

For a further improvement of the crop flow and a reduction of the wear of the knife and the knife drive elements it is also commended to use the reel when working with the PremiumFlow-header in standing crops. Even when the crop flow without using the reel seems to be optimal, there will be the so called double-cut of the cornstalks in the range of the knife. This means an already cut cornstalk could be caught a second time by the knife and cut twice. This leads to a higher power requirement of the knife drive and a higher wear of the knife.

Note:

For reasons listed above we recommend to support the crop flow active in the range of the knife by using the reel when working with the PremiumFlow-header.

Crop Dividers

Crop Dividers

Long and short crop dividers are available for a variety of crop and conditions. The following crop divider combinations are available:

- Long crop dividers on both sides
- Short crop dividers on both sides
- Long crop divider on right side, short one on left side
- Long crop divider on left side, short one on right side

Short crop dividers are preferred in arid areas

For transporting on the platform, crop dividers have to be removed. (See "Installing Crop Dividers" below)

Transport Position

For transporting the cutting platform the crop dividers must be removed. Crop dividers will be transported either within the cutting platform or attached to the trailer. (A,B)

Operating Position:

Crop dividers in expanded position (A,B)

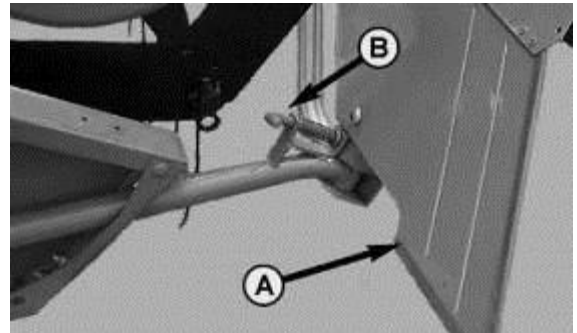
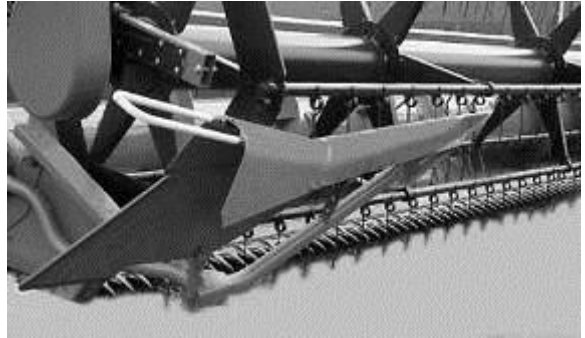

Installing Crop Dividers

Lower cutting platform to normal operating position. Install crop divider support tube (A) through divider opening (B) and retain in top or bottom hole with cap screw, washer and nut (C). Loosen two nuts (D), lift crop divider and shift adjusting plate (E) as needed to required height. Tighten nuts.

- A- Support tube
- B- Divider opening
- C- Nut
- D- Nuts (2pcs.)
- E-adjusting plate

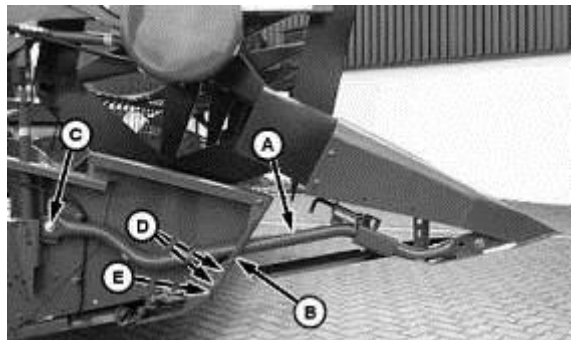

Crop Dividers

Adjust the inside divider the short crop divider

- A- Nuts
- B- Fender

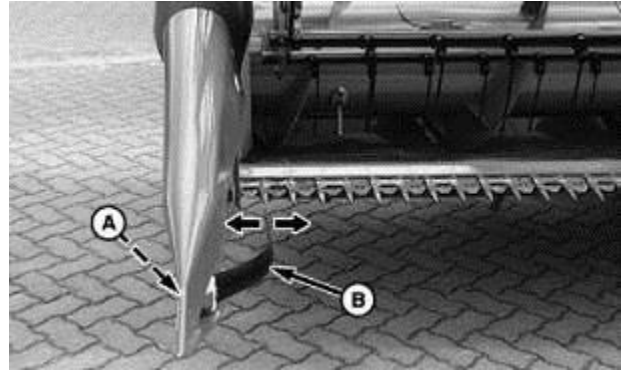

Adjust the inside divider the long crop divider

Dismantle T-screw (A) and handle (B) and adjust the inside divider (C). Fix T-screw and handle.

- A- T-screw
- B- Handle
- C- Inside divider

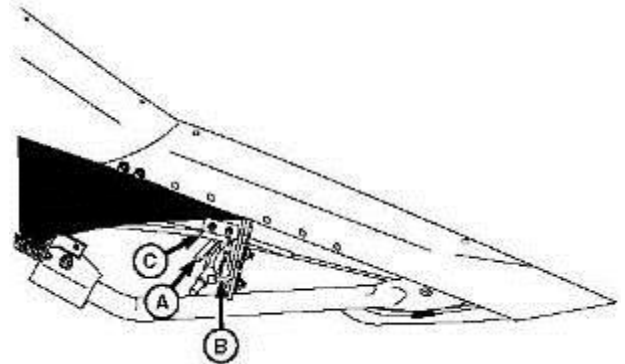

Crop Dividers

Attach the long outside divider

Fix the bracket (A). Hook the front of the long outside divider (B) in the front of the crop divider (C). Save the grab handle (D) with screw (E) in the bracket (A). Save the back end of the divider with a locking pin (F) on the grab handle. Dismantle the screw (G) and adjust the divider. Fix the screw.

- A- Bracket
- B- Long outside divider
- C- Crop
- D- Grab handle
- E- Screw
- F- Locking pin
- G-screw

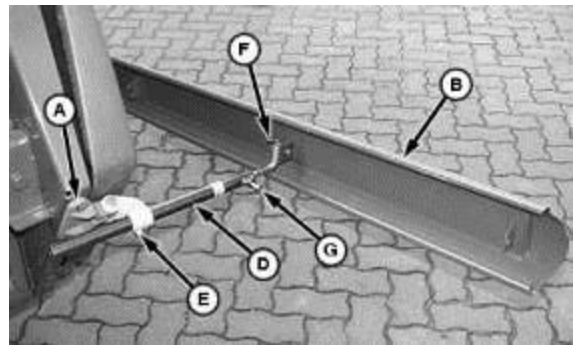
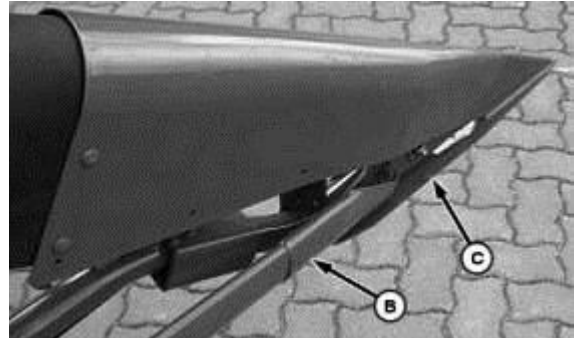

Optionally, the John Deere Crop dividers can be transported or stored in a support on a Zürn trailer



Installing Lifters

Arrangement of Lifting Guards

The arrangement of lifting guards results from the position of the pre-installed attaching points underneath certain knife guards.

Slide lifting guard with its retainer over the relevant knife guard and guide the rear end of the strap into the pre-installed attaching point.

Secure lifting guard with spring pin in bore above the knife guard.

Adapt Lifting Guards to Ground Conditions.

Important:

Check that lifting guards are correctly adjusted by lowering the cutting platform onto a flat surface. Lifting guards should touch the ground when skid plates are 50—100 mm (2—4 in.) above the ground.

If necessary, change position of lifting guard by using one of the two other bores to secure spring pin. This alters the height of the lifting guards.



Knife Protection Guard

Knife Protection Guard

A V-profile knife protection guard must be used during transport and when the cutting platform is stored (A).

Slide the knife protection guard over the tips of the knife guards or over the tips of the lifting guard, and secure with spring (B).

A- Knife Protection Guard

B- Spring clip

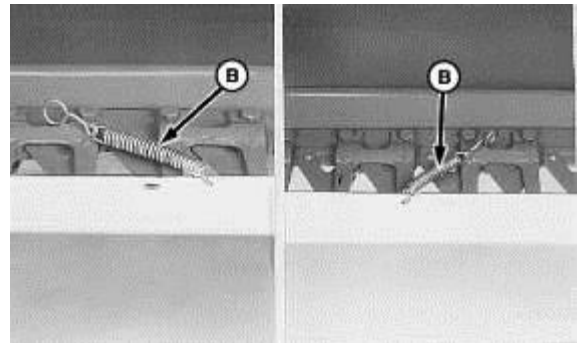
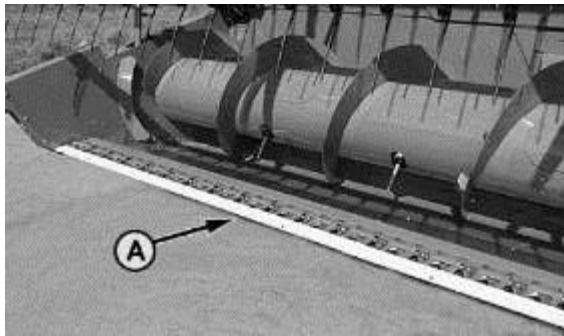

Adjusting Angle of Tilt of the Cutting Platform

Tilt adjustment is used to set the correct relationship between cutterbar/skid plates and ground. It should be set so that skid plates are parallel to groundline when contacting the ground.

Platform tilt is adjusted by changing the angle of the feeder house tilt frame. See combine Operator's Manual for procedure to adjust feeder house fore/aft tilt frame.

Adjusting Auger Height

Adjusting Auger Height

Caution:

Engine must be off and key removed before working on auger. Disconnect driveshaft from feeder house, put in storage position and remove knife drive belt to keep knife stationary before checking clearance along full length of auger by hand.

Important:

Before making any adjustments, raise platform until full weight of platform and reel is supported by the combine feeder house.

For most conditions, adjust auger height to give a minimum clearance of 3 mm (0.12 in.) between flighting and floor or floor strippers.

Important:

Auger fingers must clear floor by a minimum of 20 mm.

On right-hand side of platform, loosen nuts and turn Nut to raise and lower auger.

On left-hand side of platform, loosen auger drive chain idler and nuts, and turn Nut to raise and lower auger.

Retighten nuts.

Check the tension of the auger drive chain.

All Premium-Flow platforms are equipped with a hydraulic auger height adjustment as standard. For that reason the adjusting described above might be limited.

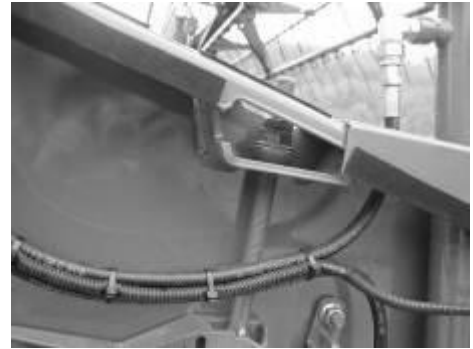

Adjusting Auger Finger Timing

Caution:

Engine must be off and key removed before working on auger.

Important:

Before making any adjustments, raise platform until full weight of platform and reel is supported by the combine feeder house.



1. Loosen four flange nuts on the right-hand end of auger.

Note:

Nominal timing is when maximum finger extension occurs in the fully forward and horizontal (3 o'clock as viewed from the right-hand end) position.

2. Rotate timing casting clockwise to advance or counter clockwise to retard timing.
3. Tighten nuts to specification.

Specification

Nuts-Torque 115 N•m (85 lb-ft)

Important:

Rotate auger by hand to check finger clearances.

4. Adjust auger height if necessary.

Specification

Auger Finger-to-Floor- Clearance 20 mm

Adjusting Auger Fore/Aft

Caution:

Shut off engine and remove the key. Disconnect driveshaft from feeder house and put it in storage position. Remove knife drive belt to keep knife stationary.

1. Loosen nuts (A).
2. Loosen or tighten nuts (C) and (B) to gain desired auger position.

Note: Check auger chain tension (See "Adjust Auger Chain").

3. Tighten nuts (A- C) and auger drive chain idler (See „Adjust Auger Chain”).
4. Repeat on opposite side of platform.

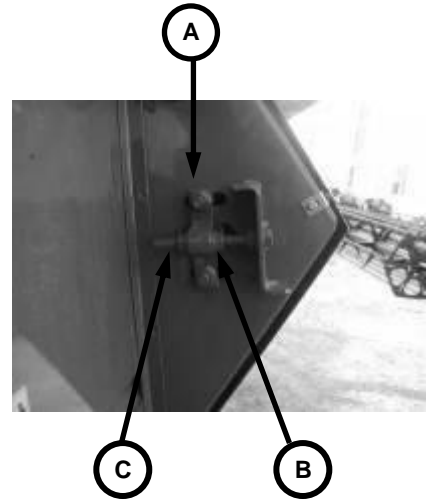

Important:

Rotate auger by hand to check clearance between fingers and platform floor.

Adjusting Rear Stripper

If the auger is too far from the stripper, material can be carried around the auger and will not be evenly fed into the feeder house.

Check stripper clearance with the platform raised.

Loosen eye screws and slide stripper so there is 3 mm (1/8 in.) clearance between auger and stripper. Rotate auger by hand to check clearance as screws are tightened.

The adjustable stripper bars are reversible to provide additional wear life.



Adjusting Auger Chain

Note:
Cutterbar drive belt removed for clarity.

Loosen nuts (A) and (B) and slide idler assembly (C) down with the help of the adjusting screw (C) to tighten chain. Tighten nuts (A) and (B).

Note:
After adjusting the idler assembly, rotate the auger through at least one revolution and at the same time check the tension of the chain.

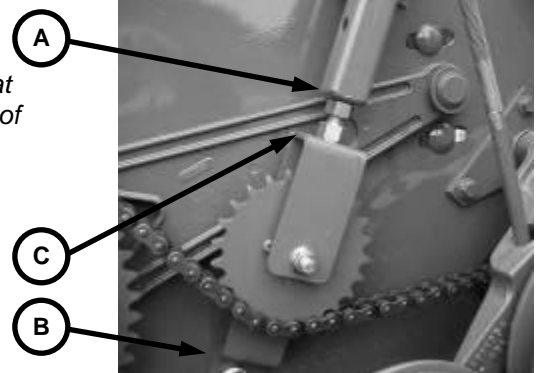

Chain Tension of Belt Drive

The chain for the belt drive is automatically tensioned. The tension force can be changed via three cross-head screws on the upper side of the chain tensioning device. According to requirements, one or three springs can load the chain. Instructions are stuck on the chain tensioning device.

Tension the chain with the chain tensioner (B) so that on the colour scale of the automatic chain tensioning device 5 mm of the yellow area can be seen. For this purpose, loosen the nuts (C), adjust the chain tension with (B) and tighten nuts (C) again.

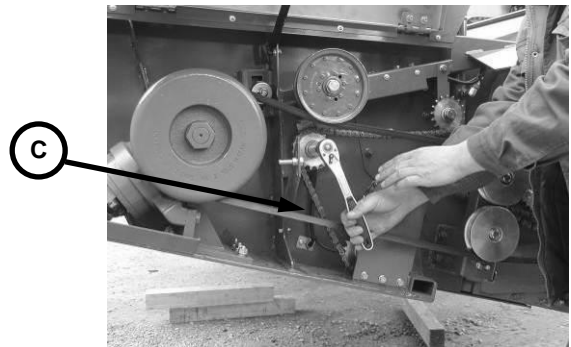
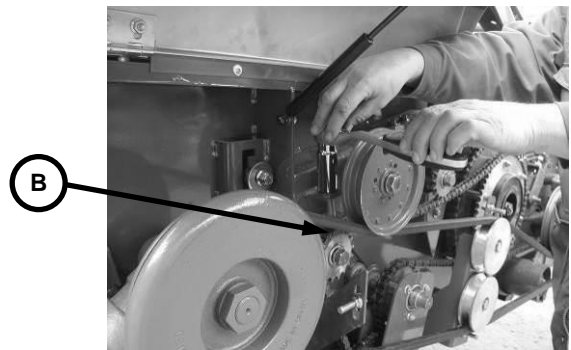

The belt chain drive is equipped with automatic chain tensioners you should check the tension weekly and if necessary adjust the tension.

- Adjust the inner chain (cereals).

Loosen the sprocket (look the following picture) and adjust the chain. (When tightening the sprocket the chain tightens, so don't adjust the chain to tight)



Chain Tension of Belt Drive

Loosen/Tighten the sprocket

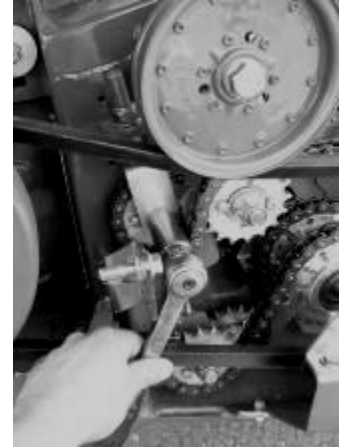

- Adjust the outer chain (Oil Seed Rape- Sunflowers),
Loosen the sprocket (look the following picture) and adjust the chain. (When tightening the sprocket the chain tightens, so don't adjust the chain to tight)

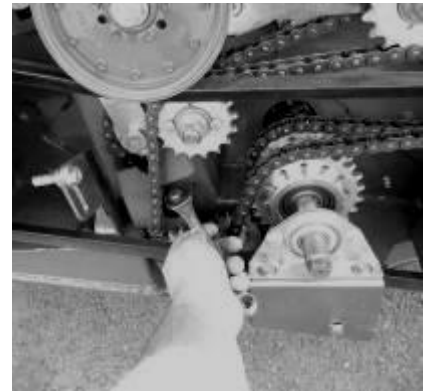

Loosen/Tighten the sprocket

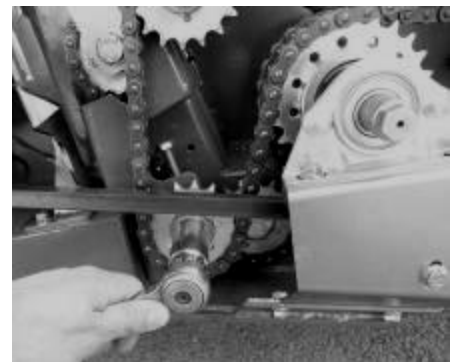

Auger Floor Stripper Extension

Floor strippers help to stop material from carrying over the auger. Floor stripper extensions are provided and can be removed if needed to improve material distribution.



Auger Anti-Wrap Shields

These anti-wrap shields reduce the possibility of straw wrapping around the auger shaft.

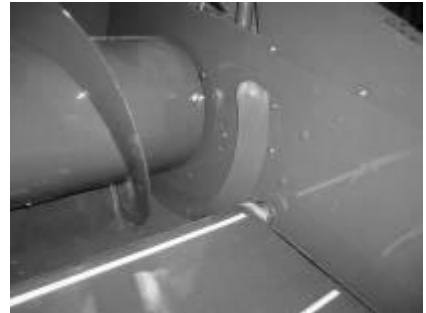

Cleaning underneath the Belt Body

Lift up the reel and secure it with reel support (A).

A



Remove the stainless steel covers on both sides of the belts by removing the bolts (M8x12) and split the stainless steel cover as shown in the picture.



Cleaning underneath the Belt Body

Lift up the belt body and lean it backwards on the auger.

Clean underneath the belt body with a broom or by hand.



Caution:

Make sure the “fixed sealing” is movable both backward and forward and sideways.

Important:

Do a test run before installing the covers. Make sure, that no belt is running against a sealing and that the sealing have clearance on both sides.

Caution:

Please pay attention that there is no gap between the two covers when they are mounted and the sealing lips are in contact. Take note that the sealing lips of the back cover doesn't overlap the lips of the front cover, the lips should be aligned. The covers should be remounted with the lips in the existing tracks on the belts. The sealing lips have to be in contact with the Front and the back of the belt, should there be a small gap, please bend the covers by hand to make sure that this gap is closed

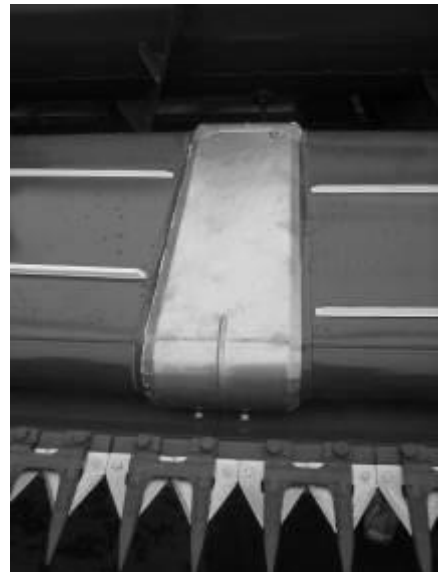

Lubricants, Oil and Capacities

Knife Gear Oil

Use oil viscosity based on the expected air temperature range during the period between oil changes.

The following oils are preferred:

- John Deere GL-5 Gear Lubricant
- John Deere EXTREME-GARD™
- John Deere HY-GARD™ (For Adjusting Auger Height, Capacity circa 2 l)

Other oils may be used if they meet API Service Classification GL-5.

Grease

Use grease based on NLGI consistency numbers and the expected air temperature range during the service interval.

The following grease is recommended:

- John Deere SD POLYUREA GREASE (TY6341)

Other greases may be used if they meet the following:

- NLGI Performance Classification GC-LB

Important:

If grease fitting is missing, replace immediately. Clean fittings thoroughly before using grease gun.

Product Number	Description
TY6341	Multi-Purpose, High-Temperature Extreme Pressure Grease, especially effective in rolling contact applications.

Lubricants, Oil and Capacities

Alternative and Synthetic Lubricants

Conditions in certain geographical areas may require lubricant recommendations different from those printed in this manual.

Some John Deere brand coolants and lubricants may not be available in your location.

Synthetic lubricants may be used if they meet the performance requirements as shown in this manual.

The temperature limits and service intervals shown in this manual apply to both conventional and synthetic oils.

Re-refined base stock products may be used if the finished lubricant meets the performance requirements.

Mixing of Lubricants

In general, avoid mixing different brands or types of oil. Oil manufacturers blend additives in their oils to meet certain specifications and performance requirements.

Mixing different oils can interfere with the proper functioning of these additives and degrade lubricant performance.

Lubricant Storage

Your equipment can operate at top efficiency only when clean lubricants are used.

Use clean containers to handle all lubricants.

Whenever possible, store lubricants and containers in an area protected from dust, moisture, and other contamination. Store containers on their side to avoid water and dirt accumulation.

Make certain that all containers are properly marked to identify their contents.

Properly dispose of all old containers and any residual lubricant they may contain.

Lubrication Charts, Periodic Service

Caution:

Never service or lubricate the cutting platform while the combine engine is running.

Important:

Recommended service intervals apply to average conditions. Service more often if platform is operated under adverse conditions.

Lubricate with John Deere Multipurpose SD Polyurea Grease High Temperature/Extreme Pressure lubricant or an equal SAE Multipurpose High Temperature Grease with Extreme Pressure (EP) performance at the intervals (in hours) shown with the lubricating symbol.

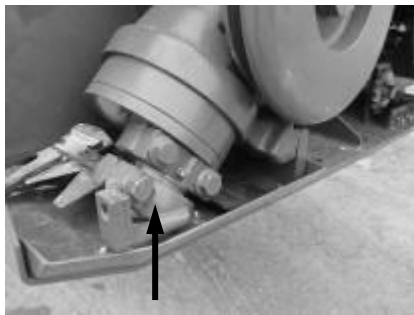

Lubricate Knife head bearing
(every 50 hours)

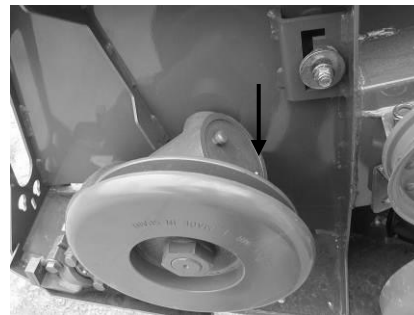

Lubricate cutterbar drive
(5 strokes of grease gun every 50 hours of operation)

Important:

It is normal, that the knife drive body is getting very warm when operating. DO NOT overuse lubricant to lower the temperature. Defective sealed could be the consequence.

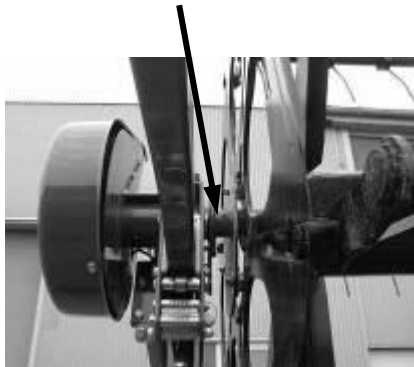

(both sides) Lubricate body of reel shaft
(5 strokes of grease gun or until grease is escaping)

Table of Service

When	What	How
Each day	Clean space between belts from the bottom	Reach into the cleaning opening from the bottom and remove dirt and straw
Weekly	Clean space between belts from the top	Remove stainless-steel plate and clean the space between. Eventually scratch out persistent dirt with a screwdriver.
After Oil Seed Rape harvesting or if required	Clean platform floor under the belts	Loosen the belts and lift them up. Clean with a broom the entire ground.
After harvest season or if required	Clean Belt Body completely.	Loosen belt body and remove completely. Then demount belt body and clean it.

Troubleshooting

Cutterbar difficulties

Symptom	Problem	Solution
Grain shatters ahead of cutterbar	Reel Speed not matching to ground speed	Adjust reel speed so that the reel moves the crop evenly. In standing crops, reel speed should be equal to or slightly less than combine ground speed. In down and tangled crops, reel speed should be greater than combine ground speed.
	Reel set too low	Raise the reel.
	Combine ground speed to high	Reduce combine ground speed to avoid that crops are not shattered by reel
Cut crop accumulates and falls ahead of cutterbar; loss of grain heads at cutterbar	Reel set too high	Set reel low enough to sweep material away from the cutterbar, allowing it to be picked up evenly by the auger.
	Excessive clearance between auger and platform floor	Adjust auger to give 5—10 m (0.2—0.4 in.) clearance in grain crops and 20—30 mm (0.8—1.2 in.) clearance in crops such as Oil Rape Seed and soybeans. Re-adjust feeder fingers as appropriate.
	Platform to high, cutting crops to	Lower platform that crops are cut high enough and be picked up evenly by the auger
	Reel speed to low	Raise reel speed
	Mat of soil/dirt builds up on angle section	Clean angle section
	Mat of green material builds up on cutterbar	knife with too thickly serrated knife sections

Troubleshooting

Down and Tangled Crops Difficulties

Symptom	Problem	Solution
Too much material entering combine	Cutting platform set too low	<p>Use crop lifters in down and tangled crops.</p> <p>Raise platform as high as possible.</p> <p>Reduce ground speed.</p> <p>Use knife with finely serrated knife sections.</p> <p>Check the angle at which the cutting platform is tilted.</p>

Feeder House Difficulties

Symptom	Problem	Solution
Uneven or bunched feeding of crop to bottom feeder conveyor drum.	<p>Auger too far from platform floor Reel set too high.</p> <p>Grain building up on cutterbar.</p> <p>Set reel as close as possible to cutterbar and auger.</p> <p>Platform drives belt slipping.</p>	<p>Adjust auger to suit crop. Move reel back and then down.</p> <p>Lower reel.</p> <p>Spring-loaded idler must be free and tight against belt.</p>
Difficulty conveying short crop from platform auger to feeder chain house	<p>Auger too far from feeder conveyor. Feeder house conveyor chain does not convey properly.</p>	<p>Adjust auger rearward.</p> <p>See "Troubleshooting—Feeder House" in combine Operator's Manual.</p>

Troubleshooting

Auger Difficulties

Symptom	Problem	Solution
Auger wrapping in tangled and weedy crops	Poor delivery of crop from auger to feeder house	Remove paint and rust from auger finger area. Install extended pitch auger flight extensions and remove center auger fingers.
Poor delivery of crop to auger.	Paint and rust on platform floor behind cutterbar	Remove paint and rust.
	Reel tines pitched too far	Reduce pitch (angle) of tines.

Cutting Difficulties

Symptom	Problem	Solution
Ragged an uneven cutting of crop	Cutterbar plugged with material	Adjust reel to sweep material off cutterbar melt Check platform and feeder house drives (see Combine Operator's Manual).
	Various parts of cutterbar worn, damaged or broken	Check and replace all worn or damaged parts. Check guard alignment and, if necessary, align for a smooth cut.
	Cutting edge of guards not close enough or parallel to knife sections	Adjust guards.

Troubleshooting

Belt Difficulties

Symptom	Problem	Solution
Belt does not turn	Belt tension too low (< 15 Nm, counter clockwise!!)	Check belt tension
	Soil underneath the belt	Raise belt body and clean it
All belt segments do not turn	Chain is broken	Install new chain for belt drive system
	Coupling disc broken	
	Slip clutch broken	Provide coupling with new friction plates or renew completely
	Slip clutch adjusted falsely	Check torque of the slip clutch
	Dirt underneath the belt body is so high that torque of slip clutch is not sufficient	Lift up the belt body and clean underneath

Reel Difficulties

Symptom	Problem	Solution
Reel wrapping in tangled and weedy crops	Incorrect reel setting	Lower reel and set it as far forward as possible.
Reel carrying straw around	Reel tines pitched too far	Reduce pitch (angle) of tines.
Green material not feeding from cutterbar to auger	Reel tines pitched too far	Reduce pitch (angle) of tines.

Service

Safety Stop for Platform Raising Cylinder

Caution:
Before working under the platform, raise it fully and put safety stop (A) on the hydraulic cylinder.

Lower safety stop (A) onto hydraulic cylinder rod.



Setting the Safety Stops on the Reel Raising Cylinder

Caution:
Lower both Safety Stops (A) when working under or on the reel.

Fully raise reel.

Unhook safety stop (A) from storage clip, lower stop completely and ensure lock snaps over cylinder rod.

Set safety stop on other end.



Adjusting Reel Speed Ratio Sensor

Remove screws and shields on the right side of the reel.

Loosen two lock nuts (A) and adjust speed sensor (B) until it touches pulse sending unit (C), then back it off ½ turn.

Rotate the reel a couple of turns by hand to be sure there is no interference. Tighten lock nuts (A) and replace shield.

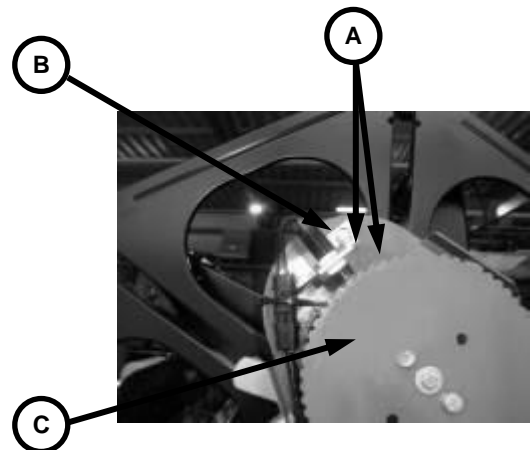

Replacing Cutterbar Knife

Stainless steel shield - plastic shield.

Turn lock (A) counter clockwise using screwdriver and open left-hand end shield in the order



Lift up on tensioner arm shave handle (A) to relieve belt tension. Remove drive belt (B).



Remove knife drive plate (A) on the right side



Remove nuts and screws from knife head shield (A).

Manually rotate knife drive (Knife head) until cap screws (B) is accessible.

Remove cap screws (B) to disconnect knife from drive.

Caution:

To reduce risk of personal injury, always wear gloves when handling knives, and stand to the rear when removing or installing knife.

Pull knife through guards until bearing assembly is separated from knife drive.

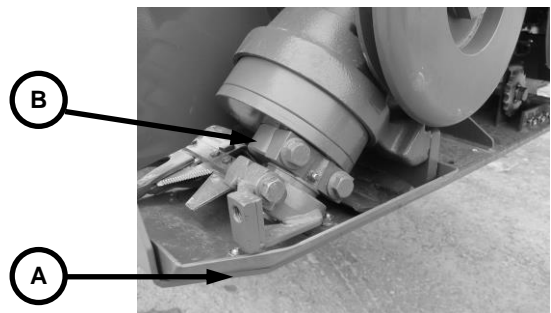

Replacing Cutterbar Knife

Remove cap screw (A) from knife head.

Using a pair of self-locking pliers, apply light pressure to relief area (B) of knife head to expand it.

Remove bearing assembly (C).

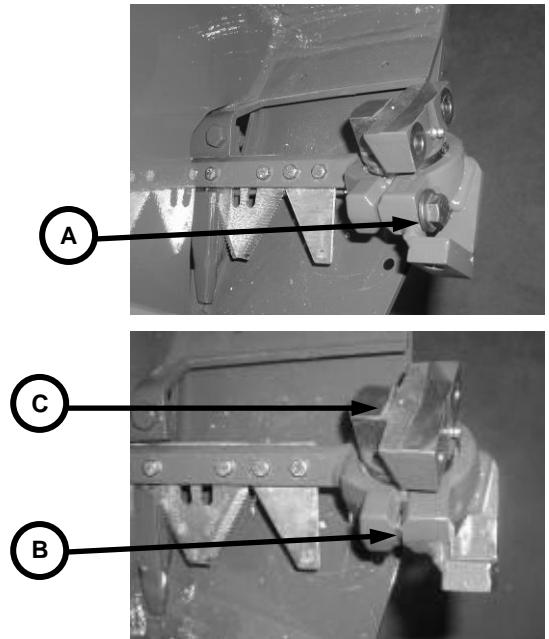

Remove spanner ring

Important:
Spanner ring maintains a smooth drive operation and proper knife head alignment. Replace spanner ring any time a major component failure has occurred in knife head or knife drive gearbox area, or any time the system has been previously operated with improper knife head alignment.

Remove spanner ring.

Install new spanner ring in knife head of new knife to be installed.

Install bearing assembly in knife head.

Remove self-locking pliers.



Replacing Cutterbar Knife

Install cap screw from knife head but do not tighten at this time.

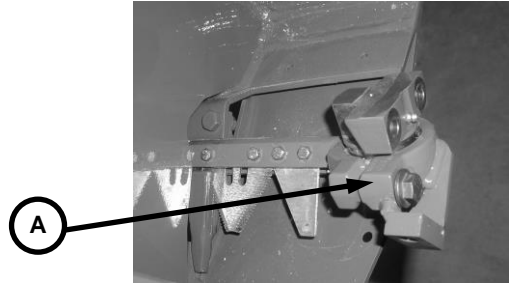

Caution:

To reduce risk of personal injury, always wear gloves when handling knives, and stand to the rear when removing or installing knife.

Important:

Tighten cap screws (A) to specification.

Push knife back into guards until bearing contacts drive. Ensure drive is positioned to accept bearing, lightly tap components together. Tighten cap screws (A) to specification.

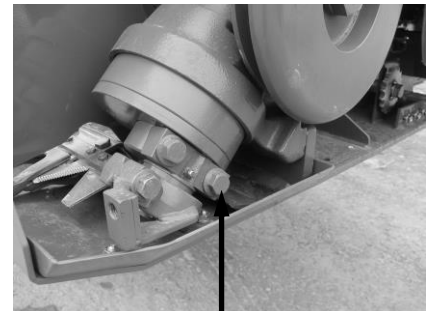

Specification

Knife Head Drive Cap Screws-Torque

..... 130 N•m(96 lb-ft)

Replacing Cutterbar Knife

Important:

Setting of cutterbar head is critical. If cutterbar head is not set correctly, binding and gear box failure may occur.

Set vertical position and angle of knife head (A), so cutting surface is centred in guard slot and is parallel to bottom of guard slot at (C).

Note:

Make sure knife head (A) does not contact bearing shield (B).

Check fore/aft gap distance (D) at both locations between knife back (E) and first guard to ensure a gap exists. If there is no gap see "Aligning Knife Head and Knife Drive Alignment" in this section.

A- Knife Head

B- Bearing Shield

C- Gap

D- Gap (Two Locations)

E- Knife Back

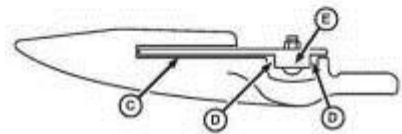
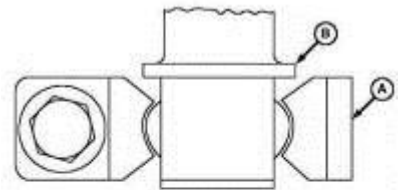

Note:

While tightening bolt to specification use a pry bar as shown to avoid twisting of the cutterbar head (A) and loss of knife head settings.

Tighten cap screw to specification.

Specification

Knife Head Assembly Cap

Screw Tor..... 130 N•m (96 lb-ft)

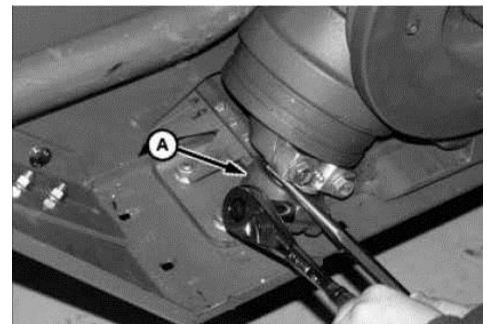

Verify that the knife section is still properly positioned in the first guard slot after the knife head bolt is fully tightened.

Replacing Cutterbar Knife

Install knife head shield (A) and tighten flange nuts.



Lift up on tensioner arm sheave handle (A) and install drive belt (B).

Close left-hand end shields in order plastic shield – stainless steel shield

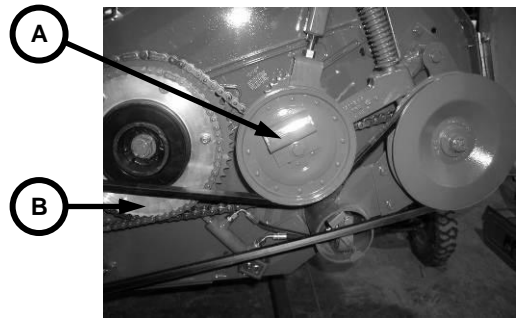

Aligning Knife Head and Knife Drive Alignment

Note:

Timely replacement of worn knife guards and sections will help maintain good cutting performance while reducing loads and extending the life of drive components.

Proper adjustment and alignment of knife guards and drive components will also improve cutting performance and reduce system loads.

Proper knife head and knife drive alignment is critical in achieving effective cutting performance and drive durability.

Use the following steps to check/adjust knife head and knife drive alignments: Start the engine.

Raise reel and lower lift cylinder safety stops (A) on both ends of platform.

Support platform with wood blocks.

Set parking brake, shut off engine and remove key.

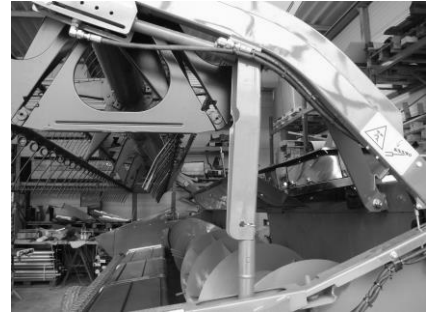

Turn lock (A) counter clockwise using screwdriver and open left-hand end shields in order plastic shield – stainless steel shield

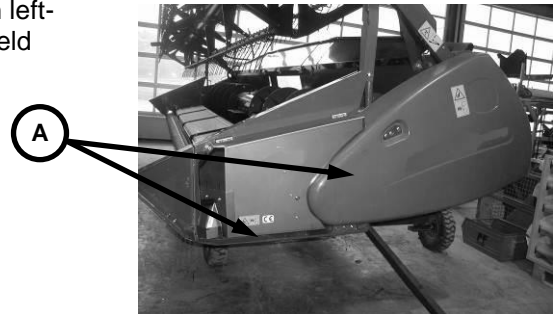

Lift up on tensioner arm sheave handle (A) to relieve belt tension and remove driving belt (B).

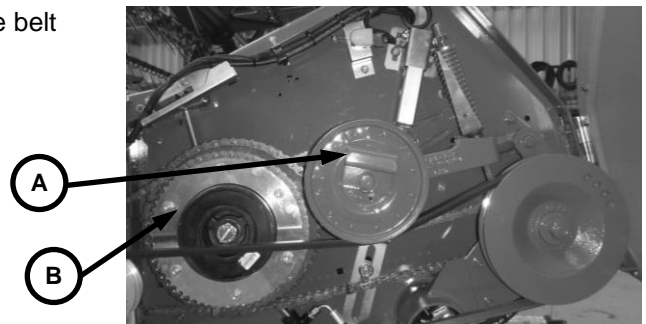

Aligning Knife Head and Knife Drive Alignment

Turn knife drive sheave by hand. Sheave (and knife) should turn easily. If sheave does not turn easily or knife binds during its movement, knife head and knife drive alignment should be adjusted.



Visually inspect the positions (C and D) of the knife section in the first knife guard slot and the knife back (E) fore/aft position in the guard. If there is excessive contact in either location, knife head and knife drive alignment should be adjusted.

- C- Gap
- D- Gap (Two Locations)
- E- Knife Back

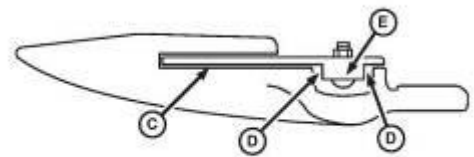

Loosen knife head clamp bolt (A).

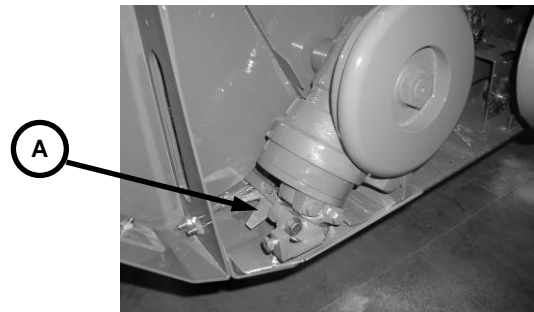

Set vertical position and angle of knife head (A), so cutting surface is centred in guard slot and is parallel to bottom of guard slot at (C).

Note: Make sure knife head (A) does not contact bearing shield (B).

Check fore/aft gap distance (D) at both locations between knife back (E) and first guard to ensure a gap exists. If there is no gap, proceed to reposition the knife gear box, reset vertical position and angle of knife section.



Aligning Knife Head and Knife Drive Alignment

Set vertical position and angle of knife head (A), so cutting surface is centred in guard slot and is parallel to bottom of guard slot at (C).

Note: Make sure knife head (A) does not contact bearing shield (B).

Check fore/aft gap distance (D) at both locations between knife back (E) and first guard to ensure a gap exists. If there is no gap, proceed to reposition the knife gear box, reset vertical position and angle of knife section.

- A- Knife Head
- B- Bearing Shield
- C- Gap
- D- Gap (Two Locations)
- E- Knife Back

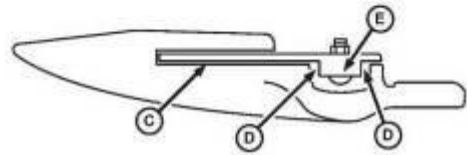
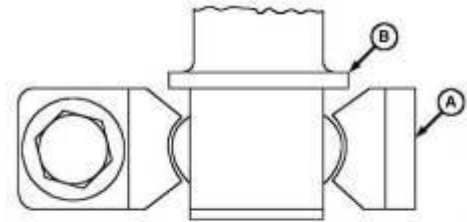

Loosen four gear box mounting bolts (A).

Using a pry bar under gearbox housing (B), Position box to provide knife back fore/aft clearance.

Tighten bolts to specification while holding gearbox to avoid movement.

Specification

Bolt- Torque..... 300 N•m (221 lb-ft)

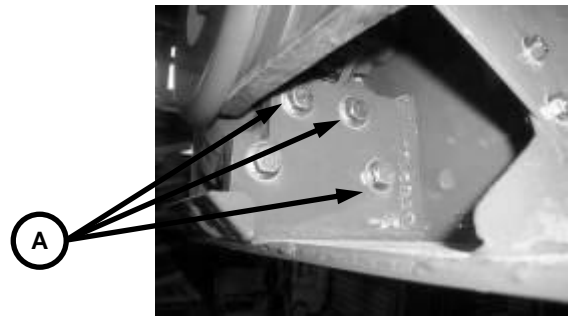

Reset vertical position and angle of knife head (A), and check clearance of bearing shield, and recheck all clearances. Repeat procedure until proper clearance is achieved



Aligning Knife Head and Knife Drive Alignment

Note:
While tightening bolt to specification use a pry bar (=iron rod!!) to avoid twisting of the cutterbar head and loss of knife head settings.

Tighten cap screw (A) to specification.

Specification

Knife Head Assembly Cap Screw
Torque..... 130 N•m (96 lb-ft)

Verify that the knife section is still properly positioned in the first guard slot after the knife head bolt is fully tightened.

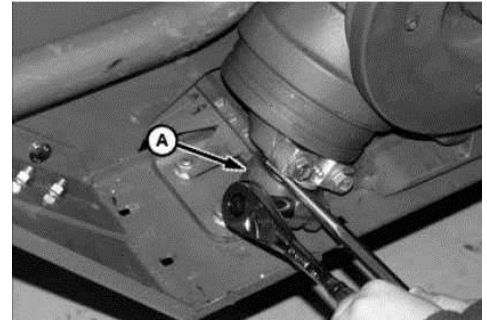

Rotate sheave making sure there is no binding of cutterbar head, knife sections and knife shields. If binding occurs, repeat adjusting steps.

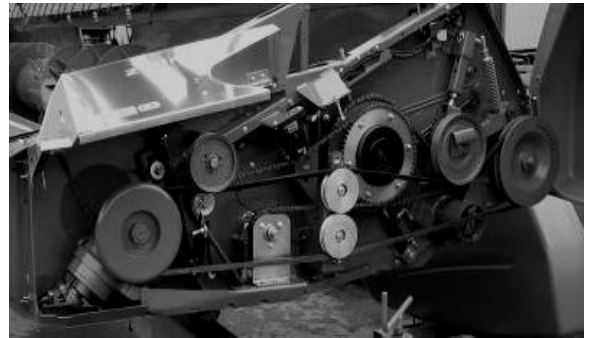

Lift up on tensioner arm sheave handle (A) and install drive belt (B).

Close left-hand end shields in order plastic shield - stainless steel shield

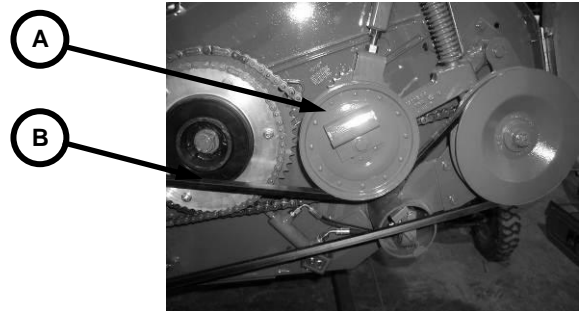

Replacing Knife Sections

Raise reel and set safety stops (A) on both sides of platform!

Remove nuts and cap screws (A) and knife guard (B).

Remove cap screws (C) and knife section.

Install new section. Tighten cap screws (C) to specification.

Specification

Section Cap Screws - Torque

.....18 Nm (13 lb-ft)

Install knife guard and retain with cap screws and nuts.

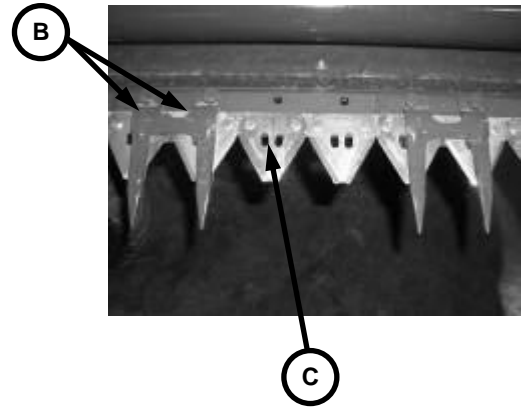

Aligning Guards

Caution:

Always lower both reel cylinder stops when working under the reel.

Align the knife guards to get a shear cut between section and guard. Tighten bolt as each guard is aligned.

Note:

Guard lip must be parallel with shear edge of guard. Note location of knife.

If replacing guards, align new guards to ensure a shear cut.



Replacing Auger Fingers and Retainers

Caution:

Whenever the auger is rotated by hand, the cutterbar will move. Keep hands, feet and clothing away from cutterbar when servicing, inspecting or rotating the auger.

Open left-hand shields.

Pull up on tensioner arm sheave handle to relieve belt tension.

Remove drive belt.

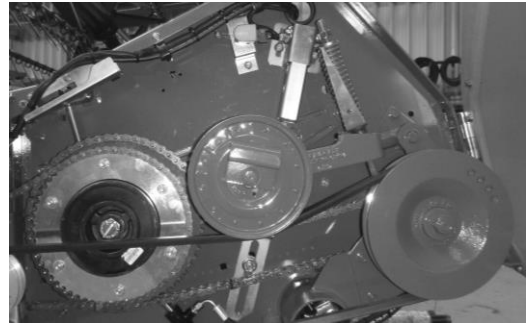

Use JDC-3 or TORX® T-40 driver to remove two TORX screws (A) and guide.

Note:

Order JDC-3 from your John Deere dealer. Use driver with 1/4 to 3/8-in. adapter.

(A)

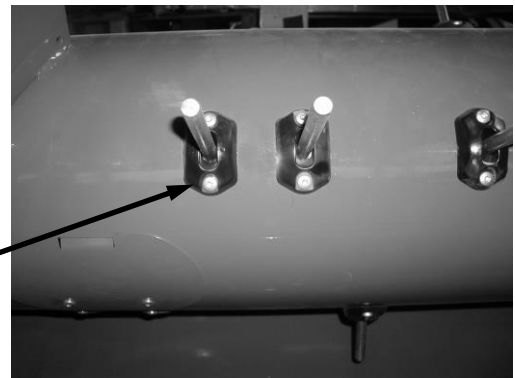

TORX is a trademark of Camcar/Textron

Replacing Auger Fingers and Retainers

Use JDC-3 or TORX T-40 driver to loosen TORX screws and remove access hole covers (A).

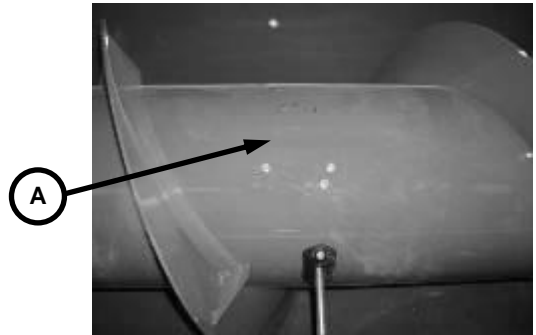

Remove pin (A) and remove broken parts.

Important:
Replace auger finger retainers (B) when replacing auger fingers (C). Make sure fingers are *securely fastened* by pins (A) before replacing access hole cover.

Install new parts and retain with pin (A).

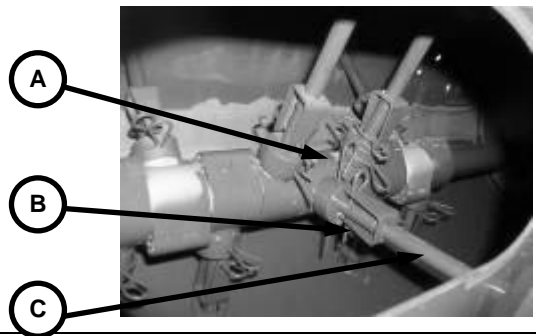

Install access hole covers and retain with TORX screws.



Install guide and retain with TORX screws.

Reinstall drive belt and close left-hand end shields.

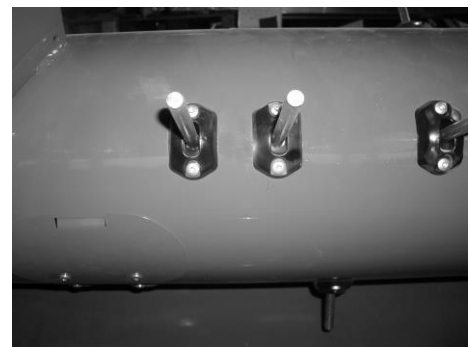

Remove and Install Knife Drive Belt and Checking the Tension

Open left-hand shields.

Pull up on tensioner arm sheave handle (A) to relieve belt tension.

Remove drive belt (B).

Eventually loosen the tension of the belt to remove the belt.

Check tension of belt with "adjusting gauge (C)". The top of the adjusting gauge must be aligned with the top of the spring.

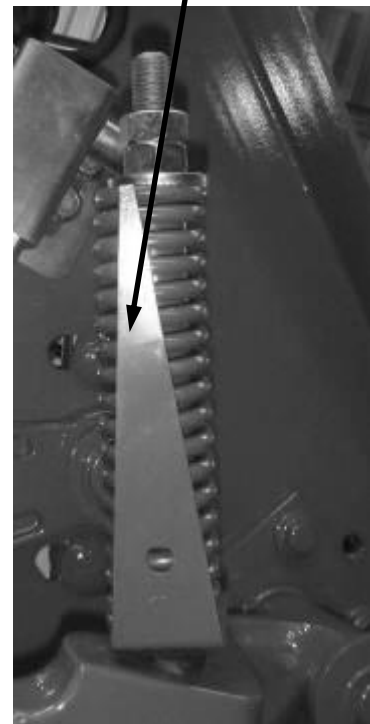
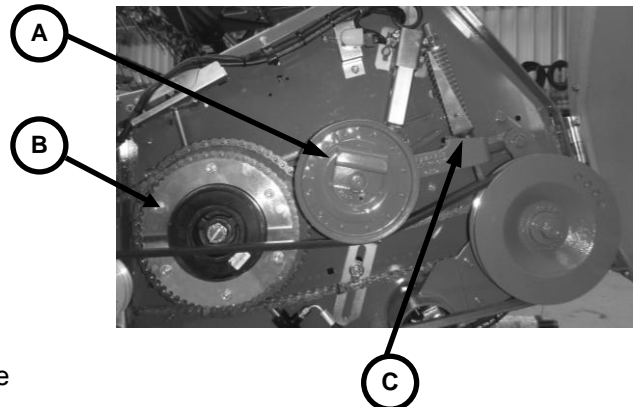

Adjusting Skid Plates for Automatic Header Control

When the cutting platform is lifted up, the sensor plates fall down due to their own weight. Two straps are holding the sensor plate.



If the potentiometer is connected and if the HEADERTRAK system of the combine is in diagnostic address E01-22 (left-hand sensor), E01-24 (middle sensor) or E01-26 (right-hand sensor) (see "Service-Electrical System" section of combine Operator's Manual), the following figures should be shown by the tachometer:

3.5 to 4.5 volts with platform lifted and TASTKUFÉ without ground contact.

0.5 to 1.5 volts with platform completely lowered and TASTKUFÉ completely pushed upward.

Intermediate values should serve as basic adjustment:

4.0 volts (platform raised)

1.0 volts (platform lowered)

The difference between these values should be more than 2 volts.

If values shown by „Visiontrak“ are not within the ranges above, adjust height sensor by loosening the bolts of the sensor and turning it into the right position, until the values are in the right range

Rephasing Reel Lift Cylinders

Always keep reel level with cutterbar. If one end of reel is lower than the other, raise reel to the highest position or lower to the lowest position. When both cylinders have been extended or retracted, return reel to original position and it will automatically be level. If reel is not levelled, there must be air in system and it must be bled out (see "Bleeding the Reel Lift Cylinders" in this section).

Bleeding the Reel Lift Cylinders

If hoses have been disconnected from cylinder, or if reel will not remain level with cutterbar, trapped air must be bled from cylinders and lines. This requires two people.

Caution:

When performing this operation, lower cylinder safety stops.

Open bleed plug (A) in cylinder on left-hand side.

Raise reel and hold switch until escaping oil is free of air bubbles.

Important:

Bleed plug must be tight or air will get into system again.

Tighten plug to specification.

Specification

Bleed Plug- Torque 5 N•m (3.6 lb-ft)



Removing the Belt Body

Bring reel in top position and secure it with the reel support.



Disconnect the stainless steel covers (left hand and right hand side) by loosening the bolts (M8x12).



Removing the Belt Body

Remove the pins 8x40 mm of the divided "Rotex" coupler and remove the bolts of one coupler and loosen the bolts of the other coupler slide back the coupler with the loosen bolts and remove (A) the other one.

Remove the pins 8x40 mm of the "Rotex" coupler and slide back the coupler

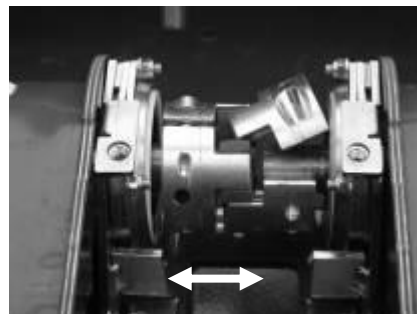

Loosen the Inbus-bolt M12x50 mm (MY2005-2008) and Inbus-bolt M12x25 (MY2009) remove the bolt body



Dismantling the Belt Body

Take out bolts M6x12 mm from the sealing.



Take out bolts M8x55 mm from the locking support.



Remove sealing.



Remove Separation „fix“.



Dismantling the Belt Body

Loosen the spring tension by turning the bolt M24 (A) clockwise.

A



Press the belt body together manually and pull of the rubber belt.

Note:

There are guiding rails at both sides of the rubber belt.



Belt tensioning unit is now laid open. Clean the belt body completely if necessary.



Order of the different belts in the header. The belts have no Running direction; therefore they can be mounted in both ways.

Distance between screws in mm

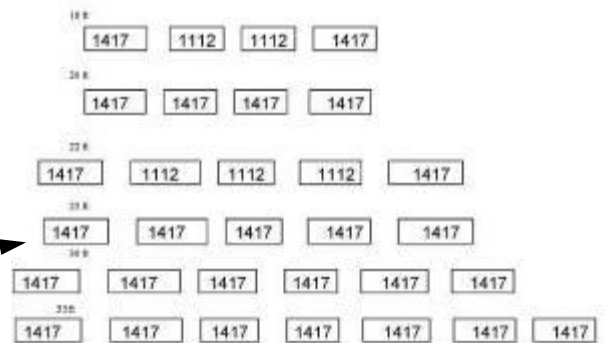

Dismantling the Belt Body

The mounting of the rubber belt is performed in Reverse order.

Belt tension should be 10-12 Nm (counter-clockwise)



Important:

Do not swap left-hand side and right-hand side pivot bearing. Lubricate the flet seals before remounting them (till MY08) with oil (10 W 40). Order from inside (Beltbodyroller) to the outside. Distance washer 3 mm - Flet seal 58/40/4 - pivot bearing - Flet seal 43/25/4 - Plastic washer 52/25,5/2

Pivot bearing MY2009



Caution:

When installing the belt body, there must be a gap of 2,5-3,5 mm between the couplings

If necessary the coupling could be adjusted by taking the other fixing hole which is located 90° turned and with a distance of 1.5 mm.

Please pay attention with the pivot bearings MY2009 that the white plastic spanner ring is close to the bearing seat on both sides of the roll back to make sure the belt body doesn't move sideward.



Dismantling the Belt Body

Caution:

Make sure the “fixed sealing” is movable both backward and forward and sideways.

Important:

Do a test run before installing the covers. Make sure, that no belt is running against a sealing and that the sealing have clearance on both sides.

Caution:

Please pay attention that there is no gap. Between the two covers when they are mounted and the sealing lips are in contact. Take note that the sealing lips of the back cover doesn't overlap the lips of the front cover, the lips should be aligned. The covers should be remounted with the lips in the existing tracks on the belts. The sealing lips have to be in contact with the Front and the back of the belt, should there be a small gap, please bend the covers by hand to make sure that this gap is close.



Pull out the drawer and clean it



Dismantling the Belt Body

Put the special tool on the endings of the front and rear roller and pull the two rollers together. Fix the two rollers by taking the hook, remove the special tool and do the same on the other side.



Fix the two rollers by taking the hook, remove the special tool and do the same on the other side



Storage of the Cutting Platform

End of Season Service

Caution:

Whenever the auger is rotated by hand, the cutterbar will move. Keep hands, feet and clothing clear of the cutterbar and its knives when attempting to rotate the auger manually.

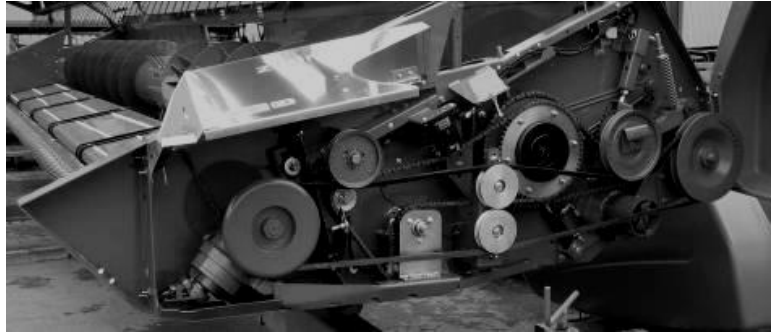

Important:

Do not use high pressure washer spray directly on bearings or any other area that might be damaged by water. Do not use high pressure washer spray to clean the belts!! High pressure water can get past most seals and cause damage. Dry these areas, then lubricate and run platform

1. Clean the platform thoroughly. Chaff and dirt will draw moisture and cause corrosion.
2. Lubricate platform. Grease threads on adjusting bolts.
3. Remove drive belt. Wipe belt clean with a good non-flammable solvent.
4. Paint all parts where paint is worn.
5. Clean belts and service the belt body **(Do not clean the belts with high pressure washer spray)**
6. Store the platform in a dry, protected place.

Beginning of Season Service

1. Clean the platform.
2. Put on belts and check tension.
3. Adjust chains and check tension.
4. Lubricate platform.
5. Go over platform and see that all bolts are tight and cotter pins are spread.
6. Run platform at half-speed and without stainless steel covers for a few minutes.
7. Check belt tension.

Specifications

Cutting Platform Specification

Cutting Platform

Weight	PF618: 2420 kg (without side-knife) PF620: 2540 kg (without side-knife) PF622: 2910 kg PF625: 3180 kg PF630: 3780 kg PF635: 4050 kg
2 pieces of side-knives including holder for platform trailer:	82 kg
Total platform width.....	616: 5358 mm 618: 5815 mm 620: 6425 mm 622: 7035 mm 625: 7949 mm 630: 9473 mm 635: 10997 mm
Total platform length without dividers.....	2450 mm
Cutterbar extension adjustment.....	17°
Cutterbar tilt adjusting range (located on feeder house)	170 mm
Knife drive.....	In-line epicyclic drive
Knife Speed.....	1040 strokes/min.
Width of cut.....	616: 5176 mm (16 ft) 618: 5486 mm (18 ft) 620: 6096 mm (20 ft) 622: 6706 mm (22 ft) 625: 7620 mm (25 ft) 630: 9144 mm (30 ft) 635: 10668 mm (35 ft)
Knife section type	
Cutterbar.....	Fine-toothed high-performance plate
Spare knife.....	Fine-toothed high-performance plate
Reel	
Reel diameter.....	1100 mm (43.3 in.)
Number of reel bars.....	6
Reel speed.....	5— 44 rpm
Height control.....	Hydraulic
Speed control.....	Hydraulic
Auger	
Tube diameter.....	410 mm (16.1 in.)
Diameter (flights included).....	660 mm (26 in.)
Arrangement of auger fingers.....	In-line pattern
Diameter of auger fingers.....	16 mm (0.63 in.)

**EG- Konformitätserklärung nach Maschinenrichtlinie
2006/42/EG**

Bitte sorgfältig aufbewahren, jedoch nicht im Fahrzeug

**EC DECLARATION OF CONFORMITY
According to Machinery Directive 2006/42/EEC**

Please keep safely, not inside the vehicle

Hiermit bestätigt die Hereby declares	Zürn Harvesting GmbH & Co. KG	
in alleiniger Verantwortung dass das landwirtschaftliche Anbaugerät the full responsibility for the agricultural implement	Fabrikmarke Brand	Zürn
	Typ Type	Premium Flow
	Model	618/620/622/625/630/635
genehmigt in approved in	Schoental	
am on	10.03.2009	
durch den by the	Hersteller / manufacturer	
den grundlegenden Sicherheits- und Gesundheitsanforderungen der Richtlinie 2006/42/EG entspricht. to full fill the complete safety and health requirements according to machinery directive 2006/42/EEC.		
Zur sachgerechten Umsetzung der in den EU-Richtlinien genannten Sicherheits- und Gesundheitsanforderungen wurden folgende Normen herangezogen: For proper implementation according to the EU Directives for health and safety requirements, the following standards were used:	DIN EN ISO 4254-1 (06/06)	
	DIN EN 632	
Geschehen zu Done at	Schoental	
am on	12/01/12	
		
	Rolf Zürn, Geschäftsführer, CEO	

Metric Bolt and Screw Torque Values

Bolt or Srew Size	Class 4.8				Class 8.8 or 9.8				Class 10.9				Class 12.9			
	Lubricated ^a		Dry ^b		Lubricated ^a		Dry ^b		Lubricated ^a		Dry ^b		Lubricated ^a		Dry ^b	
	N•m	lb-in	N•m	lb-in	N•m	lb-in	N•m	lb-in	N•m	lb-in	N•m	lb-in	N•m	lb-in	N•m	lb-in
M6	4,7	42	6	53	8,9	79	11,3	100	13	115	16,5	146	15,5	137	19,5	172
									N•m	lb-ft	N•m	lb-ft	N•m	lb-ft	N•m	lb-ft
M8	11,5	102	14,5	128	22	194	27,5	243	32	23,5	40	29,5	37	27,5	47	35
			N•m	lb-ft	N•m	lb-ft	N•m	lb-ft								
M10	23	204	29	21	43	32	55	40	63	46	80	59	75	55	95	70
	N•m	lb-ft														
M12	40	29,5	50	37	75	55	95	70	110	80	140	105	130	95	165	120
M14	63	46	80	59	120	88	150	110	175	130	220	165	205	150	260	190
M16	100	74	125	92	190	140	240	175	275	200	350	255	320	235	400	300
M18	135	100	170	125	265	195	330	245	375	275	475	350	440	325	560	410
M20	190	140	245	180	375	275	475	350	530	390	675	500	625	460	790	580
M22	265	195	330	245	510	375	650	480	725	535	920	680	850	625	1080	800
M24	330	245	425	315	650	80	820	600	920	680	1150	850	1080	800	1350	1000
M27	490	360	625	460	950	700	1200	885	1350	1000	1700	1250	1580	1160	2000	1475
M30	660	490	850	625	1290	950	1630	1200	1850	1350	2300	1700	2140	1580	2700	2000
M33	900	665	1150	850	1750	1300	2200	1625	2500	1850	3150	2325	2900	2150	3700	2730
M36	1150	850	1450	1075	2250	1650	2850	2100	3200	2350	4050	3000	3750	2770	4750	3500

Torque values listed are for general use only, based on the strength of the bolt or screw. DO NOT use these values if a different torque value or tightening procedure is given for a specific application. For stainless steel fasteners or for nuts on U-bolts, see the tightening instructions for the specific application. Tighten plastic insert or crimped steel type lock nuts by turning the nut to the dry torque shown in the chart, unless different instructions are given for the specific application.

Shear bolts are designed to fail under predetermined loads. Always replace shear bolts with identical property class. Replace fasteners with the same or higher property class. If higher property class fasteners are used, tighten these to the strength of the original. Make sure fastener threads are clean and that you properly start thread engagement. When possible, lubricate plain or zinc plated fasteners other than lock nuts, wheel bolts or wheel nuts, unless different instructions are given for the specific application.

a “Lubricated” means coated with a lubricant such as engine oil, fasteners with phosphate and oil coatings, or M20 and larger fasteners with JDM F13C zinc flake coating.

b “Dry” means plain or zinc plated without any lubrication, or M6 to M18 fasteners with JDM F13B zinc flake coating.

Unified Inch Bolt and Screw Torque Values

Bolt or Screw	SAE Grade 1				SAE Grade 2 _a				SAE Grade 5, 5.1 or 5.2				SAE Grade 8 or 8.2			
	Lubricated _b		Dry _c		Lubricated _b		Dry _c		Lubricated _b		Dry _c		Lubricated _b		Dry _c	
Size	N•m	lb-in	N•m	lb-in	N•m	lb-in	N•m	lb-in	N•m	lb-in	N•m	lb-in	N•m	lb-in	N•m	lb-in
¼	3,7	33	4,7	42	6	53	7,5	66	9,5	84	12	106	13,5	120	17	150
													N•m	lb-ft	N•m	lb-ft
5/16	7,7	68	9,8	86	12	106	15,5	137	19,5	172	25	221	28	20,5	35	26
									N•m	lb-ft	N•m	lb-ft				
3/8	13,5	120	17,5	155	22	194	27	240	35	26	44	32,5	49	36	63	46
			N•m	lb-ft	N•m	lb-ft	N•m	lb-ft								
7/16	22	194	28	20,5	35	26	44	32,5	56	41	70	52	80	59	100	74
	N•m	lb-ft														
½	34	25	42	31	53	39	67	49	85	63	110	80	120	88	155	115
9/16	48	35,5	60	45	76	56	95	70	125	92	155	115	175	130	220	165
5/8	67	49	85	63	105	77	135	100	170	125	215	160	240	175	305	225
¾	120	88	150	110	190	140	240	175	300	220	380	280	425	315	540	400
7/8	190	140	240	175	190	140	240	175	490	360	615	455	690	510	870	640
1	285	210	360	265	285	210	360	265	730	540	920	680	1030	760	1300	960
1-1/8	400	300	510	375	400	300	510	375	910	670	1150	850	1450	1075	1850	1350
1-1/4	570	420	725	535	570	420	725	535	1280	945	1630	1200	2050	1500	2600	1920
1-3/8	750	550	950	700	750	550	950	700	1700	1250	2140	1580	2700	2000	3400	2500
1-1/2	990	730	1250	930	990	730	1250	930	2250	1650	2850	2100	3600	2650	4550	3350

Torque values listed are for general use only, based on the strength of the bolt or screw. DO NOT use these values if a different torque value or tightening procedure is given for a specific application. For plastic insert or crimped steel type lock nuts, for stainless steel fasteners, or for nuts on U-bolts, see the tightening instructions for the specific application. Shear bolts are designed to fail under predetermined loads. Always replace shear bolts with identical grade.

Replace fasteners with the same or higher grade. If higher grade fasteners are used, tighten these to the strength of the original. Make sure fastener threads are clean and that you properly start thread engagement. When possible, lubricate plain or zinc plated fasteners other than lock nuts, wheel bolts or wheel nuts, unless different instructions are given for the specific application.

a Grade 2 applies for hex cap screws (not hex bolts) up to 6. in (152 mm) long. **Grade 1** applies for hex cap screws over 6 in. (152 mm) long, and for all other types of bolts and screws of any length.

b "Lubricated" means coated with a lubricant such as engine oil, fasteners with phosphate and oil coatings, or 7/8 in. and larger fasteners with JDM F13C zinc flake coating.

c "Dry" means plain or zinc plated without any lubrication, or 1/4 to 3/4 in. fasteners with JDM F13B zinc flake coating.

Serial Number

Product- Identifications number

The platform serial number is displayed on a plate (A) on the right hand side of the platform. When ordering parts, always quote the platform serial number. This will help your dealer to give you prompt service.

A- Serial Number Plate

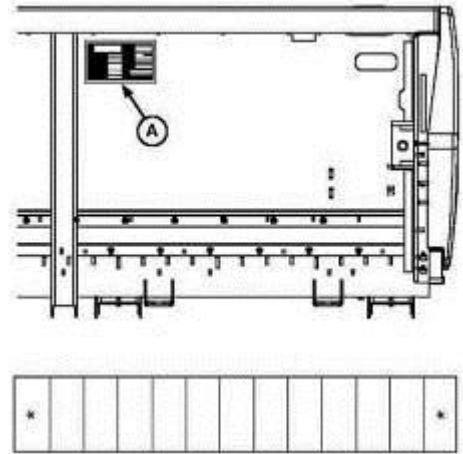

Serial Number Plate

- 1- Model
- 2- Serial Number
- 3- Frame Number (Internal Use only)
- 4- Year of Manufacture
- 5- Weight

ZÜRN Harvesting	Kapellenstraße 1 74214 Westernhausen	MADE IN GERMANY
Model		
Premium Flow 6		1
Serial Number		
		2
Frame Number (Internal Use only)		
		3
		
Year of Manufacture	2013	4
Weight	2780 kg	5
		
MANUFACTURED FOR DEERE & COMPANY, MOLINE, ILLINOIS, USA		

Subject Index

A

Adjust Auger Chain 56
Adjusting Angle of Tilt of the Cutting Platform 52
Adjusting Auger Finger Timing 54
Adjusting Auger Fore/Aft 55
Adjusting Auger Height hydraulically 38
Adjusting Rear Stripper 56
Adjusting Reel Speed Ratio Sensor 70
Adjusting Reel Tine Position 46
Aligning Knife Head and Knife Drive Alignment 76
Attaching and Detaching 26
Auger Anti-Wrap Shields 59
Auger Fingers 81

B

Basic Setting of Reel 46
Beginning of Season Service 94
Bleeding the Reel Lift Cylinders 85

C

Controls 31
Crop Dividers 48

G

Grease 62

I

Identification View 6
Installing Lifting Guards 51

K

Knife Gear Oil 62
Knife Protection Guard 52

L

Lubricant Storage 63
Lubrication Charts 64

M

Metric Bolt and Screw Torque Values 97
Mixing of Lubricants 63

O

Operating the Platform 31

R

Remove and Install Knife Drive Belt and Checking the
Tension 83
Rephrasing Reel Lift Cylinders 85
Replacing Cutterbar Knife 71
Replacing Knife Sections 80

S

Safety Decals 14
Safety Stop for Platform Raising Cylinder 70
Serial Number Plate 99
Service 70
Setting the Safety Stops on the Reel Raising Cylinder
70
Specifications 95
Storage 93

T

Transporting 30

U

Unified Inch Bolt and Screw Torque Values 98

Part Number
Operator's Manual
5ZN51703

October 2012

Deere & Company
European Office - Portfolio Extension R2
John-Deere-Str. 70
D-68163 Mannheim, Germany