

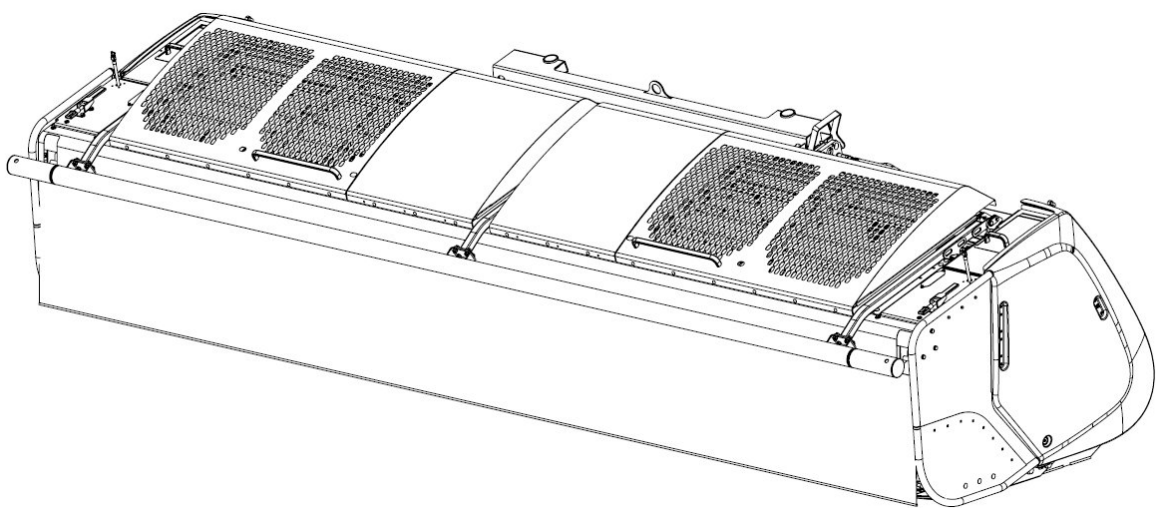

OPERATING MANUAL

Profi Cut 530 · Profi Cut 700



Direct Cut Header
for Forage Harvesters

Masthead

Title: Operating Manual Profi Cut Direct Cut Headers
Manufacturer: Zürn Harvesting GmbH & Co. KG
Schöntal

Applicable to: PC 530 · PC 700

Print number: 62167

2nd issue 2021 (Version B)

Editorial date 02/2021

© Zürn Harvesting GmbH & Co. KG

Author: Martin Stagl

All rights reserved, also applies to the translation.

No part of this operating manual must be reproduced in any form (print, photocopy or any other process) or processed, duplicated or distributed using electronic systems without the written permission of the Zürn Harvesting GmbH & Co. KG, Schöntal.

We reserve the right to make technical amendments.

Printed on paper made from chlorine-free and acid-free bleached pulp.

Foreword

This machine is designed only for the usual application in agricultural work or similar activities. Any other use beyond this is deemed improper use of the machine. The manufacturer accepts no liability whatsoever for damage resulting from improper use; the risk will be borne solely by the user. Proper use also includes complying with the operation, maintenance and service conditions specified by the manufacturer.

Read this operating manual thoroughly to familiarise yourself with the correct operation and maintenance of the machine and to prevent injuries or damage to the machine. Not doing so can result in injuries or machine damage. This operating manual and the safety labels on the machine may also be available in other languages: please enquire at your dealership.

This operating manual is part of the machine and should be handed over to the purchaser if the machine is re-sold.

Dimensions specified in this operating manual are metric. Use only appropriate parts and bolts. Different spanners are required for metric bolts and bolts with imperial (inch) dimensions.

The designations "left" and "right" are with reference to the forward direction of the machine.

Enter the serial number in the first section of the operating manual. Please record all numbers accurately. In case of theft, these numbers can be important for tracing the machine. Your dealer also needs these numbers when you order spare parts. It is a good idea to keep a second record of these numbers in another location.

Your dealer has carried out an inspection of the machine prior to delivery. A further inspection should be carried out by your dealer after the first 20 to 50 hours of operation in order to ensure the best possible performance for the machine.

This machine must only be used, serviced and repaired by persons who are familiar with it and who have been briefed about its hazards. The relevant accident prevention regulations and other generally recognized rules and laws for safety, occupational health and road traffic must also be observed. Unauthorized changes to this cutter bar release the manufacturer from liability for any resulting damage.

Contents

Masthead	2
Foreword	3
Contents	4
Header Description	7
Rating plate	9
Special Equipment	9
Safety Instructions	10
Safety instructions for technical staff and operators	11
Hydraulic system	12
Universal drive shafts	13
Ejection of stones and foreign objects	14
Precautions for use and shunting	15
Precautions for maintenance and repair work	15
Precautions for travelling on public roads	16
Modifications to the header transporter	17
Welding	17
Bolted assemblies	17
Using original parts	18
Waste prevention	18
Safety decals	19
Scope of delivery	22
Forage Harvester Basic Settings	23
Forage harvester basic settings for whole crop silage	23
Fitting to a John Deere SPFH for the first time	24
Set the body width	24
Hitching the header up	25
Locking the header	25
Connecting the connections	25
Connecting the main PTO shaft	25
Setting the header up	26
Header calibration	27
Option quick coupler (John Deere)	27
Fitting to a Claas Jaguar for the first time	28
Check the header drive	28
Attaching the header	29
Locking the header	29
Linking the connections	29
Option switch on clutch	30
Connecting the main PTO shaft (claw coupling)	30
Adjustment of the pendulum frame	31
Adjusting the header	31
Auto Contour cutting height control setting	32
Setting the precompression	32
Fitting to a Fendt Katana for the first time	33

Identification of the correct adapter frame	33
Attaching the header.....	34
Connecting the header	34
Setting the header.....	35
Fitting to a forage harvester for the first time	36
Adjusting the cutting angle.....	36
Cutting height.....	37
Front bar (adjusting bar)	38
Adjustment instructions	39
Auger Paddles	39
Adjusting the paddles on the intake auger	39
Adjusting the auger horizontally.....	40
Auger height adjustment.....	40
Upper adjustable stripper.....	41
Three-speed gearbox.....	42
Additional speed option	42
Quick blade replacement	43
Structure of the quick blade replacement system.....	43
Blades	43
Direction of rotation of the discs (on a cutter bar).....	44
Fittings	44
Removing the blade.....	46
Fitting	47
Disc replacement	49
Removing central discs.....	49
Replacement.....	50
Spring plate replacement.....	52
Chain lubrication	53
Mode of operation	53
Technical data.....	53
Setting delivery volume.....	54
Chain lubrication filter	55
Crop divider	56
Side Knife	57
Attachment of side knives.....	57
Integrated hydraulic drive	60
Switching on and off on-board hydraulics.....	60
Transportation of the header	61
Loading onto the SWW 660 Header Trailer.....	61
Maintenance	62
Side angle gearbox.....	62
Gearbox oil level check:.....	62
Cutter bar	63
Draining the oil.....	63
Maintenance every 50h or as required:	64
Maintenance every 250h or at the end of the season:	64
Position of the lubrication points	65
Position of the oil level inspection plugs	68

Lubricants and oils	69
Drive gearbox oil	69
Grease	69
Chain lubrication	69
Faults and troubleshooting	70
Technical data	71
General terms of guarantee	73
Torques for metric bolts	75
Certificate of Conformity	76
Contact	78
Spare parts order	78

Header Description

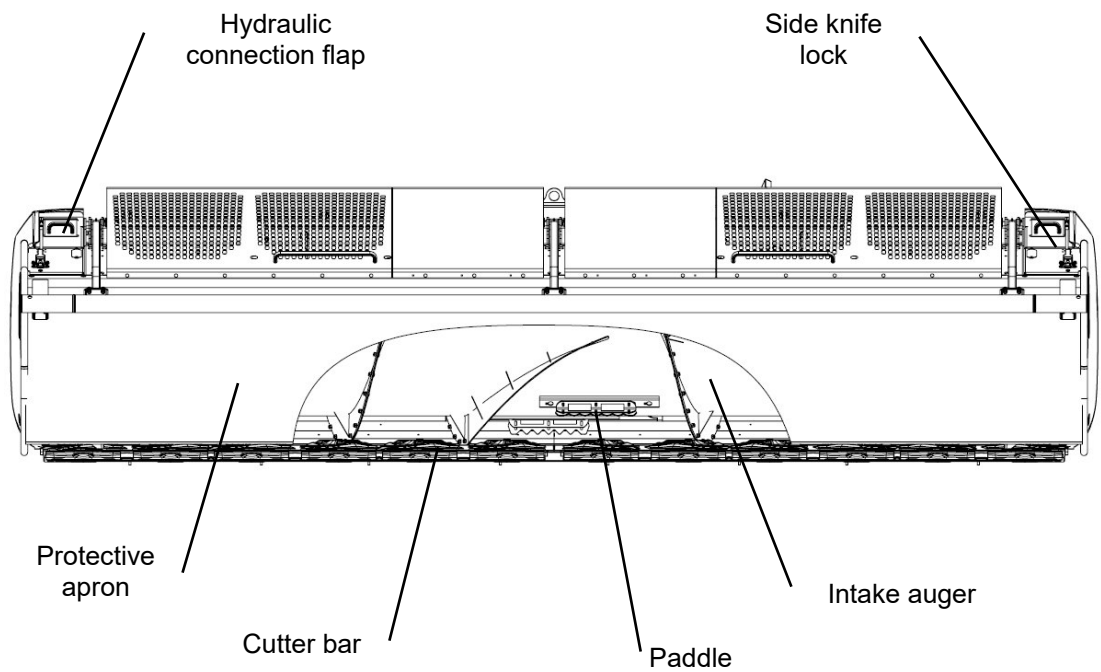
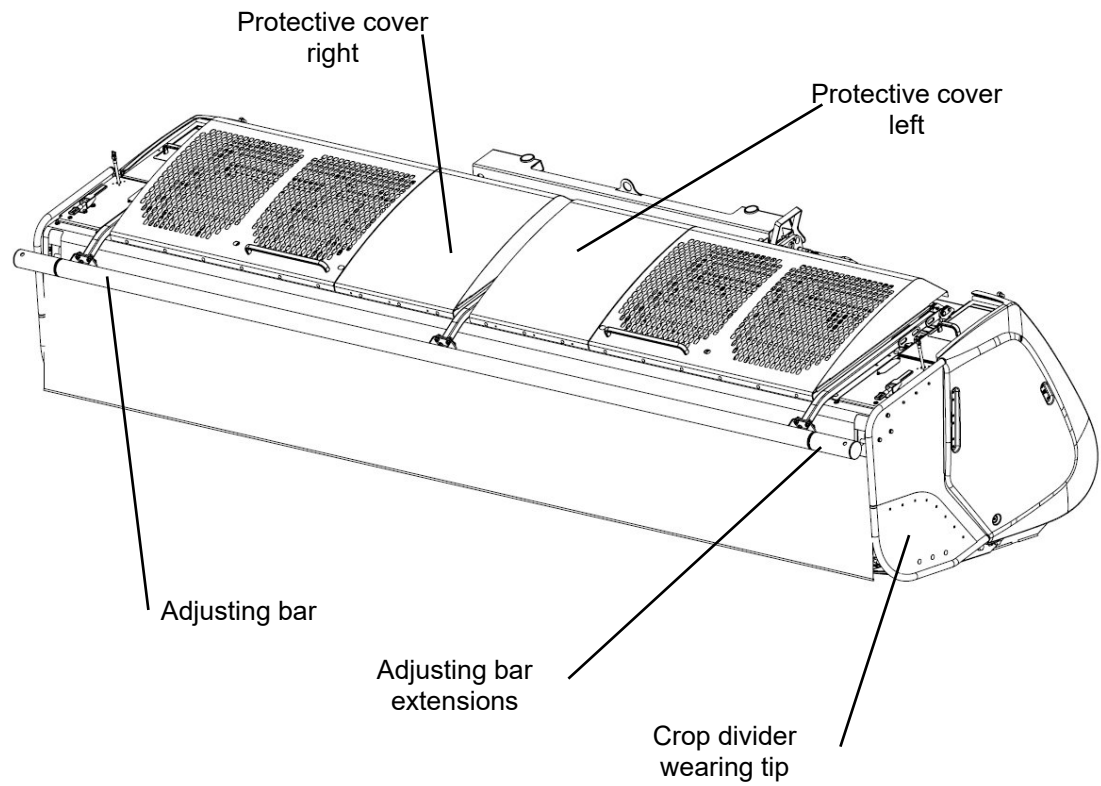

Header Description

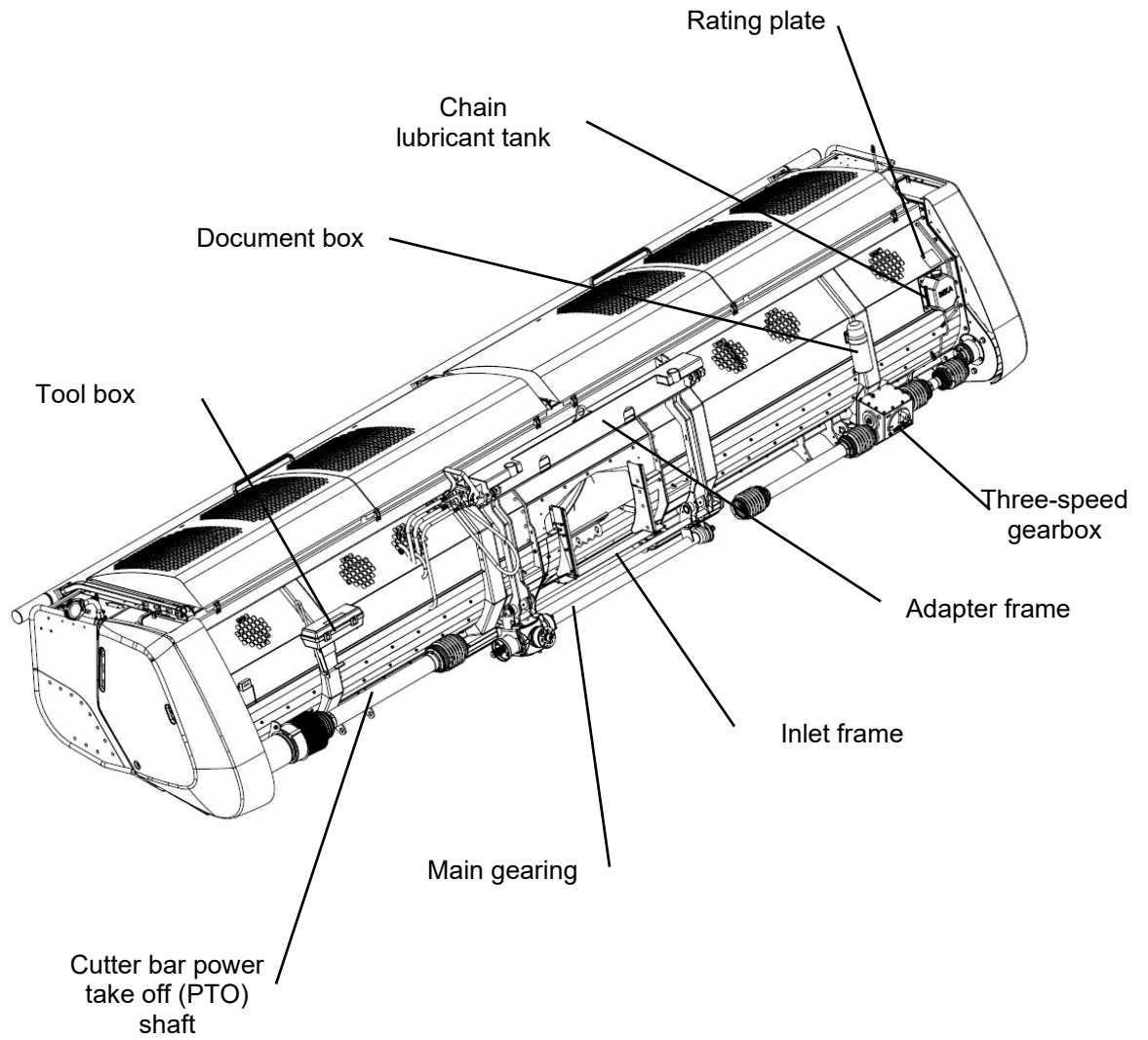

Rating plate

Please make a note of the type designation and serial number of your machine here. This information must be given to the authorised dealer when ordering spare parts or making guarantee enquiries.

Type: _____

Serial number: _____

ZÜRN HARVESTING	
CE	
Typ	_____
Serien-Nr.	_____
Baujahr	_____
Leergewicht	_____ kg
zul. Gesamtgew.	_____ kg
zul. Achslast vo	_____ kg
zul. Achslast hi	_____ kg
Stützlast	_____ kg

Zürn Harvesting
GmbH & Co. KG
Kapellenstraße 1
D-74214 Schöntal-
Westernhausen
Tel. + 497943/91050

Special Equipment

Please enter a cross against the equipment available on your machine:

- Quick-action coupling, main drive.
- (4x) 85 mm high cut runners (3.4")
- Side warning signs (only for the USA)
- Marker lights (only for USA)
- Side knife kit
- Additional hydraulic side knife drive
- Operating hours counter
- Hardox skids
- Chain lubrication
- Roller crop press
- Additional hydraulic mower bar clutch (only Claas Jaguar)
- Hydraulic cutting angle adjustment

Safety Instructions

Explaining the symbols used in this document

This symbol indicates a potentially hazardous situation which, if not avoided, may lead to personal injury.



This symbol indicates special rules or procedures that need to be observed to avoid machine damage.



This symbol indicates special technical instructions.



The illustrations in this manual are used as examples and may differ from the product. All information and data are subject to change by the manufacturer alone without prior notice.

Safety Instructions

Safety instructions for technical staff and operators

Before using the machine, carefully read and observe all safety rules listed in this manual and observe all decals on the machine.

Before starting work, make sure that you are familiar with all mechanisms and controls and their functions. During operation is too late!

Never leave the machine to anyone who has not been trained in using and operating it properly.

Contact your Zürn sales partner if you have problems understanding certain parts of this manual.

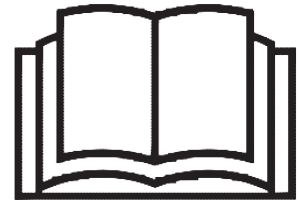

Always apply the handbrake on the header transporter and shut off the engine of the towing vehicle before you work on the transporter. Remove the ignition key and wait until all moving parts have come to a complete stop.

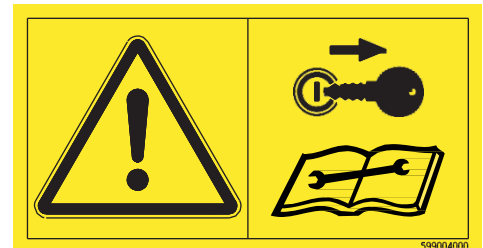

Wear close-fitting clothes! Loose clothing can easily get caught in moving machine parts.

Wear protective gear that suits the work at hand (gloves, footwear, goggles, helmet, ear protectors, etc.).

Any ropes, cables, linkages, etc. of remote-controlled mechanisms must be routed and installed in such a way that they do not cause unintentional machine action leading to accidents and damage. This applies to all transport and working positions.

Before each use verify that nuts and bolts are tight - especially those that attach tools such as blades. Retighten if necessary.

Before you use the machine make sure all safety features and guards are in place, in protective position and operable. Immediately replace any inoperable safety features.



Safety instructions

Hydraulic system

Attention! The hydraulic system is under high pressure. Maximum operating pressure: 200 bar (2900 psi).

Before connecting hydraulic hoses to the hydraulic system of the forage harvester, make certain that it is not pressurised. Before disconnecting hydraulic hoses, depressurise the hydraulic system.

In order to prevent connecting the hydraulic hoses to the wrong connections, colour code the hoses and their respective connections on the tractor without fail. Risk of injury through reverse function because of reversed connections (e.g. raising instead of lowering).

Inspect the hydraulic hoses at regular intervals. Hydraulic hoses must always be replaced after 5 years at the latest. If hydraulic hoses are found to be damaged or worn, they must be replaced immediately. The replacement hydraulic hoses must comply with the technical requirements specified by the manufacturer.

Only use the appropriate resources when looking for leakages. Protect body and hands against pressurised fluids.

Oil escaping under pressure can puncture the skin and cause severe injuries. In the event of injury, seek medical attention immediately. There is a risk of infection.

Before carrying out any work on the hydraulic system, lower the machine to the ground, depressurise the hydraulic system, switch the forage harvester motor OFF, remove the ignition key and wait until all moving parts have come to a complete standstill.



Safety instructions

Universal drive shafts

Only use universal drive shafts that have been provided by or prescribed by the manufacturer.

The protective tube and protective cone on the PTO shaft and all PTO shaft protective devices on the header must be in place and in good condition.

Worn or damaged protective parts must be renewed immediately. Defective protective parts or an unprotected universal drive shaft can cause severe or even fatal injuries.

Always wear close-fitting clothing to prevent being caught up in a rotating universal drive shaft.

Before connecting or disconnecting a universal drive shaft and before any intervention in the header, uncouple the main drive, switch the forage harvester motor OFF, remove the ignition key and wait until all moving parts have come to a complete standstill.

When using universal drive shafts with and overload or free-wheel clutch, always connect the overload or free-wheel clutch to the machine.

Always make certain that the universal drive shaft is connected and latched in position correctly.

Before switching the PTO shaft ON, make certain that the speed and direction of rotation of the attachment conform with the speed and direction of rotation of the machine specified by the manufacturer.

Before switching the PTO shaft ON, make certain that there are no persons or animals within the machine's danger zone. Never switch the PTO shaft ON or engage it if the forage harvester's motor is switched ON.



Safety instructions

Ejection of stones and foreign objects

To increase the safety of the driver, only use the header with an enclosed driver's cab. The area to be mown must be free of foreign objects. Stony or rocky ground should not be mowed. If this is unavoidable, additional safety measures must be taken, e.g.:

- Fit Macrolon panels to the floor, sides and rear of the driver's cab or fit finely meshed grilles to the outside.
- Adjust the cutting height such that any contact with stones or rocks is excluded.

Never switch the header ON when persons are standing in the vicinity of the machine.

Foreign objects can be ejected from the machine, even if the machine is in proper use. Stones and other foreign objects that are caught up by rotating parts can be thrown over great distances. Exclude all persons from the danger zone.

The guard plates and protective aprons lessen the risk of stones and foreign objects being ejected. It must therefore be ascertained that all protective devices are fitted and in perfect condition when the header is in use.

Check the state of the protective aprons at regular intervals. Worn, damaged or missing parts must be replaced immediately.



Safety Instructions

Precautions for use and shunting

Before changing over from transport to working position and vice versa, ensure that no persons are within the manoeuvring zone of the machine.

Precautions for maintenance and repair work

Before carrying out any work or intervention on the header transporter, shut off the engine on the towing vehicle, remove the ignition key, wait until all moving parts have come to a complete standstill and apply the parking brake. Depressurise the hydraulic system.

Prop up and secure any machine parts that are raised for maintenance or repair.

Disconnect all electric lines from the towing vehicle before working on the electric system or before welding on the transporter.

Repairs on parts under strain or pressure (springs, accumulators, etc.) must be carried out solely by specialist staff who have the necessary qualification and special tools.

Wear protective gear that suits the work at hand (gloves, footwear, goggles, helmet, ear protectors, etc.).

Do not weld, solder or use flame cutters near pressurised liquids or highly flammable products.

Only use original spare parts to ensure your personal safety and correct functioning of the header transporter.

We strongly recommend to have the machine and its parts and fastening elements checked by your authorised Zürn Harvesting sales partner after each season.



Safety Instructions

Precautions for travelling on public roads

Dimensions

The combination must comply with local requirements relating to maximum dimensions for travel on public roads. In case of doubt, seek information beforehand from the relevant authorities.

If the combination exceeds the maximum dimensions and yet has to be transported on public roads, contact the local authorities to obtain a special permit before you travel on public roads.

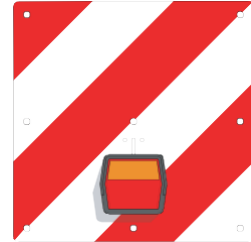

Transport position

Before travelling on public roads, place and secure the machine on a suitable transporter, following the instructions in this manual.

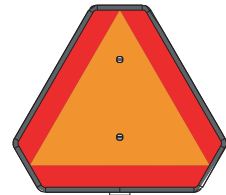

Lights and warning devices

Before travelling on public roads, ensure that all required lights and warning panels are in place.

Check these devices for proper functioning and visibility. Replace any missing or damaged parts immediately.

Maximum speed

Always comply with the current regulations regarding speed limits on public roads.



When travelling on public roads, always comply with the relevant regulations.

Before travelling on public roads and before each use check the header transporter and the towing vehicle for road safety and operational safety!



Safety Instructions

Modifications to the header transporter

Any modifications to the transporter and its optional features must be approved in writing by the manufacturer. The warranty and product liability will be voided, if such modifications are carried out without the written approval of the manufacturer.

The manufacturer's liability refers to the original condition in which the vehicle is delivered to the country of destination as contractually agreed by the manufacturer.

Any unauthorised modifications to this transporter render any manufacturer liability for any consequential damage null and void.

Welding

Ensure that any type of welding is carried out by qualified and certified welders. Welding must not affect the warranted properties of the steel structure. This applies in particular to structural parts and to the components that support the load. For this reason, any type of welding on the chassis and axles must be approved in writing by the manufacturer. In case of non-compliance, the manufacturer shall consider the weldment as an unauthorised modification to the transporter.

Bolted assemblies

Observe the property class when fastening and replacing bolts and nuts (see the table in this manual and the parts list).

After assembling the transporter, tighten all bolts to the proper torque.

For special torques read the assembly instructions or ask the manufacturer.

For any torques of regular bolts refer to the table.

Self-clinching bolts and nuts must be replaced by new ones after they have been removed during a repair.

This is necessary as nuts with a self-clinching fastener lose their holding power with each reuse.

Safety Instructions

Using original parts

Only use original parts sourced from the manufacturer. This is mandatory. Using third-party parts voids the manufacturer warranty including for consequential damage resulting from this.

Waste prevention

Never pour environmentally hazardous products (oils, greases, filters, etc.) into a sink or empty them onto the ground or in other spaces. Never burn or throw away used tyres. Have waste disposed of by specialised disposal companies.

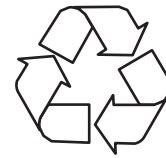

Safety Instructions

Safety decals

Safety decals are placed in various locations on the machine. Always follow these instructions! The decals alert operators to potential hazards and provide rules of practice to cut out any risk of an accident.

Keep the safety decals clean and legible and replace them immediately when damaged, worn or lost.

Operating instructions

The operating instructions contain all the necessary information for the safe use of the machine. To avoid the risk of accidents, read the operating instructions carefully and follow all instructions.



Working on and intervening in the header

Before carrying out any type of work on or intervention in the header, disengage the clutch in the driveline, shut off the engine, remove the ignition key, wait until all moving parts have come to a complete standstill and apply the parking brake.



Parking the transporter

Secure the transporter with a wheel chock before removing it from the towing vehicle or parking it.



Safety Instructions

Placing the header on the transporter

When placing the header on the transporter, keep clear of the danger zone between the header and the transporter.



The header is lifted

Keep clear of the header swing area when placing it on the transporter.

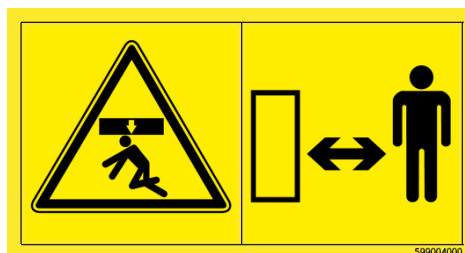

Risk of crushing

Keep clear of the drawbar unit and all steering elements (e.g. turntables, steering rods) while operating the machine. Risk of being crushed at a full lock turn.

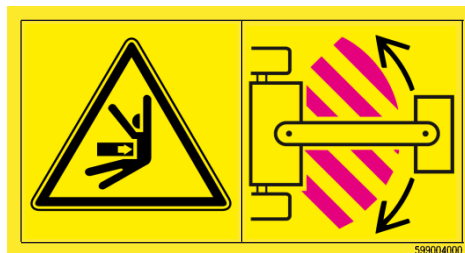

Retighten the wheel bolts

Retighten the nuts after the first journey.

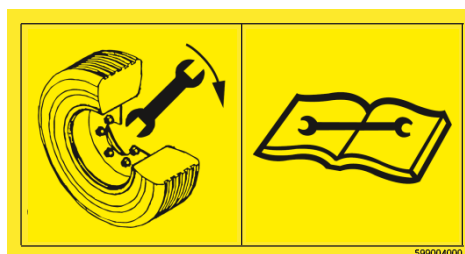

Sicherheitshinweise

Ejection and foreign objects

Stones and other foreign objects can be thrown out over long distances. The protective devices must always be in place and in a perfect state. Always keep a safe distance from the machine.



Do not open guards

Do not open or remove guards while the engine is running.



Do not open guards

Do not open or remove protective devices during operation.



Rotating Auger

Never reach into the rotating auger.

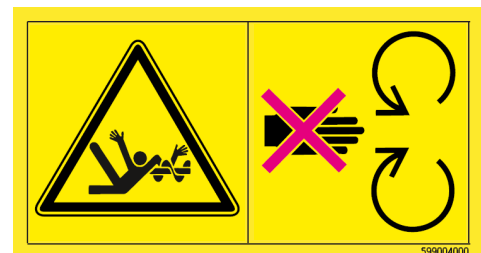

Scope of delivery

The scope of delivery includes a special tool for replacing cutter blades which is stored in the holder on the tool box.

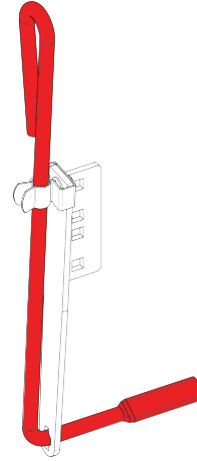

A 13 mm T-handled wrench is stored in the tool box. This is required to open the protective covers.



An additional cover is provided to alter the shaft width.

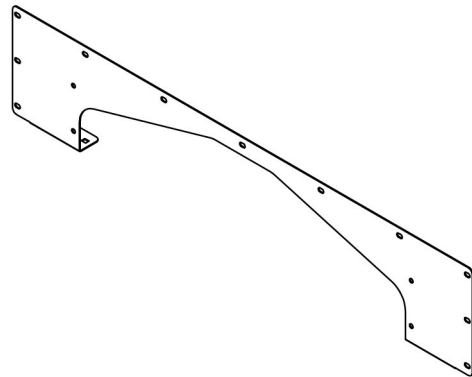

An Operating Manual and a spare parts list are stowed in the document box when the machine is delivered.

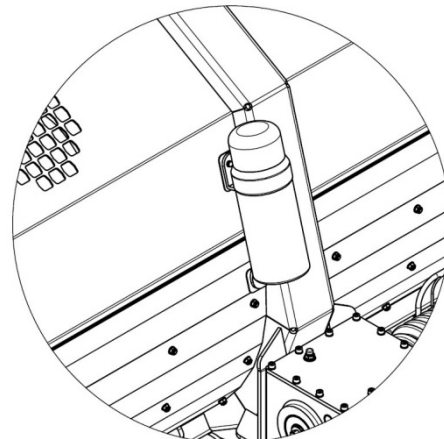

Forage Harvester Basic Settings

Forage harvester basic settings for whole crop silage

The following settings should be preferably used. These are not binding and can be adapted to suit the specific environmental conditions.



- Fit the maize shear bar
- Fit the stepped blade for maize
- Fit the grain plates under the feed rollers
- The grain processor can be optionally swivelled in (depending upon harvesting conditions)
- Adjust the spring tension on the feed roller if necessary (loosen)
- Full set of blades for optimum feed speed

The basic settings and how they can be changed can be found in the respective John Deere Forage Harvester Operating Manual.

In addition to this the driver training courses and setting instructions given by the dealer's service personnel are also helpful.

Fitting to a John Deere SPFH for the first time

Set the body width

Before the direct header is fitted for the first time, the correct body width must be set. The cover plate provided may need to be fitted, depending upon the shaft width required.

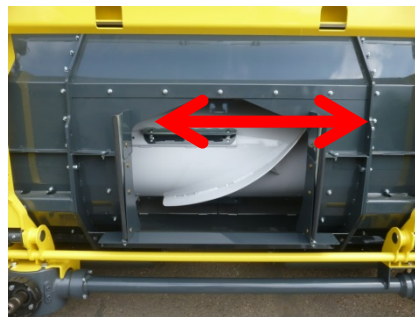

Standard body width: 660 mm

Series 8100-8500 up to MY2018
Series 8000 from MY2019 (8100-8500)

Cover plate: 62013



Wide body setting: 830 mm

Series 8600-8800 up to MY2018
Series 9700-9900 from MY2019

Cover plate: 62012



The state of the header when it leaves the factory is as follows:

- Profi Cut 530 Standard body width 660 mm
 - Profi Cut 700 Wide body width 830 mm
-

Fitting to a John Deere SPFH for the first time

Hitching the header up

Unload the header from the transportation vehicle with the pendulum frame. Do this by approaching the header with the pendulum plate lowered. When the hooks are visible in the receptacles, raise the header slowly.

Locking the header

Refer to the corresponding chapter in the forage harvester's Operating Manual

Connecting the connections

Connecting the hydraulic lines and the electrical connections by means of the multi-connector



Connecting the main PTO shaft

Refer to the corresponding chapter in the forage harvester's Operating Manual

Fitting to a John Deere SPFH for the first time

Setting the header up

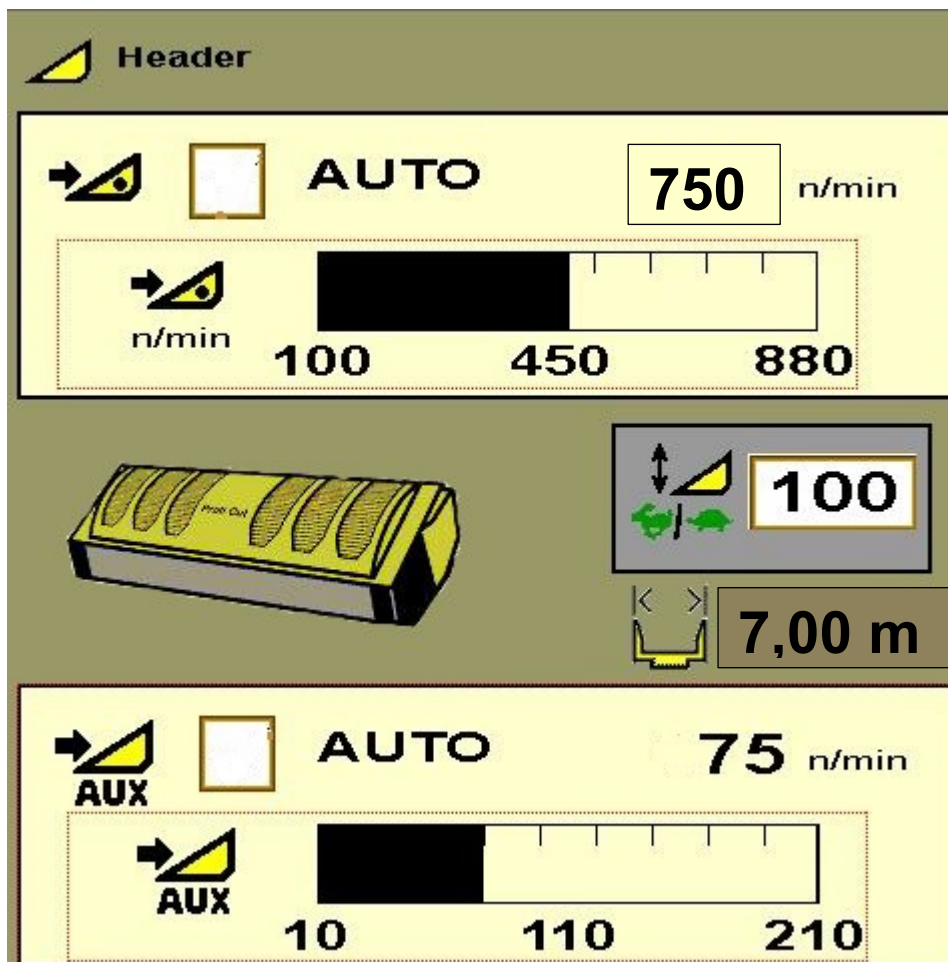

The header is automatically detected by the John Deere 8000 series forage harvesters. Because of this, certain functions of the header will be automatically displayed. Certain basic settings will be made by connecting the multi-connector. These should be checked and adjusted if necessary.

Once the header has been automatically detected, the following information will be shown on the display:

- Image of the header
- Speed of the header (nominal speed 750 revs/min)
- Speed of the auxiliary drive (if available, is required to operate the side cutters)
- Lifting speed of the header (value in % of the range, goes from 0-100%)
- Header width in mm
 - Profi Cut 530 5.30 m
 - Profi Cut 700 7.00 m

Fitting to a John Deere SPFH for the first time

Header calibration

- Header lift range
- Header

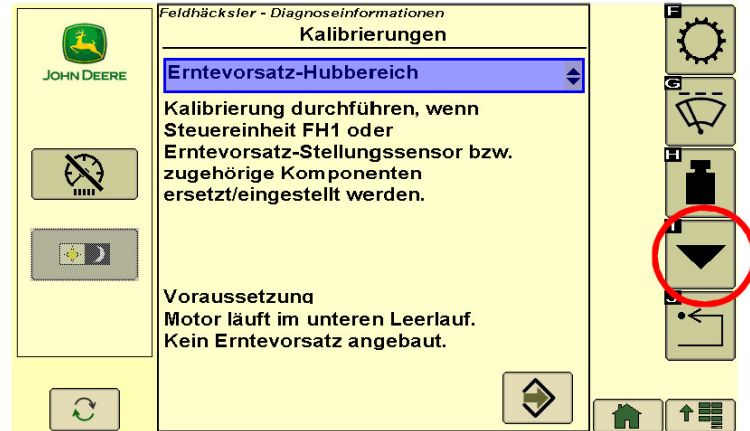

The basic settings and how to change them can be found in the relevant operating manual for the John Deere forage harvester.

Furthermore, the driver training courses and setting instructions of the service personnel of the sales partner are also helpful.

Option quick coupler (John Deere)

The main gearbox can be connected to the forage harvester by means of a quick coupler. This is available as an option.



Only the quick coupler offered by Zürn Harvesting fits to the Profi Cut header.

Reference: 61798

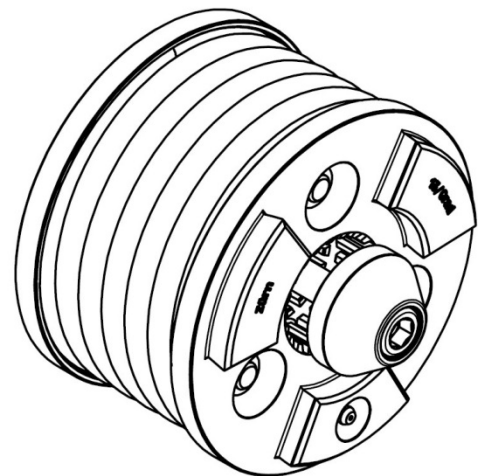

Fitting to a Claas Jaguar for the first time

Check the header drive

Power-split header drive

- Driving a direct cut header (Profi Cut) is possible

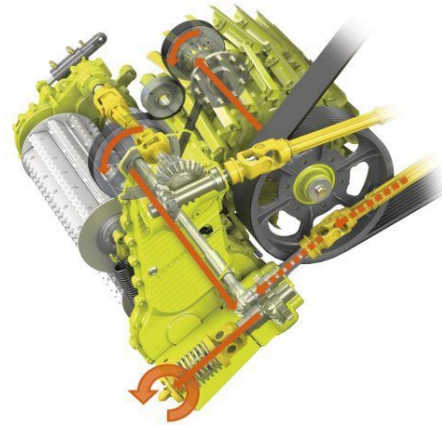

Hydraulic header drive

- Driving a direct cut header (Profi Cut) is **not** possible

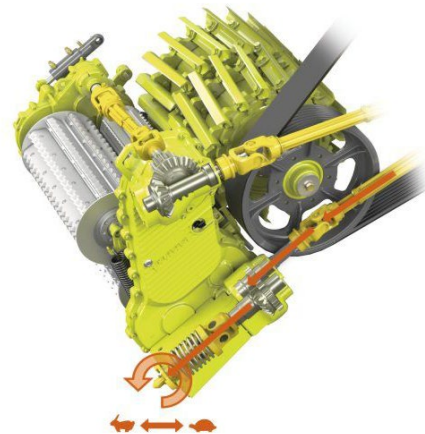

Mechanic header drive

- Driving a direct cut header (Profi Cut) is possible

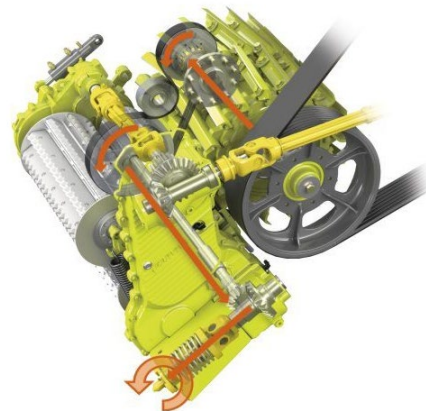

Fitting to a Claas Jaguar for the first time

Attaching the header

Use the pendulum frame to pick up the cutting unit from the transport trailer. To do this, slowly approach the cutting unit with the pendulum blade lowered until the attachment is touched by the pick-up blade, then slowly lift the attachment.



Locking the header

The two locking hooks can be adjusted with the fork heads of the actuation. The counter linkages must be adjusted to the forage harvester.

See the corresponding chapter of the forage harvester operating manual (BA 7.12.2).

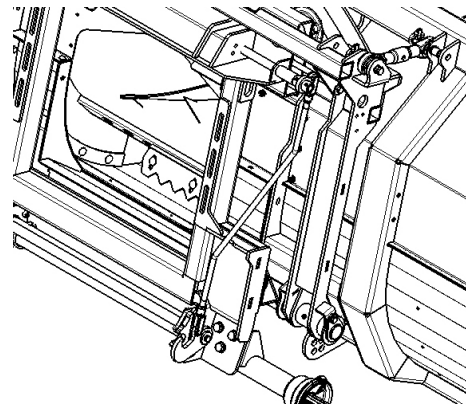

Linking the connections

Connect the hydraulic lines and the electrical connections using the couplers.

As standard, the two flat sealing couplers for the crop deflector and the 13-pin plug for the electrical interface must be connected.



Fitting to a Claas Jaguar for the first time

Option switch on clutch

If an additional switch-on coupling is installed, also connect the coupler for the switch on clutch (yellow) in addition to the hydraulic connections for the crop deflector.

The switch on clutch reduces the starting torque of the attachment drive. A smooth start-up of the attachment is ensured.

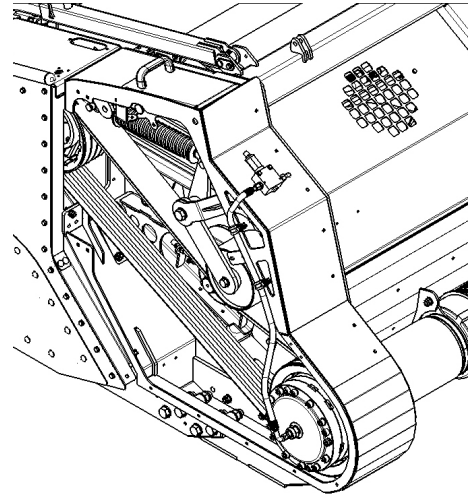

Connecting the main PTO shaft (claw coupling)

During initial installation, the claw of the PTO shaft connection must be adjusted.

See corresponding chapter of the operating manual of the forage harvester (BA 7.12.1 and BA 7.13.1).



Fitting to a Claas Jaguar for the first time

Adjustment of the pendulum frame

Level the cutterbar horizontally to the ground. To do this, adjust the two springs in the pendulum frame.



Tighten and loosen adjustment screws on both sides of the pendulum frame as required. This increases or decreases the spring tension.

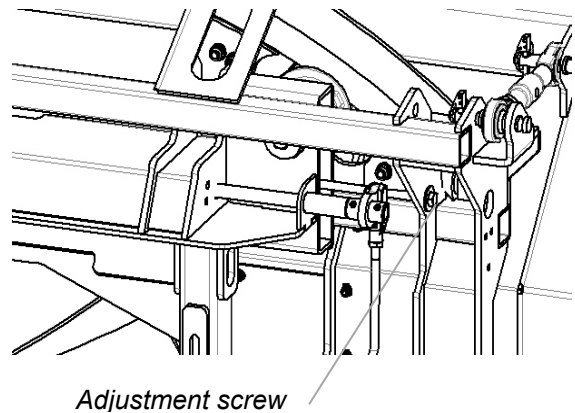

Adjusting the header

Set the attachment selection to "Direct Disc".

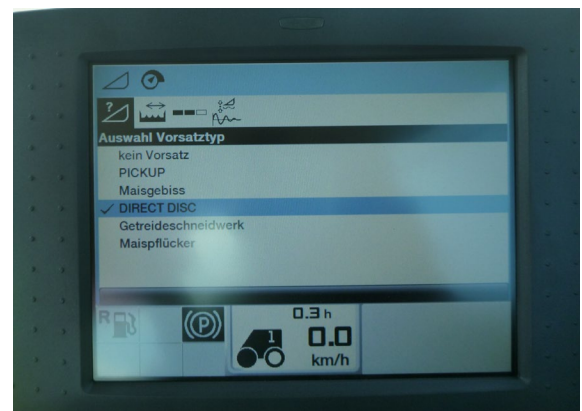

Fitting to a Claas Jaguar for the first time

Auto Contour cutting height control setting

Set the auto contour control to the value 33.

- If the support pressure is too high, increase it by 3 step by step.
- If the support pressure is too low, reduce it by 3 step by step.

See corresponding chapter of the operating manual of the forage harvester (BA 7.16.4 and BA 7.16.6).

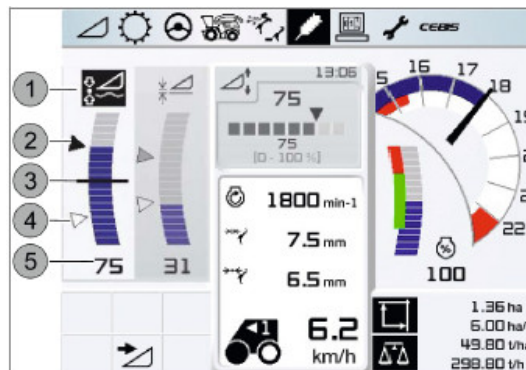

Setting the precompression

See corresponding chapter of the operating manual of the forage harvester (BA 7.15.6)

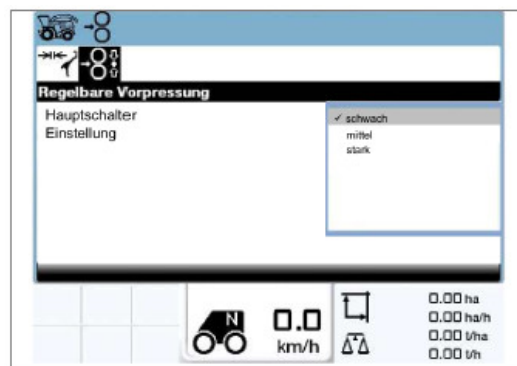

Fitting to a Fendt Katana for the first time

Identification of the correct adapter frame

Consider different distances of the locking claws (depending on type).

Fendt Katana type 650/652/653

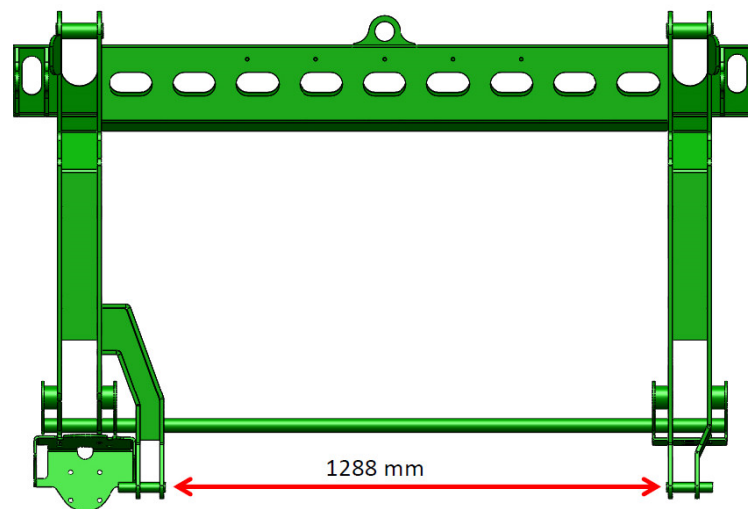

Fendt Katana type 658

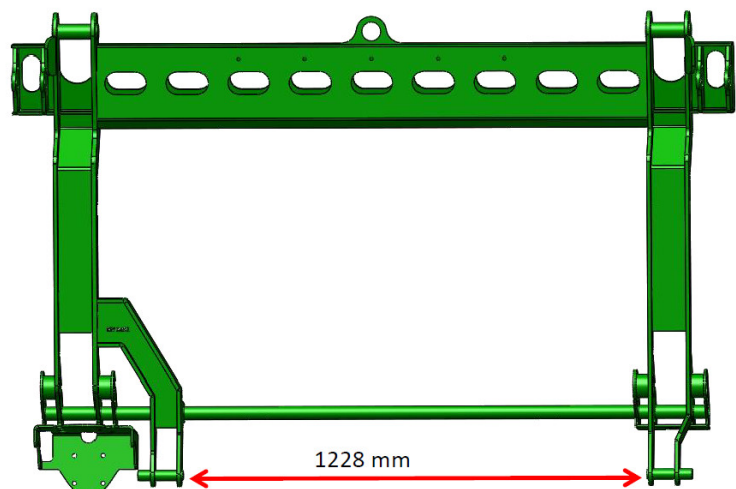

Fitting to a Fendt Katana for the first time

Attaching the header

Slowly approach the attachment with the forage harvester until the pins on the right and left of the attachment are above the pick-up claws. Raise the lifting unit until the lower pick-up claws engage in the pins. Then close the red locking lever and secure it with a split pin.



Connecting the header

Couple the hydraulic lines at the right points following the labeling.

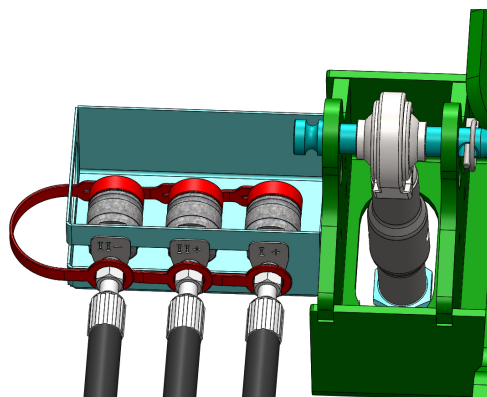
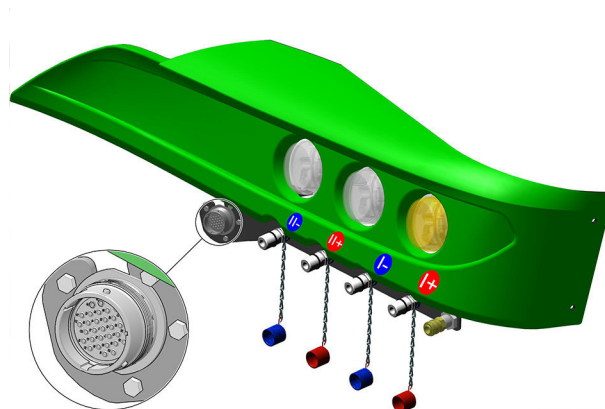

Fitting to a Fendt Katana for the first time

Setting the header

The attachment ID for the Profi Cut is: 1002 and should be present as a sticker on the cutting unit.

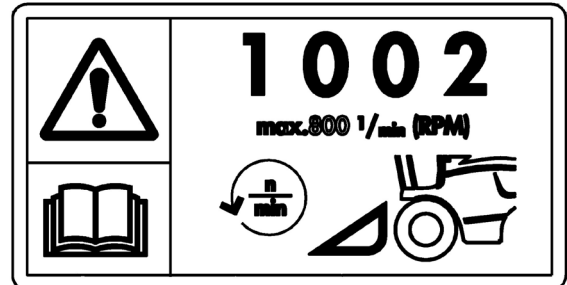

Open the page of the attachment in the main display.

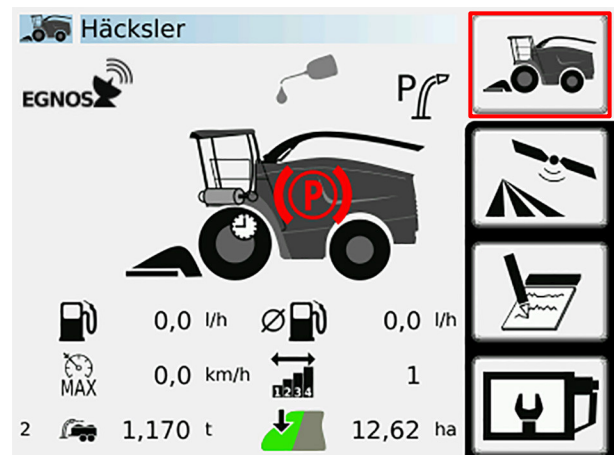

Select attachment selection via the external operating element or the touch screen. Press the softkey Plus to open the popup for selecting the attachment. Select the attachment and make the settings. The page with the selected attachment appears. The lifting gear must then be calibrated

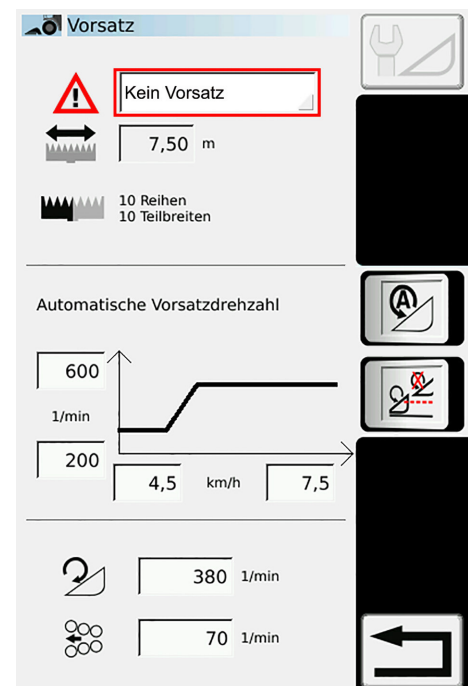

Fitting to a forage harvester for the first time

Adjusting the cutting angle

The header is equipped with 4 main sensing runners. These must first be in contact with the ground. This evenly distributes the main load over the sensing runners.

The line (A) represents the reference surface (ground).

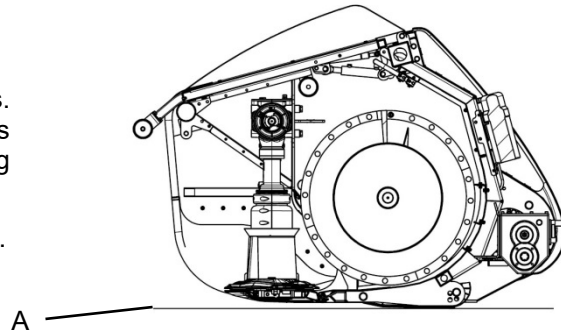

The four sensing runners can be adjusted to four different positions. To enable this, the rear hexagon headed bolts (M20x45) must be completely removed. The two front hexagon headed bolts (M20x45) must be loosened. When this has been done, the runner can be turned to the desired position and fixed in position by tightening the hexagon headed bolts.

Tightening torque: 20 daNm (145 lbf ft)



The angle of the header can then be adjusted with the aid of the two top spindles. Both spindles must be evenly adjusted.



The adjustment can be accomplished with the aid of an electronic spirit level.



Fitting to a forage harvester for the first time

Cutting height

0° inclination to the ground

The maximum cutting height $L1 = 80 \text{ mm}$ (3.1") is achieved if the cutter discs are parallel to the ground.

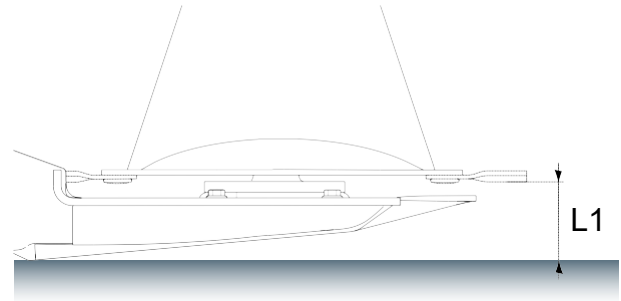

4° inclination to the ground

The minimum cutting height $L2 = 50 \text{ mm}$ (1.9") is achieved when the cutter bar is inclined by 4° to the front.

Too low a cutting height means increased wear to the cutter discs and cutter blades. In addition to this, more dirt will be picked up with the harvest.

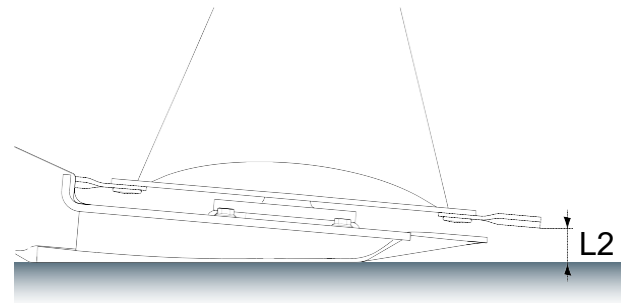

When the cutting angle of the header has been adjusted, the seal parallel to the adapter frame must be adjusted. This must be done at both sides of the adapter frame. The angle of the seal holder can be altered by loosening the 4 mushroom headed bolts.



Fitting to a forage harvester for the first time

Front bar (adjusting bar)

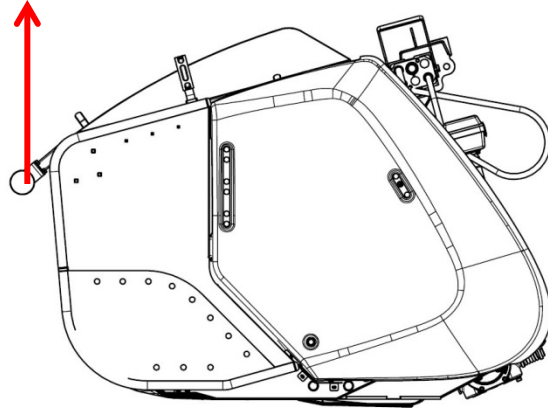

The front bar can be adjusted to the height of the harvest by the single-acting hydraulic function of the forage harvester. The optimum height is achieved when the harvest is fed evenly to the intake auger.

Single acting hydraulic cylinders

Standard feature on ProfiCut for Fendt Katana and John Deere.

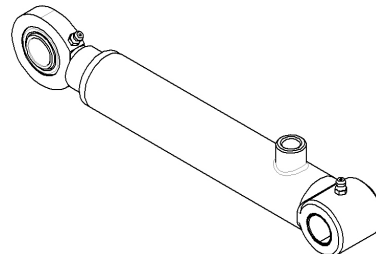

Double acting hydraulic cylinder with locking block

Standard feature on ProfiCut for Claas Jaguar.

Optionally available for ProfiCut for John Deere and Fendt

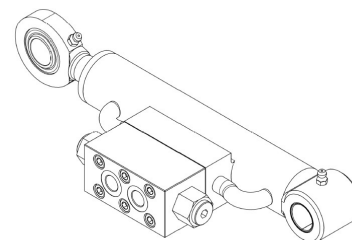

Adjustment instructions

Auger Paddles

Four paddle brackets and paddles are fitted to the intake screw. These can be fitted at different widths, heights and aggressivity.

The paddles can be shifted on their brackets by means of the mushroom headed bolts (35). To do this, remove the bolts, align the paddles to different holes and replace the bolts.

The aggressivity can be set by turning the paddle (13).

Important note:

The paddles are fitted for low yields of barley.

The paddles and brackets must be removed for high crops and yields.

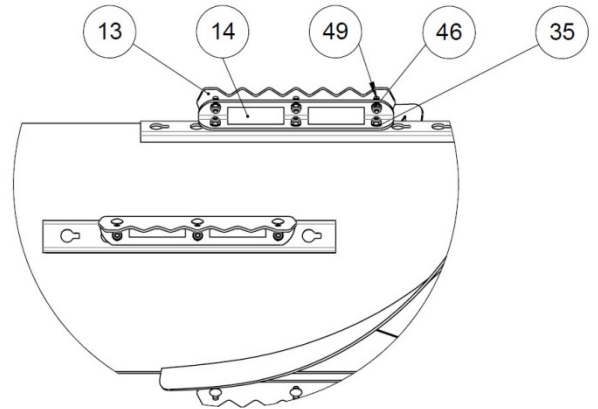

Adjusting the paddles on the intake auger

The paddles on the intake auger can be moved and turned. There are two positions. Aggressive and non-aggressive.

Figure 1 shows the "aggressive" position.



Figure 2 shows the "non-aggressive" position.



Adjustment instructions

Adjusting the auger horizontally

The auger can be shifted horizontally in both directions. To do this, the four M12x45 hexagon headed bolts must be loosened. The position of the auger can then be adjusted by means of the eye bolt. When adjusting the horizontal position, make sure that the auger is adjusted evenly at both ends. Check this setting by measuring the length of the eye bolts. When making this adjustment, make sure that the auger does not make contact with the stripper.

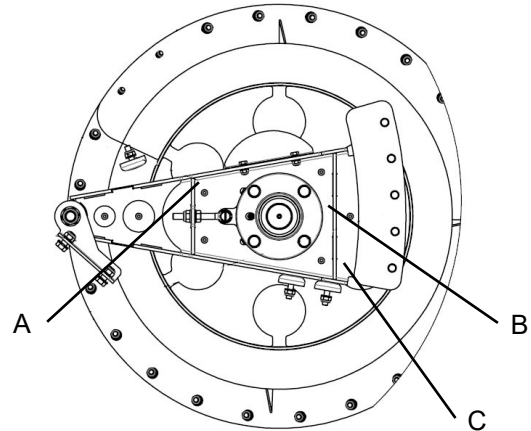

To do this, loosen the bearing securing bolts (B). Then bring the eye bolt (B) horizontally to the desired position. When this has been adjusted, tighten the securing bolts (B) once again.

Tightening torque: 95 Nm (70 lbfft)



Auger height adjustment

Loosen the locking nuts on both rubber dampers (C). The height of the auger can then be adjusted. This is only necessary, if the auger makes contact with the ground stripper. Once the height has been adjusted, the setting of the stripper must be checked.

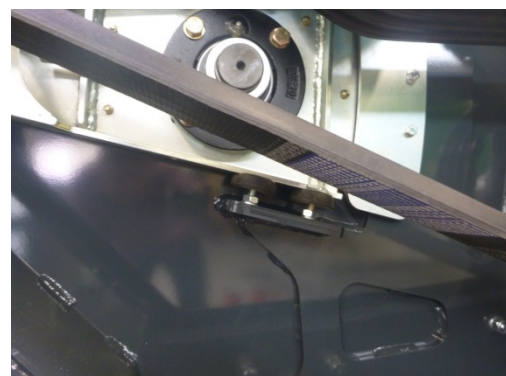

Adjustment instructions

Upper adjustable stripper

By loosening the securing bolts (M8x20), the upper stripper can be adapted to suit the harvesting conditions by adjusting it horizontal to the direction of travel.

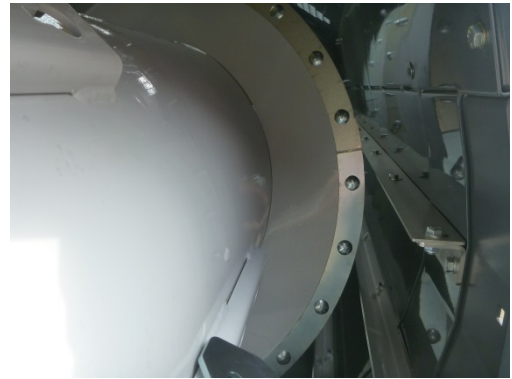

When taking this adjustment measure, make sure that the auger in the upper position does not make contact with the stripper.

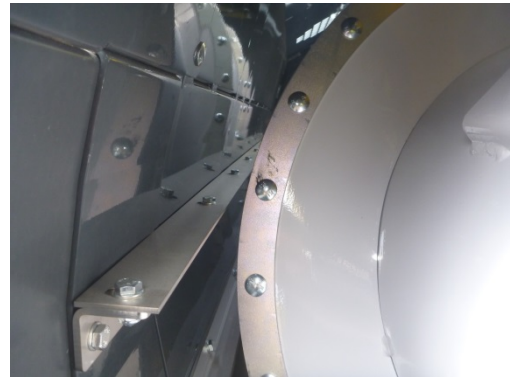

Adjustment instructions

Three-speed gearbox

For setting the optimum speed of the auger, a three-speed gearbox is fitted to the rear of the header. The speed of the auger can be adapted to suit the cut length by means of this. Pull the gear lever gently, move it to the desired position and allow release the lever to allow it to engage.

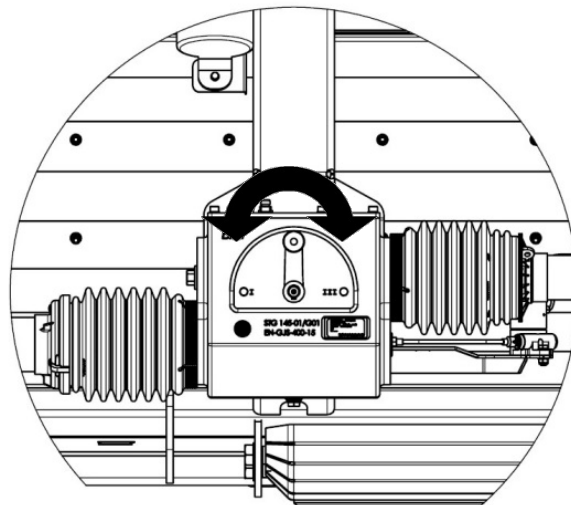

Intake auger speeds:

I Gear	55 revs/min
II Gear	85 revs/min
III Gear	128 revs/min

Additional speed option

To further increase the speed of the auger, the drive sprocket can be replaced as an option. A Z=12 is installed as standard.

Standard: Z=12
Item number: 60746

Option: Z=15
Item number: 60745

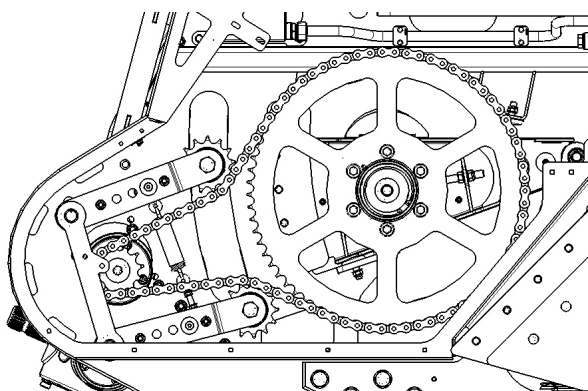

Quick blade replacement

Structure of the quick blade replacement system

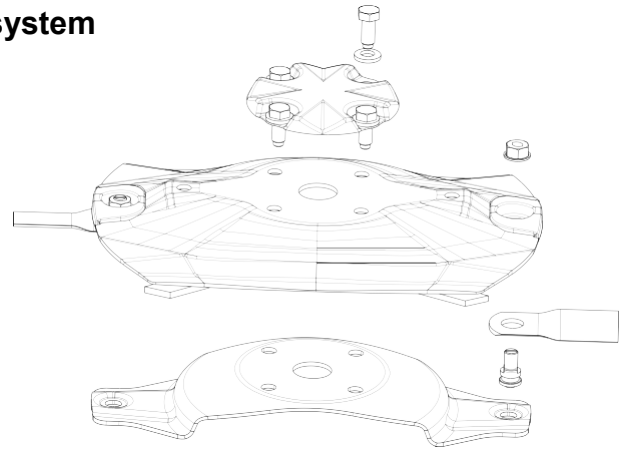

Blades

The blades must always be inspected before using the machine. This serves to ensure the mowing quality. In uneven terrain the blades can suffer cracks or bend.

The length of a blade must be more than 80 mm (3.15").
The width B of the blade, measured from A=10 mm (0.39") of the disc, must be at least 34 mm (1.34").

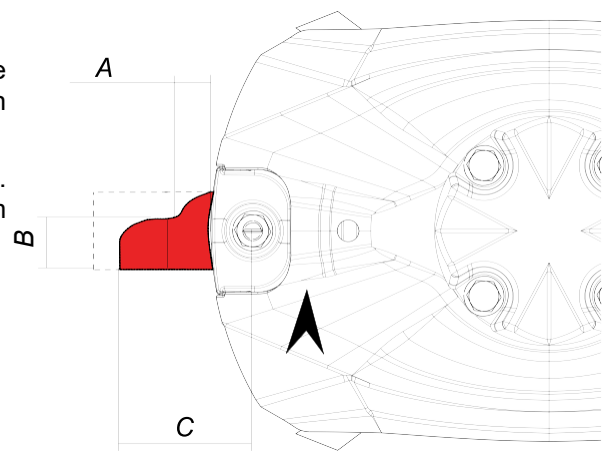

The fastening hole must not be flared to a size L of more than 22 mm (0.87").

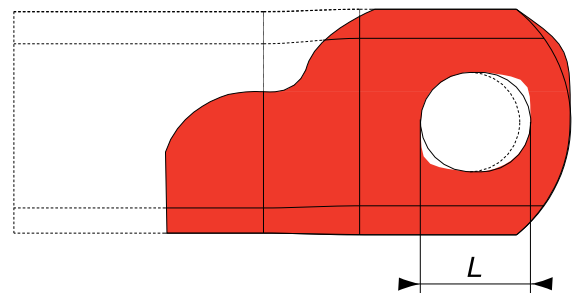

Quick blade replacement

Direction of rotation of the discs (on a cutter bar)

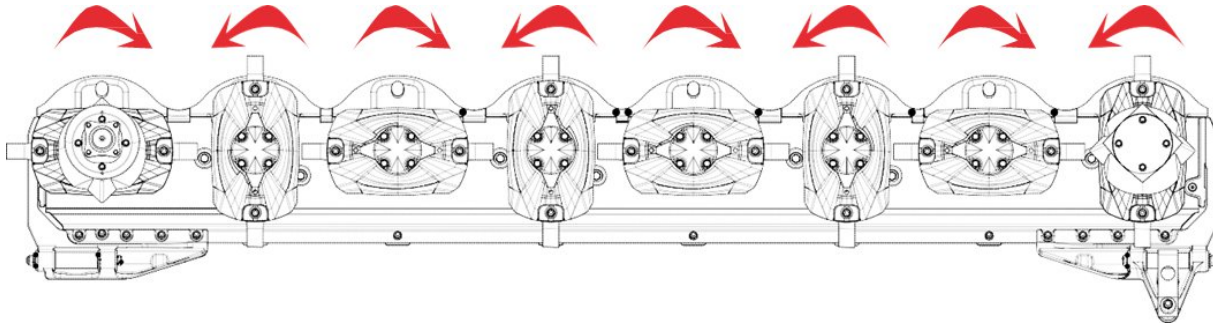

Fittings

Inspect the fittings:

- After hitting an obstacle
- When blades are replaced
- At the start of every season

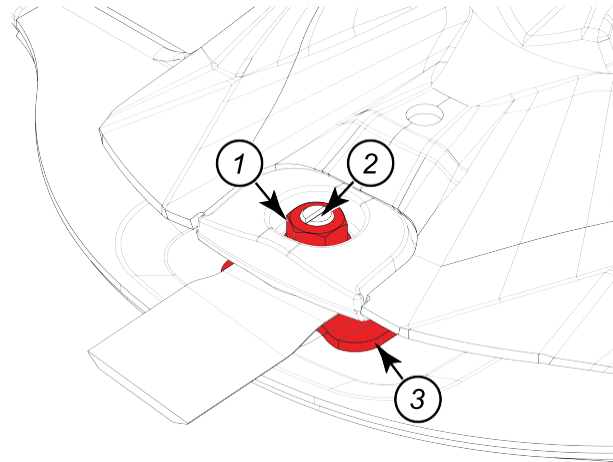

The fittings must be replaced if:

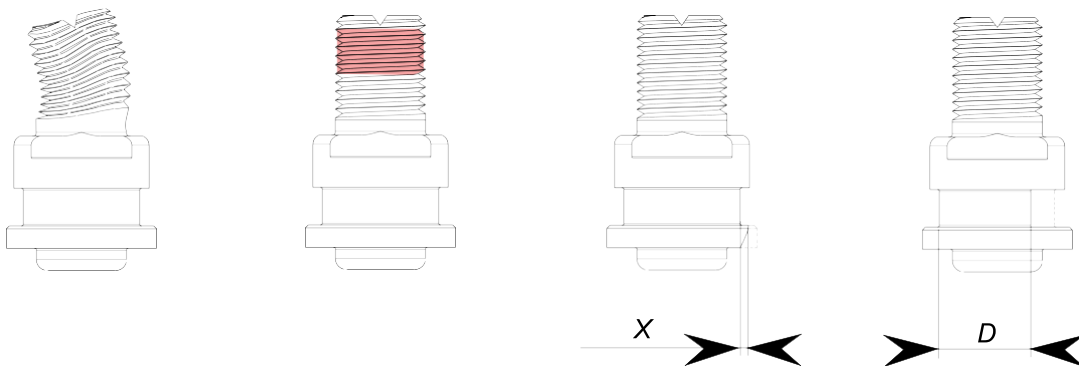

- Visibly deformed.
- Locking fluid (Loctite) is not applied or is ineffective
- There is only $X = 2$ mm of material available between the head of the bolt and the shaft.
- The shaft diameter D of the bolt is less than 11 mm.

Quick blade replacement

Remove harvest residue from between the blade and the bolt by hitting it lightly with a wooden mallet.

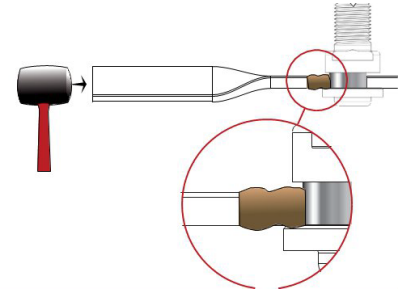

The radial play between a worn bolt and a new blade must not exceed $d=10$ mm (0.4")

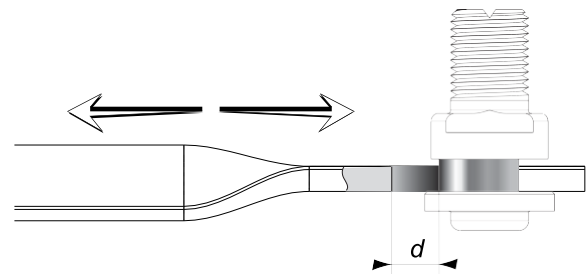

The fastening bolt must be replaced if the degree of wear of the nut is $a=5$ mm (0.2").

Check the state of the fittings and tightening torque of the blade fastening nut at regular intervals:

Tightening torque: 12 daNm (89 lbf ft)

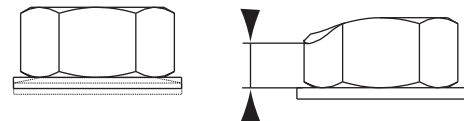

The spring plate must be replaced in the following cases:

- It is visibly deformed
- The spring plate is heavily worn

The width B of the spring plate, measured at position $A=20$ mm (0.8") must be greater than 60 mm (2.4").

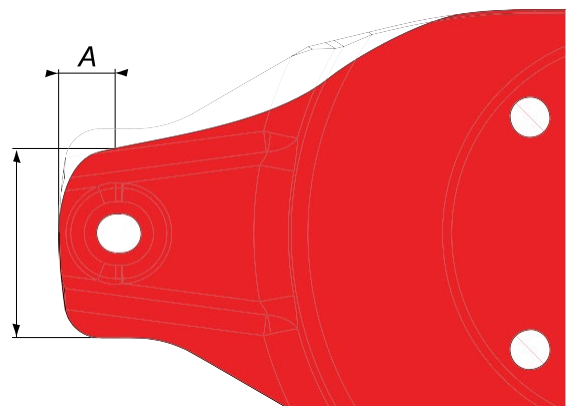

Quick blade replacement

Before carrying out any work on the header, switch the forage harvester motor OFF, remove the ignition key, wait until all rotating parts have come to a complete standstill and apply the parking brake.

Worn or deformed blades must be replaced immediately.

Under no circumstances whatsoever must blades be straightened.

Always replace both cutter disc blades at the same time.



Removing the blade

Clean the top surface of the protective runner

Clean the cavities between the cutter disc and spring plate

Remove harvest residue from between the blade and the bolt by hitting it lightly with a wooden mallet.

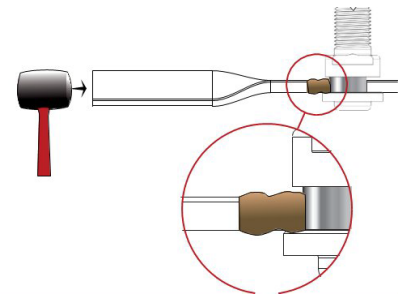

Insert the full length of the special tool between the cutter disc and the spring plate.

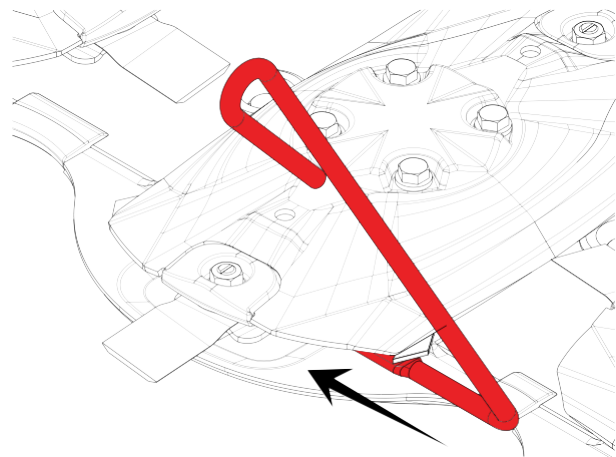

Quick blade replacement

Turn the special tool from top to bottom to lift the spring plate off the head of the bolt.

Check that the bolt and nut are in perfect condition and replace if necessary.

Tightening torque: 12 daNm (89 lbfft)

Blunt blades increase the power requirement and decrease the cutting quality.

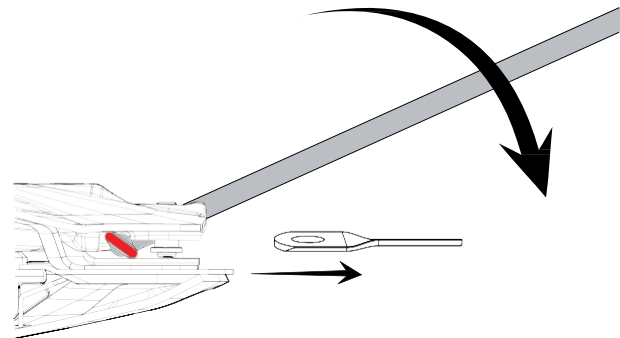

Fitting

Blunt blades can be replaced or turned over and be fastened to the same disc, so that mowing is done by the blade's second cutting edge. An arrow on the blade indicates the direction of rotation of the cutter disc.

Anti-clockwise rotating cutter disc blade

Clockwise rotating cutter disc blade

The article number and dimensions of the blades can be found on the tickers on the header.

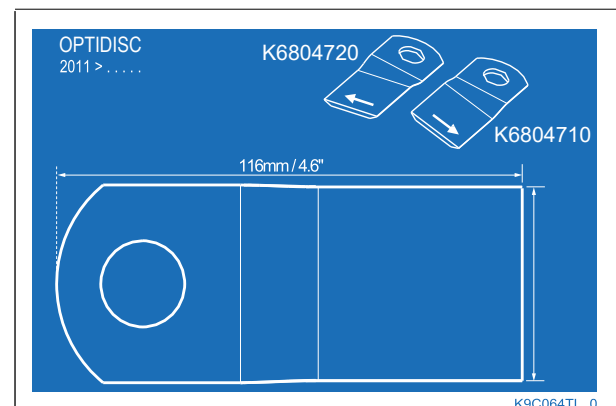

Turn the special tool from top to bottom to lift the spring plate off the head of the bolt.

Insert the new blade into the head of the bolt.

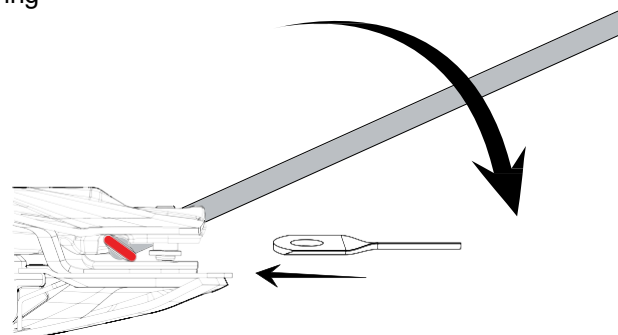

Quick blade replacement

Push the blade upwards and pull it outwards before releasing the special tool.

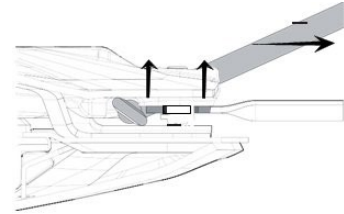

Check that the blade is completely locked and that it can turn freely in the bolt head.

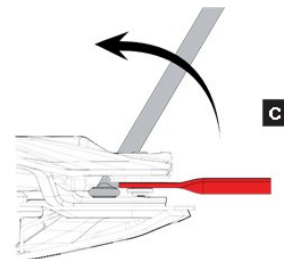

Check that the head of the bolt slides freely into the hole in the spring plate.

Remove the special tool.

Rotate the cutter disc by half a turn.

Repeat the procedure described above.

Carry out the same work on the other cutter discs.

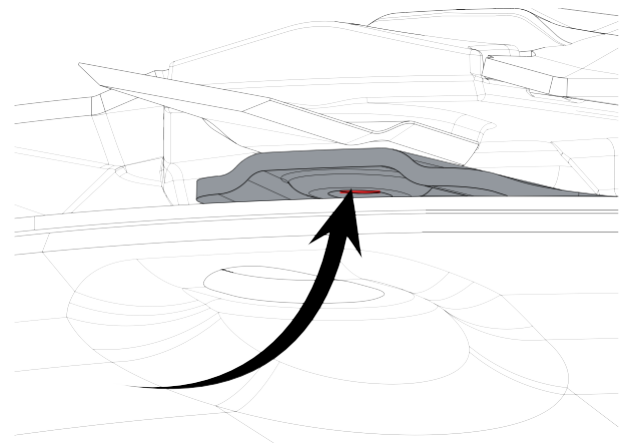

When the last blade has been replaced, check that the special tool has been removed and stowed in its holder.

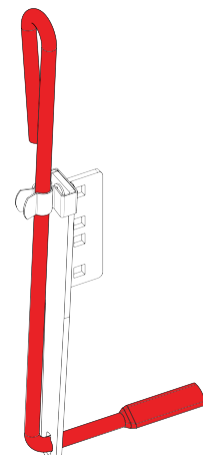

Disc replacement

Only use discs with a dirt stripper.

The drive cutter discs must only be replaced by an authorised dealer.

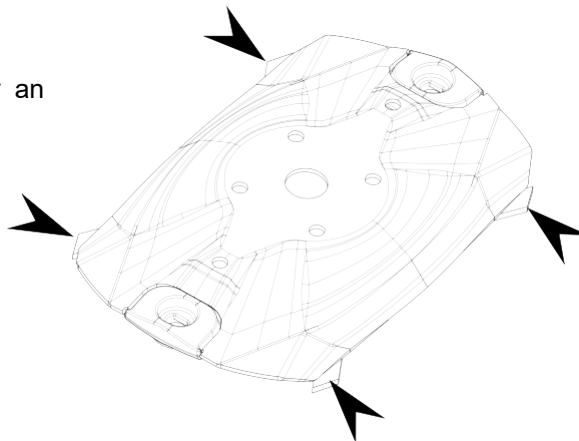

Removing central discs

Insert a block of wood (1) between the two cutter discs to prevent them from turning.

Remove the bolts (2) including the curved spring washers.

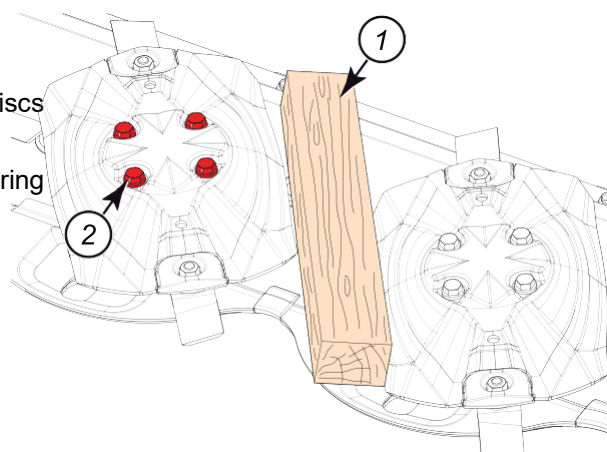

Remove the cutter disc cover (1).

Remove the cutter disc (2).

Replace worn or damaged cutter discs for new cutter discs.

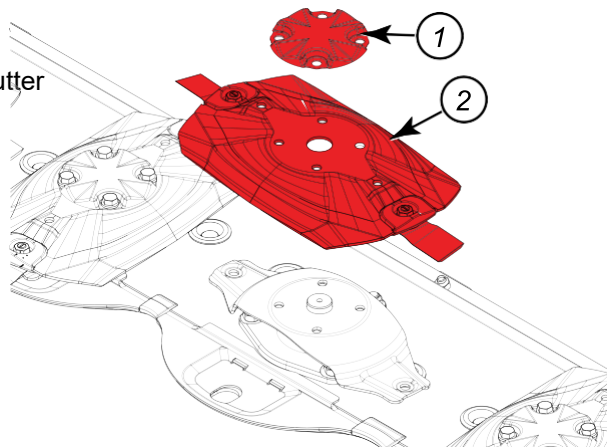

Disc replacement

Replacement

Replace the disc (2),

Observe the direction of rotation of the discs dependent upon how the blades are fitted. Check that the arrow on the blade points in the direction of rotation of the disc.

Replace the disc cover (1).

The angle between neighbouring discs must be 90° .

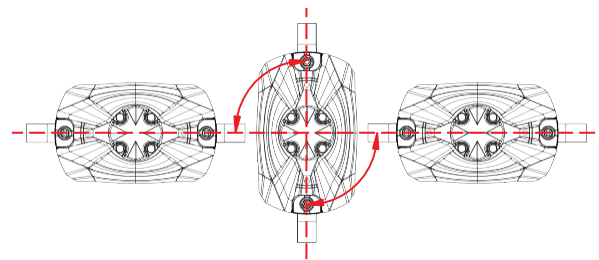

Replace the bolts (1) including the curved spring washers.

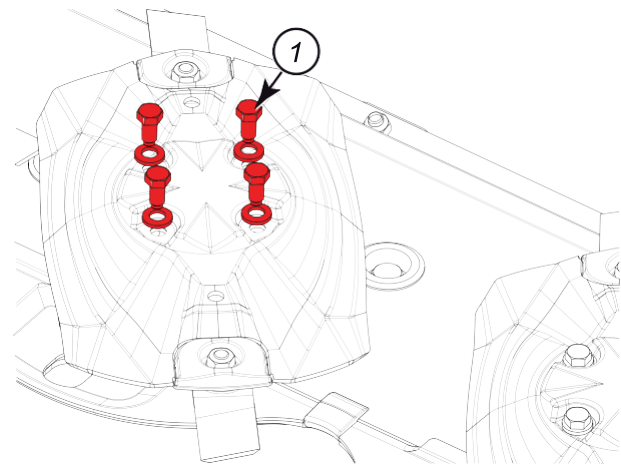

Align the curved spring washers with the curved side up.

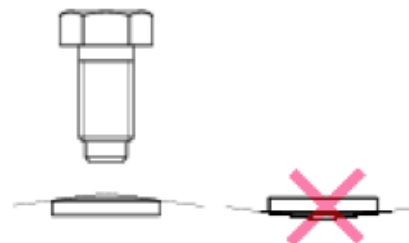

Disc replacement

Place a wooden block (1) between the two cutter discs.

Tighten the bolts (2).

Tightening torque 12 daNm (89 lbfft)

Remove the wooden block.

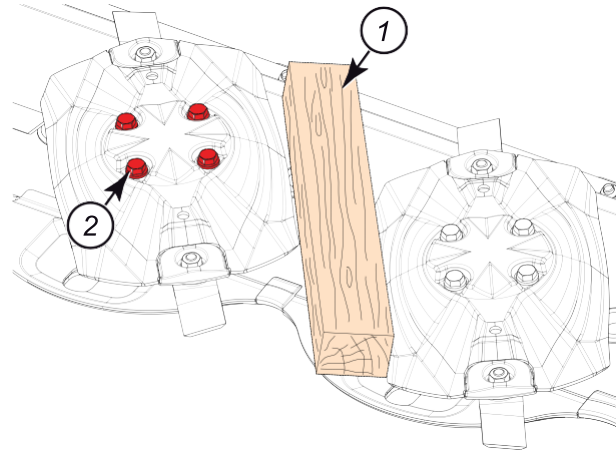

Check that there is a gap of at least $X = 1$ mm between the spring plate and the cutter bar runners.

If not, fit one or a maximum of two spacers between the cutter bar bearing module and the spring plate.

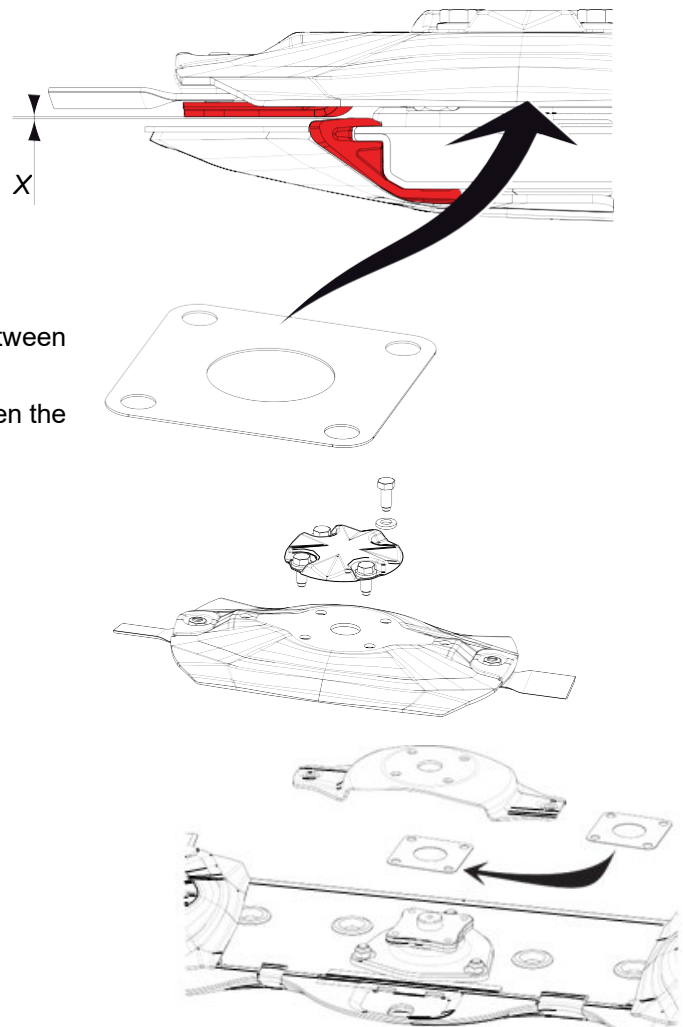

Disc replacement

Spring plate replacement

Drive disc:



The spring plate on the inner cutter disc must only be replaced by an authorised dealer.

Central discs:



Refer to previous pages for disc replacement.

Remove the disc and remove the spring plate (1).
Replace the disc.

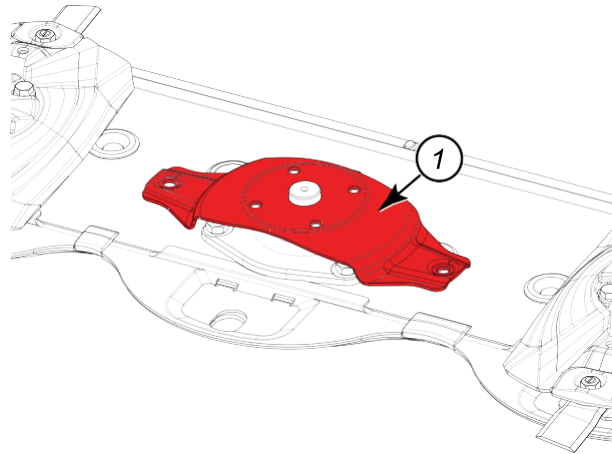

Chain lubrication

Mode of operation

The drive is rotated by a flexible shaft directly from the three-speed gearbox. This drives the pump shaft centrally mounted in the pump body and the cam disc into a rotating movement via a gear unit. This results in the stroke movement of the delivery pistons. In the pump body there are a maximum of six delivery pistons arranged in a circle. Control is effected by the rotary movement of the pump shaft via a suction and pressure channel. On the suction stroke, during which the pressure channel is closed, the delivery piston sucks oil in from a tank on the machine. When the suction stroke has been completed, the pump shaft closes the suction channel by the above mentioned rotary movement and opens the pressure channel so that the oil can be fed under pressure to the lubrication point by the stroke movement of the delivery piston that follows.

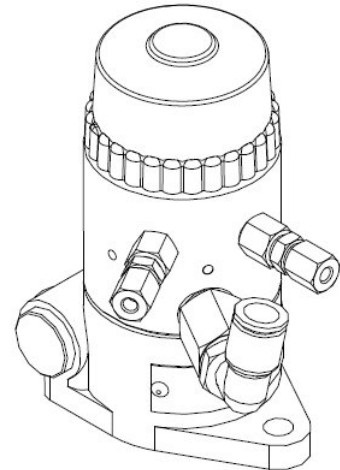

Technical data

Capacity:
max. 0.06 cm³ per stroke and exit

Viscosity range:
25–1500 mm²/s

Temperature range:
Medium 0–70 °C
Environment 0–40 °C

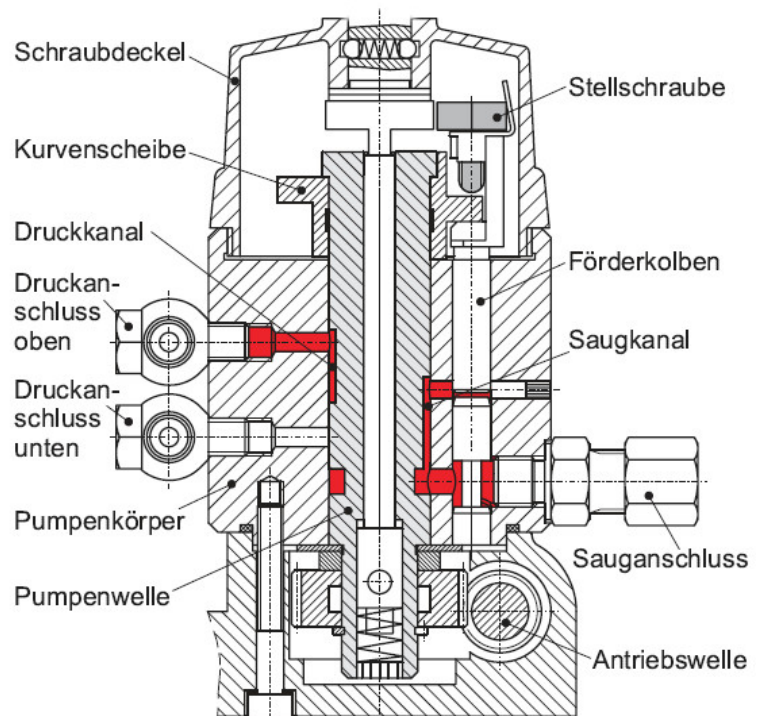

Chain lubrication

Setting delivery volume

To increase piston stroke and therefore the delivery volume, turn the adjusting screw in the delivery piston clockwise; to reduce delivery volume, turn the adjusting screw anticlockwise. To adjust the delivery volume, unscrew the screw cap, set the required delivery volume with the adjusting screw and refit the screw cap.

The delivery volume can be reduced by up to three full revolutions of the adjusting screw without impairing the pump's function.

With each full revolution of the screw, the delivery volume changes by $\frac{1}{4}$ of the total delivery volume.

The pumps are factory-preset to full stroke. The delivery volume should be set only after commissioning and after all air has been bled at the compressed air union.

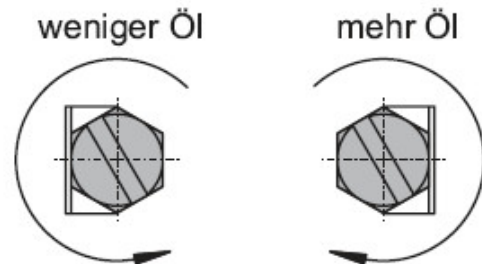

Stellschrauben

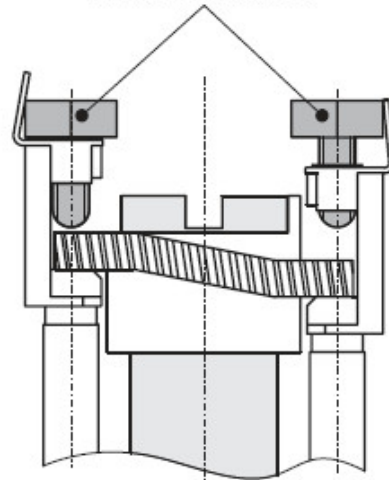

The pump is fitted directly onto the three-speed gearbox on the right-hand side of the header. Behind the connection PTO shaft of the gearbox and the right-hand side wall.



Chain lubrication

Chain lubrication filter

A metal mesh filter is fitted inside the chain lubrication tank.

Size of the mesh 1 mm



Adjust the chain lubrication brush such that it comes lightly into contact with the chain.

To do this, the two M8x25 hexagon headed bolts must be loosened. The brush can then be moved within the elongated holes.



Crop divider

Both crop dividers are each equipped with a wearing tip (A) that is fastened by screws. This can be replaced quickly as necessary.

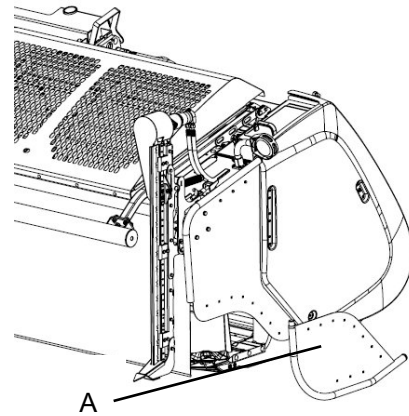

The cutter bar shear bar is located on the inside of the wearing tip. This prevents striations forming on the outside of the header. This can be adjusted in height via the three mushroom headed bolts.

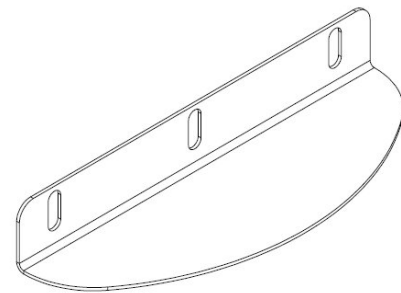

When replacing the shear bar, pay attention to the correct position. If this is not adjusted correctly, damage can be caused to the cutter blades.

Side Knife

Attachment of side knives

Side knives can be fitted to both sides of the header as an optional extra.

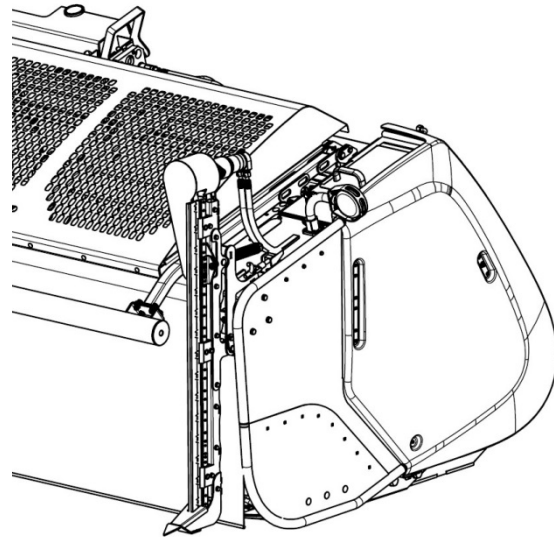

Unscrew the extension piece from both sides of the adjusting bar. Use the existing hole (A) in the extension piece to do this.

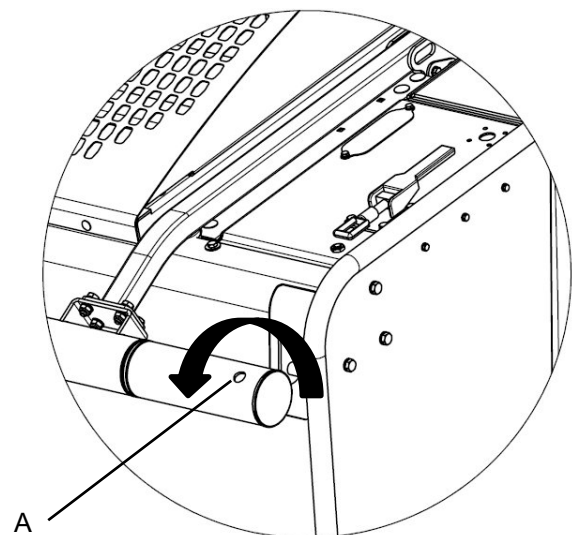

Unlatch the flap covering the hydraulic connections by pulling the unlatching knob (A) and pull it upwards by the grip until the latching pin engages in the hole foreseen for this purpose.



Side Knife

Unscrew the dust caps from the hydraulic connections.



Hook the side knife onto the respective side by hooking the mounting hook (A) into the shaft pieces foreseen for this purpose. The positions of the mounting points are each cut out of the protective apron. Make sure that the hydraulic motor on each side knife faces towards the centre of the header. The hook (B) is the opposite part of the eccentric clamp, to secure the side cutter in position. The tension of the clamp can be increased by the rubber buffer (C).

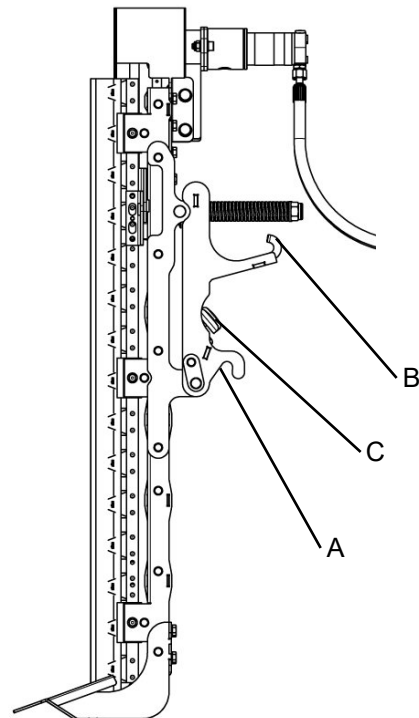

Side Knife

Pivot the side knife upwards, over the hook mounting and secure it by means of the eccentric clamp (A). Screw the hydraulic connections in. The position of the hoses is independent from their direction of rotation of the hydraulic motors.

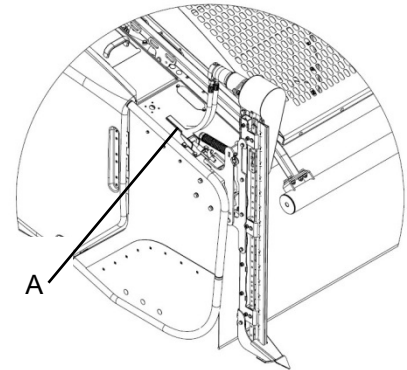

On the side knife mounting of the type 660 header trailer there is a parking position (B) for the adjustment bar extensions. These must be stowed there when not in use.

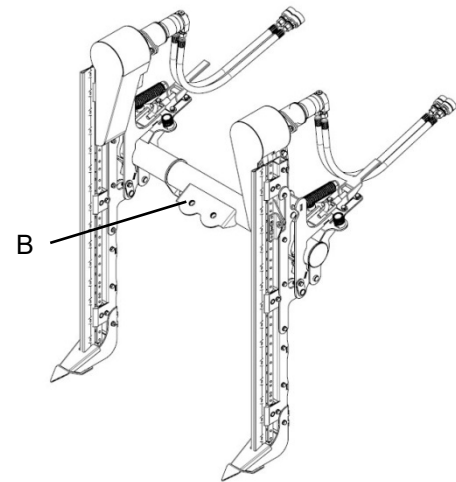

A collision protection safeguards the side cutter against excessive loads. The spring tension (A) should be checked as required. This can be adjusted via the M20 securing nut.

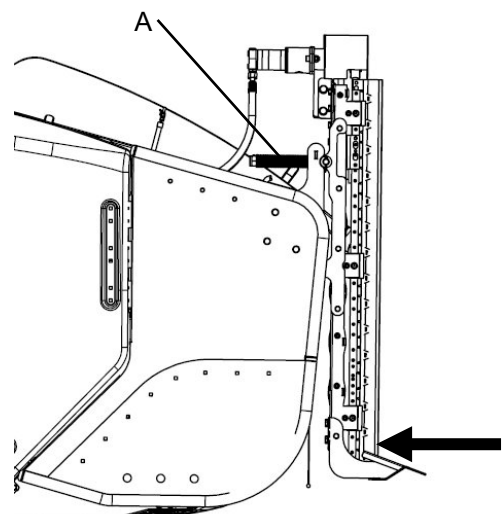

Side Knives

Integrated hydraulic drive

Optionally, the cutting unit can be equipped with a hydraulic drive for driving the side knives. This drive is located on the right side, inside the side wall.

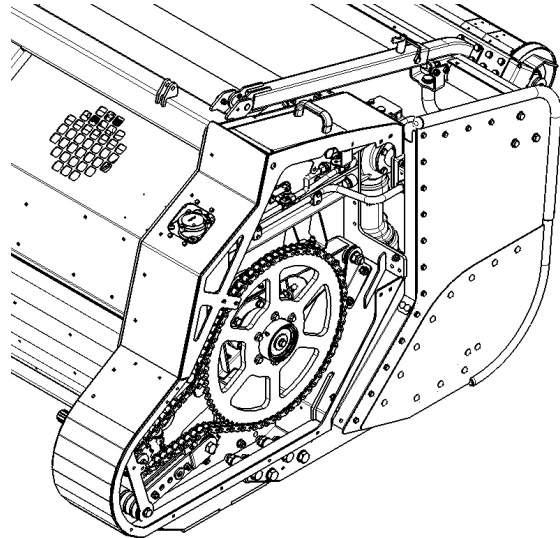

All components of the drive can be found behind the right side door in the cutting unit. The oil level is controlled by the level indicator in the tank.

Technical data of the drive:

Delivery volume: 22 l/min
Max. Pressure: 140 bar

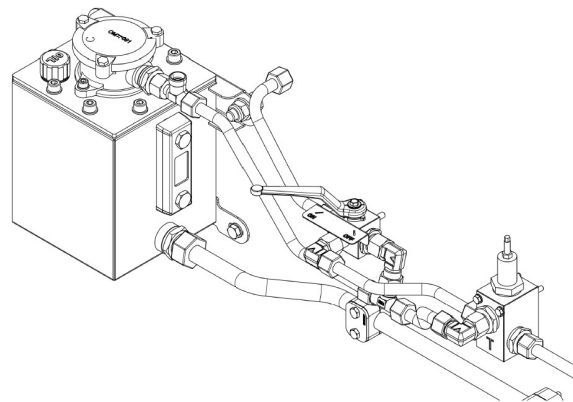

Switching on and off on-board hydraulics

The side knife drive is switched on with the ball valve.

If the side separators are not mounted, it is absolutely necessary to set the lever to the "OFF" position.

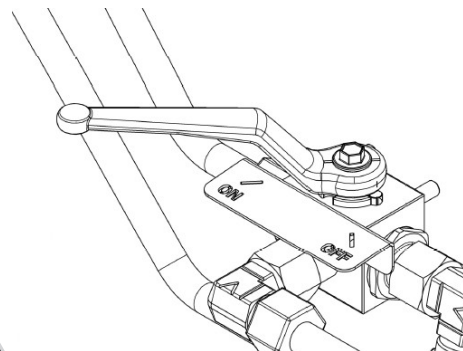

Transportation of the header

Loading onto the SWW 660 Header Trailer

Before loading the header onto the header trailer, the header must be brought to the transportation position. This includes lowering the adjustment bar and removing the side cutters if they are fitted. The header must then be unlatched at the pendulum frame, the drive PTO shaft removed (if no quick-action coupling is fitted) and the multi-connector disconnected (refer to the forage harvester Operating Manual).

It must also be checked that the locking flaps are in the open position.

The type SWW 660 header trailer must be in the lowered position, directly ahead of the header (parallel).

The indicator rod on the header trailer is aimed for with the centre support arm of the adjustment bar. The two locating pins of the Profi Cut can be seen at the right and left of the header. When the receiving blocks have been reached, lower the header onto them. Make sure that the two pins lie in the supports for them. Do not uncouple the header as described in the Operating Manual.

Lock the header in position by operating the locking bolts (A) in the transportation position. Do this by bringing the locking flap to the closed position by means of lever (B). Carry out this procedure at both locking points. After locking the cutter bar, also check the two hooks (C) on the back of the header to ensure that they clasp the support pins.

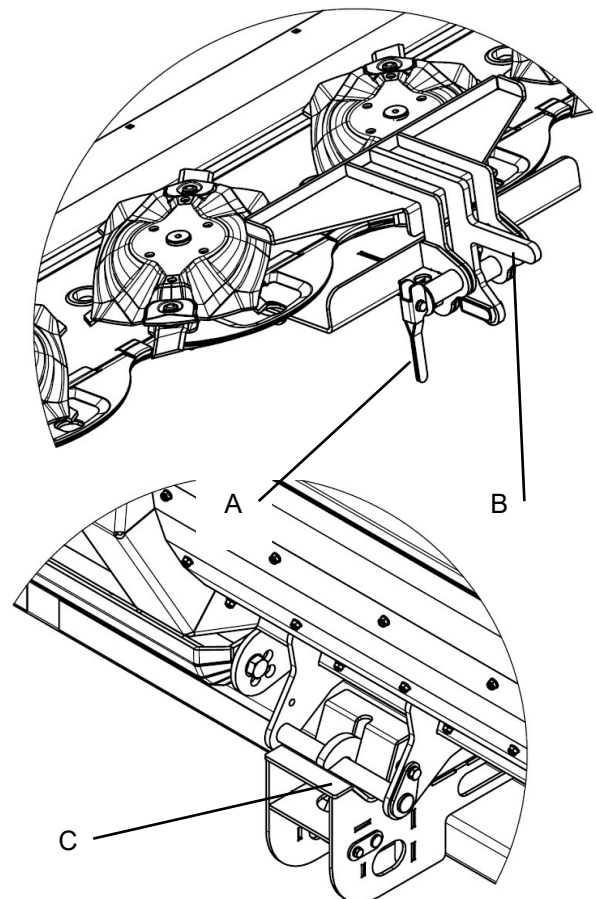

Check that the header is locked to the header trailer in order to prevent transportation damage.

Raise the header trailer to the transportation position.



Maintenance

Side angle gearbox

Run the machine for a few minutes before changing the oil, so that the oil is warm.

The gearbox is filled with 1.1 ltr of Shell Omala S4GX 220 grade API GL5 (EP = extreme pressure) transmission oil.

When changing the oil, it is recommended to use a type PAO synthetic oil.

Remove cover (A) in the side cladding by removing the bolts (M6x15). Remove the dipstick by unscrewing it.

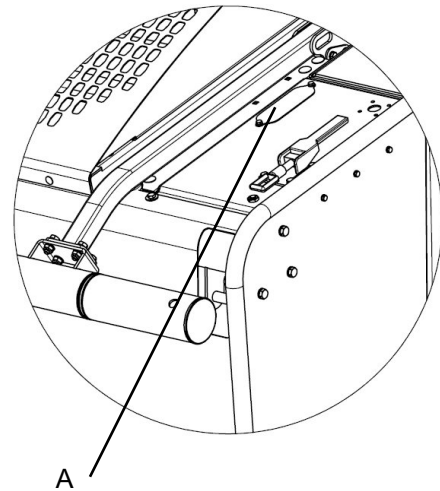

Position a suitable container underneath the oil drain plug. Remove the oil drain plug. Allow the oil to drain into the collection container. Wait until the old oil has drained completely. Clean the oil drain plug and screw it back in. Replace it if necessary. Re-fill with oil of the specified quantity and quality through the filler opening.

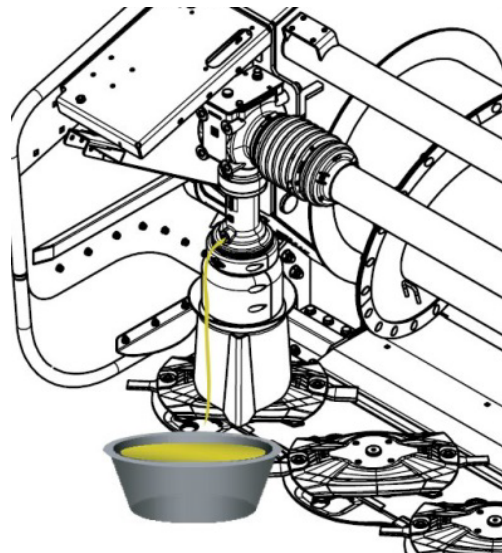

Gearbox oil level check:

The maximum oil level corresponds with marking (A) on the dipstick.

The minimum oil level corresponds with marking (B) on the dipstick.

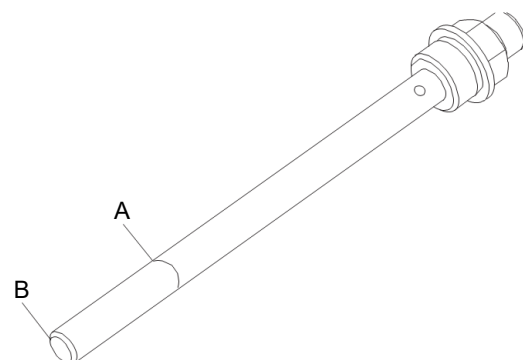

Maintenance

Cutter bar

Both cutter bars are greased for life and do not require further periodic maintenance.

If the oil level can not be determined precisely, drain the oil off and re-fill with fresh oil of the specified amount and quality.

After any interventions on the cutter bar or if an oil leakage occurs, an oil change must be carried out on the cutter bar.

Draining the oil

Run the machine for a few minutes before changing the oil, so that the oil is warm.

The cutter bar is filled with transmission oil of ASX 75W90 viscosity and API grade GL5 (EP = extreme pressure).

Profi Cut 530 3 ltr per cutter bar

Profi Cut 700 4 ltr per cutter bar

To do this, a runner (1) must be removed from the bar in each case.

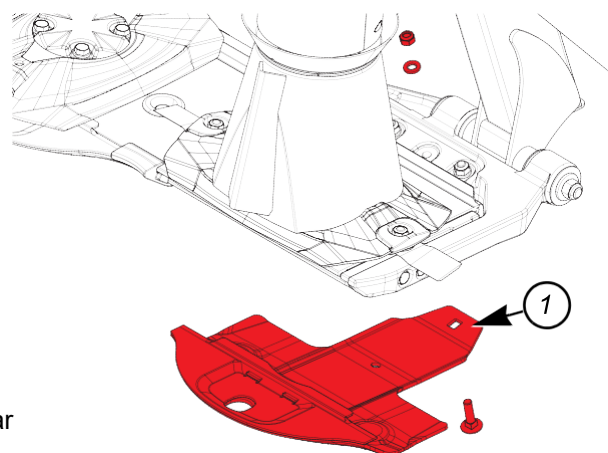

Position a suitable container underneath the oil drain plug. Raise the opposite side of the header to the oil drain plug a little. Unscrew and remove the oil drain plug (1) together with the seal. Wait until the oil has drained completely. Clean the oil drain plug and screw it back in together with the seal. Replace the seal if necessary. Re-fill with oil of the quantity and quality specified by the manufacturer. Replace the runners.

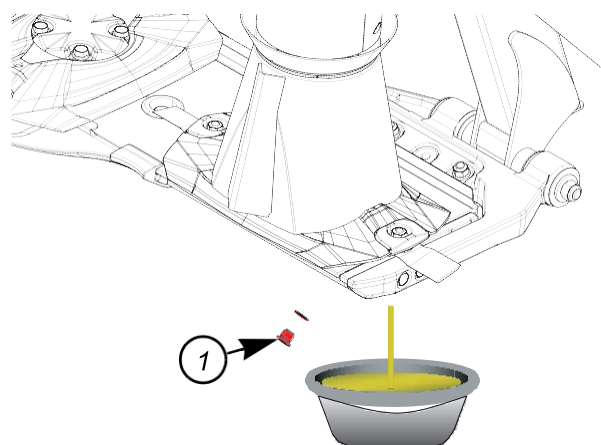

Maintenance

Stop the motor before lubricating the universal drive shafts. Clean all grease nipples before lubricating.

If used intensively, it is recommended to shorten the lubricating intervals.

All PTO shafts after 50h:

The joints of the PTO shafts (1)

The profiled tube of the PTO shafts (2)

The bearing rings of the PTO shaft (3)

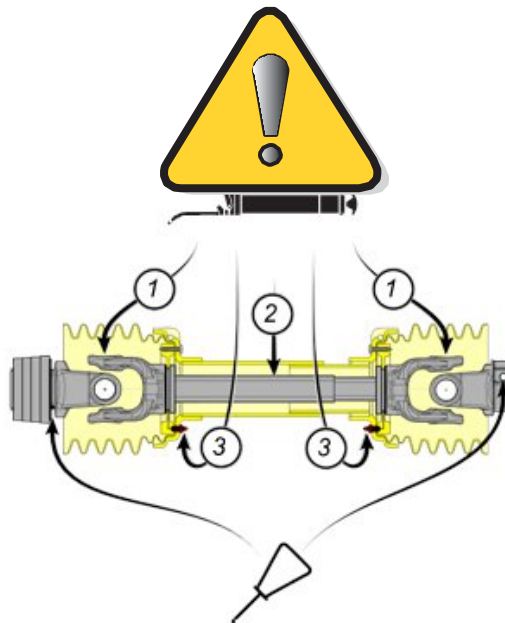

With the cutter bar drive shaft, lubricate the free-wheel under the PTO protection every 50 h imperatively.

Maintenance every 50h or as required:

Lubricate all other lubrication points.

There are lubrication points on all bearings and ball joints.

The collision protection and drive on the side cutter.

Maintenance every 250h or at the end of the season:

Check the tension of all drive chains.

Check the main drive's belt tension.

Change the oil in the gearboxes.

Position of the lubrication points

All lubrication points are shown here. All bearings that must be lubricated are indicated by red arrows. These include the drive shafts and the intake screw bearings. The protective doors must be opened to lubricate the intake screw bearings. The friction coupling guard must be opened to lubricate the bearings for the belt drive's drive shaft. All PTO shafts that must be lubricated are indicated by blue arrows. The protective covers must be opened to lubricate the two intermediate shafts.

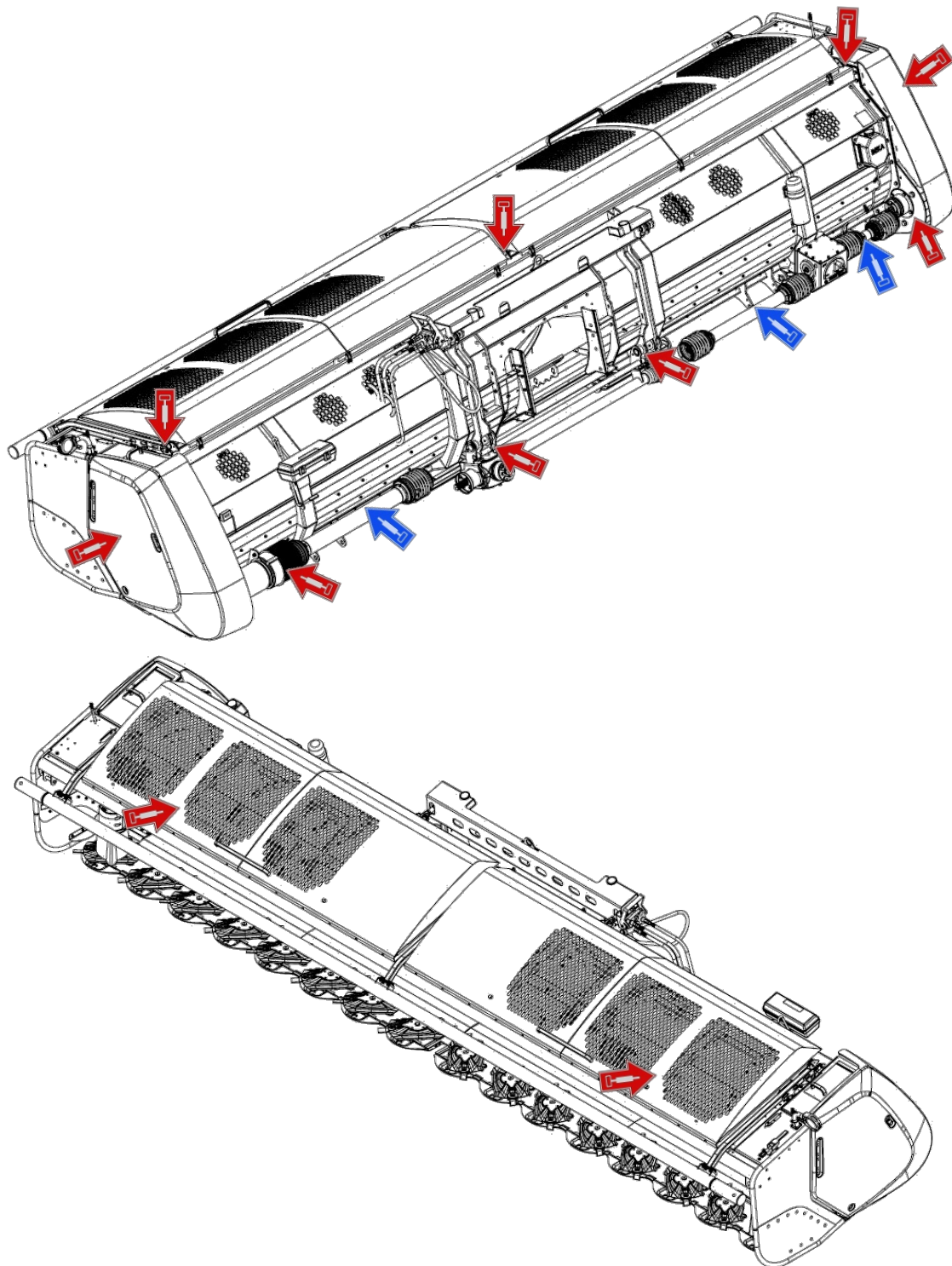

Position of the lubrication points

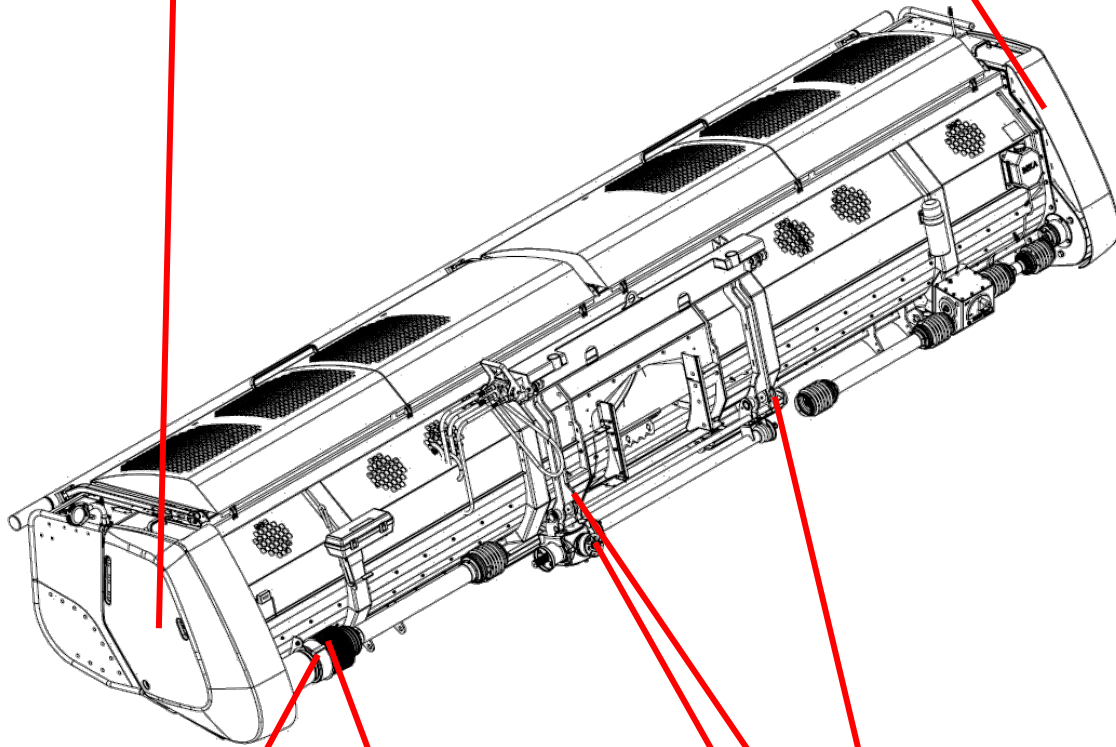
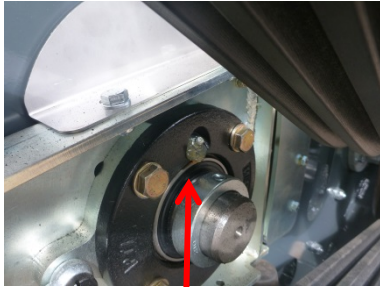

Position of the lubrication points

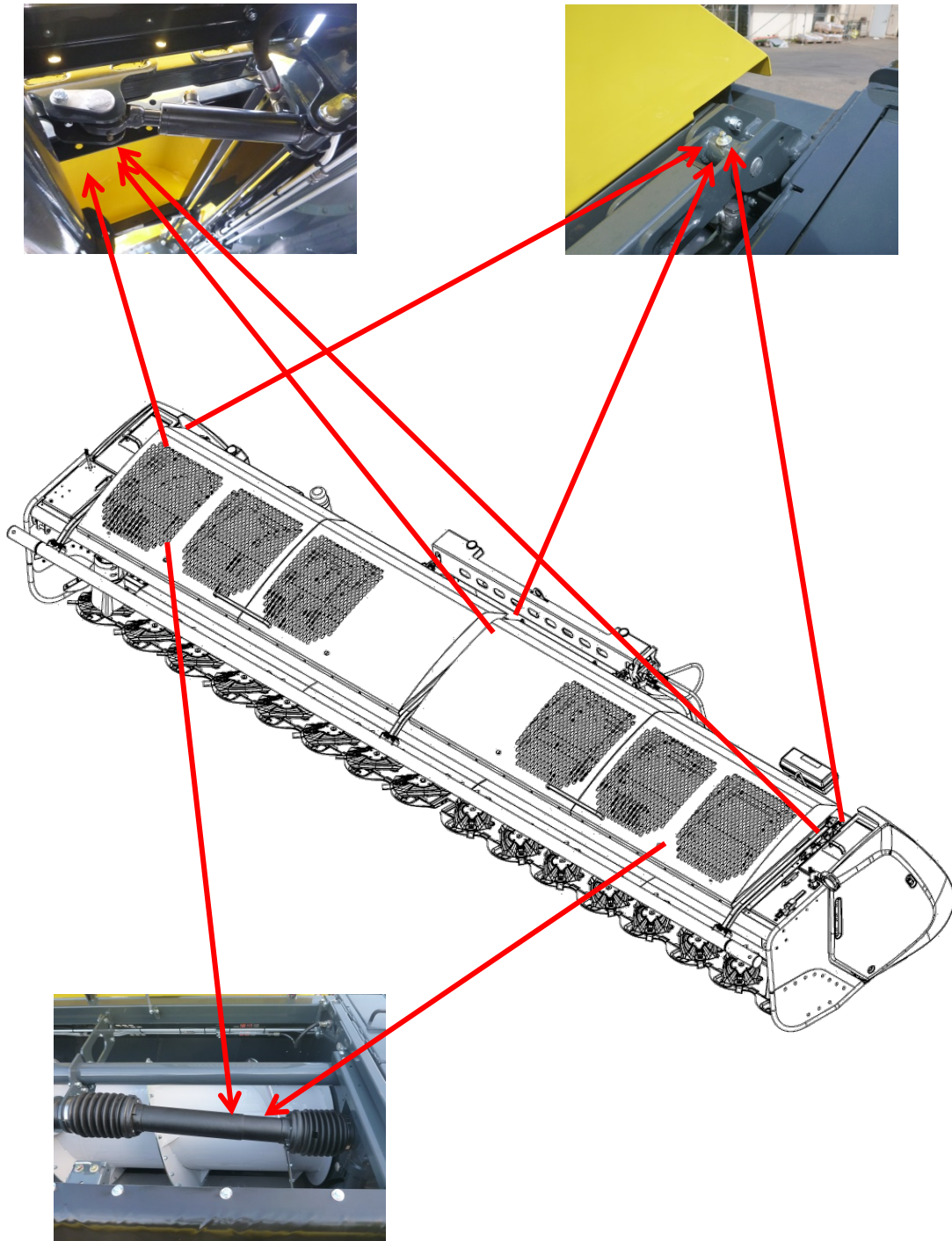

Position of the oil level inspection plugs

The oil level inspection plugs for the two cutter bar gearboxes are located under the covers in the right- and left-hand side parts.



The inspection plug for the main gearbox is on the side. Two size 7 hex socket-head bolts are located here. The bottom bolt is the correct level of fill.



The level indicator for checking the oil level for the hydraulic side knife drive is mounted directly on the hydraulic oil tank. The tank is located behind the right side door. A "Minimum" and "Maximum" label is provided.



Lubricants and oils

Drive gearbox oil

Select an oil viscosity which is appropriate for the outdoor temperatures to be expected until the next oil change.

The following oils should be preferred for use:

Shell Spirax A GETRIEBEÖL (viscosity SAE 75 W 90, grade API GL 5 EP)

Shell Omala S4 GX 220

Other oil types used must conform to API specification GL-5 EP.

Grease

Select grease according to NLGI consistency and the outdoor temperatures expected until the next servicing.

The following grease is recommended:

Shell Alvania Grease RL 2, Gadus S2 V100 2

Other greases can be used if they meet the specifications.

Important:

Replace missing grease nipples immediately. Clean grease nipples thoroughly before lubricating.

Chain lubrication

The following oil is recommended:

Shell Naturelle HF-E 46

You can also use oils of viscosity class (at 40 °C) = 40–300 mm²/s.

Faults and troubleshooting

Fault	Cause	Remedial action
Unsatisfactory cut quality	Blunt or deformed blades	Replace the blades.
	Blades fitted incorrectly	Check that all arrows on the blades point in the direction of rotation.
	Input speed is too low	Check that the header speed is set to 750 revs/min.
Accumulation of earth on the front of the cutter bar	Insufficient cutter bar or header load relief	Adjust the contact pressure of the header.
	Extremely wet operating conditions	
Bad terrain adaptation	Driving speed too high	Reduce driving speed.
	Contact pressure set too high	Decrease the contact pressure.
Intake screw clogs up (back feeding)	Cutting length set to very short	Match the driving speed to suit the conditions (reduce).
	Paddles on the intake screw too aggressive	Turn the paddles from the toothed position to the non-toothed position.
Header hits the ground very quickly	Lowering speed set incorrectly	Adjust the lowering speed.
Belt drive slips	Insufficient tension	Check drive belt tension.
	Cutter bar seized	Check whether foreign objects in the area of the cutter bar are causing the fault.
Side knife does not work	Auxiliary drive release not active (John Deere only)	Sensor in cutting unit defective Replace sensor
		Sensor did not switch Check reacting distance
	Side knife not switched on (hydraulic side knife drive)	Three-way valve did not switch correctly Check switch position
	Coupler of the side knife is loose	

Technical data

	Profi Cut 530	Profi Cut 700
Overall width	5360 mm	7060 mm
Working width	5300 mm	7000 mm
Overall depth	2010 mm	2010 mm
Overall height	1410 mm	1410 mm
Total weight	2960 kg	3250 kg
Number of cutter discs per bar	6	8
Total number of cutter discs	12	16
Angled gearbox transmission ratio	1:3,1	1:3,1
Input speed at knife bar	max. 3000 rpm	max. 3000 rpm
Input speed of header	max. 750 rpm	max. 750 rpm
Main friction clutch torque	2400 Nm	2400 Nm
Intake Auger friction coupling torque	2700 Nm	3300 Nm

Technical data

	Profi Cut 530	Profi Cut 700
Fill level, 3-speed manual gearbox	3.1 ltr	3.1 ltr
Main gearbox fill level	2.1 ltr	2.1 ltr
Angled gearbox oil capacity	1.1 ltr	1.1 ltr
Cutter bar oil fill level	3.0 ltr	4.0 ltr

General terms of guarantee

Zürn Harvesting GmbH & Co. KG, Kapellenstraße 1, D-74214 Schöntal-Westernhausen (hereinafter “**Zürn Harvesting**”) hereby certifies for each customer who has purchased a new Zürn Harvesting machine from an authorised dealer that the materials and workmanship of this machine are guaranteed under the conditions specified below, providing that the machine is put into operation and maintained in accordance with the specifications in the operating instructions.

I. Duration of the guarantee

The guarantee period is one year from delivery of the machine by Zürn Harvesting and is valid for up to 500 operating hours within this period. The replacement of individual parts or repair will not prolong the above guarantee period for the machine.

II. Scope of the guarantee

The guarantee embraces only the reimbursement or repair of the parts and reimbursement of work time required in order to effect the repair, based on the repair times allowed by Zürn Harvesting, under the prerequisite that the fault was determined by our technical customer service department and was acknowledged by Zürn Harvesting to be attributable to faulty materials or workmanship. Replaced parts will become the property of Zürn Harvesting. The customer must allow services received from the vendor/dealer under warranty to be credited to the guarantee.

The guarantee does not cover any further claims against Zürn Harvesting. This means in particular that travel and transport costs will not be reimbursed, nor will Zürn Harvesting be liable for consequential damage, such as loss of harvest or losses of income.

III. Limitations of the guarantee

The guarantee does not apply to defects or faults that are attributable to:

- usual wear and tear;
- failure to heed operating, storage or transport instructions contained in the operating manual;
- use other than as intended, inadequate maintenance, inexpert operation or excessive use;
- damage caused to the machine or its equipment caused during transportation or loading; machines, equipment and parts are shipped at the risk of the recipient;
- external influences on the machine, e.g. third-party damage, weathering or other natural occurrences;
- circumstances that were known to the buyer at the time of purchase.

The guarantee will be rendered null and void if technical modifications are made to the machine without the written consent of Zürn Harvesting or if spare parts other than original Zürn Harvesting spare parts are installed and/or if repairs were not carried out by an authorised dealer. The guarantee is likewise voided if the machine was not put into service for the first time by the dealer in accordance with the instructions of Zürn Harvesting.

General terms of guarantee

IV. Assertion of the guarantee

The terms of the guarantee are dependent upon precise observance of the following regulations by both the dealer and the purchaser:

- The guarantee card (machine card) completed by the dealer and customer must be returned to Zürn Harvesting by post or e-mail as soon as the machine has been delivered to the customer.
- Applications for guarantee claims must be formulated on the corresponding Zürn Harvesting form and presented to Zürn Harvesting by the dealer within one calendar month of discovery of the defect/fault.
- The application must be completed legibly and must contain the following information:
 - Name, address and dealer customer number
 - Name and address of the purchaser
 - Exact machine type and designation
 - Complete serial number of the machine
 - Date of delivery to the dealer and to the purchaser
 - Date of the claim
 - Number of operating hours or acreage harvested by the machine
 - Exact description of the damage and information regarding the probable cause
 - Quantity, item numbers and description of damaged parts

The parts reported as damaged must be returned to Zürn Harvesting free of charge for appraisal, complete with a copy of the guarantee claim application. Any costs incurred for returning the parts replaced or repaired will be borne by the sender.

If the guarantee claim application is refused, the dealer or the customer has a period of 15 days, starting from the day the Zürn Harvesting decision was received, to demand return of the damaged parts. Once this period has elapsed, the parts will be disposed of.

V. Additional clauses

Claims under the guarantee may not be transferred to third parties without the prior, written consent of Zürn Harvesting.

The dealer has neither the right nor the authority to make declarations or to enter into a commitment etc., whether express or implied, in the name of Zürn Harvesting.

The technical support for repair of the machine given by Zürn Harvesting or their representatives excludes any further liability whatsoever by Zürn Harvesting and has no influence whatsoever on the existing terms of guarantee.

Zürn Harvesting reserves the right to modify the design of the machine without prior notice. It is not obliged to transfer such modifications to machines which have already been sold or are in use.

Furthermore, due to the rapid development of the state of the art, no guarantee can be given for the machine descriptions contained in these operating instructions or other technical leaflets and data sheets.

Torques for metric bolts

Bolts	Grade 4.8				Grade 8.8 or 9.8				Grade 10.9				Grade 12.9			
	Oiled ^a		Dry ^b		Oiled		Dry ^b		Oiled		Dry ^b		Oiled		Dry ^b	
Size	N•m	lb-in	N•m	lb-in	N•m	lb-in	N•m	lb-in	N•m	lb-in	N•m	lb-in	N•m	lb-in	N•m	lb-in
M6	4.7	42	6	53	8.9	79	11.3	100	13	115	16.5	146	15.5	137	19.5	172
									N•m	lb-ft	N•m	lb-ft	N•m	lb-ft	N•m	lb-ft
M8	11.5	102	14.5	128	22	194	27.5	243	32	23.5	40	29.5	37	27.5	47	35
			N•m	lb-ft	N•m	lb-ft	N•m	lb-ft								
M10	23	204	29	21	43	32	55	40	63	46	80	59	75	55	95	70
	N•m	lb-ft														
M12	40	29.5	50	37	75	55	95	70	110	80	140	105	130	95	165	120
M14	63	46	80	59	120	88	150	110	175	130	220	165	205	150	260	190
M16	100	74	125	92	190	140	240	175	275	200	350	255	320	235	400	300
M18	135	100	170	125	265	195	330	245	375	275	475	350	440	325	560	410
M20	190	140	245	180	375	275	475	350	530	390	675	500	625	460	790	580
M22	265	195	330	245	510	375	650	480	725	535	920	680	850	625	1080	800
M24	330	245	425	315	650	80	820	600	920	680	1150	850	1080	800	1350	1000
M27	490	360	625	460	950	700	1200	885	1350	1000	1700	1250	1580	1160	2000	1475
M30	660	490	850	625	1290	950	1630	1200	1850	1350	2300	1700	2140	1580	2700	2000
M33	900	665	1150	850	1750	1300	2200	1625	2500	1850	3150	2325	2900	2150	3700	2730
M36	1150	850	1450	1075	2250	1650	2850	2100	3200	2350	4050	3000	3750	2770	4750	3500

The tightening torques given are guideline values. Do NOT use these values if a different torque or another securing method is specified for a specific application. For stainless steel bolts and nuts for stirrup bolts, see specific instructions. Tighten locking nuts with plastic insert or edge-raised steel locking nuts to the corresponding torque for dry bolts and nuts given in the table unless otherwise instructed.

Shear pins are designed to break at a certain load. When replacing shear pins, use only pins of the same grade. When replacing bolts and nuts, make sure that equivalent parts of the same or a higher grade are used. Tighten higher-grade nuts and bolts to the same torque as the originally used parts. Make sure that the thread is clean and the bolts correctly fitted. If possible, oil normal and galvanised nuts and bolts (except for locking nuts and wheel studs or nuts) unless specified otherwise for the specific application.

“Oiled” means that a lubricant, such as engine oil, is applied to the bolts or that phosphatized or oiled bolts with a size from M20 are used.

“Dry” means the use of normal or galvanised bolts without lubrication or bolts with a size between M6 and M18 that are zinc-coated.

Certificate of Conformity

**EG- Konformitätserklärung nach Maschinenrichtlinie
2006/42/EG**

Bitte sorgfältig aufbewahren, jedoch nicht im Fahrzeug

**EU CERTIFICATE OF CONFORMITY
According to Machinery Directive 2006/42/EG**

Please keep safely, not inside the vehicle

Hiermit bestätigt die Hereby declares	Zürn Harvesting GmbH & Co. KG	
in alleiniger Verantwortung dass das landwirtschaftliche Anbaugerät the full responsibility for the agricultural implement	Fabrikmarke Brand	Zürn Harvesting
	Typ Type	Profi Cut 530
genehmigt in approved in	Schoental	
am on	19.01.2017	
durch den by the	Hersteller / manufacturer	
den grundlegenden Sicherheits- und Gesundheitsanforderungen der Richtlinie 2006/42/EG entspricht. to full fill the complete safety- and health requirements according to machinery directive 2006/42/EG.		
Zur sachgerechten Umsetzung der in den EU- Richtlinien genannten Sicherheits- und Gesundheitsanforderungen wurden folgende Normen herangezogen: For proper implementation according to the EU- Directives for health and safety requirements, the following standards were used:	DIN EN ISO 4254-1 (06/06) DIN EN 745 (08/99)	
Geschehen zu Done at	Schoental	
am on	05/03/17	
	 Rolf Zürn Harvesting Harvesting, Geschäftsführer, CEO	



Certificate of Conformity

EG- Konformitätserklärung nach Maschinenrichtlinie 2006/42/EG

Bitte sorgfältig aufbewahren, jedoch nicht im Fahrzeug

EU CERTIFICATE OF CONFORMITY According to Machinery Directive 2006/42/EG

Please keep safely, not inside the vehicle

Hiermit bestätigt die Hereby declares	Zürn Harvesting GmbH & Co. KG	
in alleiniger Verantwortung dass das landwirtschaftliche Anbaugerät	Fabrikmarke Brand	Zürn Harvesting
the full responsibility for the agricultural implement	Typ Type	Profi Cut 700
genehmigt in approved in	Schoental	
am on	19.01.2017	
durch den by the	Hersteller / manufacturer	
den grundlegenden Sicherheits- und Gesundheitsanforderungen der Richtlinie 2006/42/EG entspricht. to full fill the complete safety- and health requirements according to machinery directive 2006/42/EG.		
Zur sachgerechten Umsetzung der in den EU- Richtlinien genannten Sicherheits- und Gesundheitsanforderungen wurden folgende Normen herangezogen: For proper implementation according to the EU- Directives for health and safety requirements, the following standards were used:	DIN EN ISO 4254-1 (06/06) DIN EN 745 (08/99)	
Geschehen zu Done at	Schoental	
am on	05/03/17	
	 Rolf Zürn Harvesting Harvesting, Geschäftsführer, CEO	

Contact

Spare parts order

Phone: 0049 (0) 7943 / 9105-42

Fax: 0049 (0) 7943 / 9105-33

E-Mail: parts@zuern.de

Zürn Harvesting GmbH & Co. KG
Eichenstraße 27
D-74747 Ravenstein-Merchingen

Tel.: +49 6297 92885-0
Fax: +49 6297 92885-19
E-Mail: info@zuern.de

Internet: www.zuern.de